



# THERMAL DEFORMATIONS AND STRESSES

## Introduction

It is well known that changes in temperature cause dimensional changes in a body: An increase in temperature results in expansion, whereas a temperature decrease produces contraction. This deformation is isotropic (the same in every direction) and proportional to the temperature change. The strain caused by temperature change ( $^{\circ}\text{C}$ ) is denoted by  $\alpha$  and is called the coefficient of thermal expansion. Thermal strain caused by a uniform increase in temperature  $\Delta T$  is

$$\varepsilon_{th} = \alpha \Delta T$$

and

$$\delta_{th} = \alpha (\Delta T) L$$

### Example 1:

A steel rod of length  $L$  and uniform cross sectional area  $A$  is secured between two walls, as shown in the figure. Use  $L=1.5\text{m}$ ,  $E=200\text{ GPa}$ ,  $\alpha = 11.7 \times 10^{-6} /^{\circ}\text{C}$  and  $\Delta T = 80^{\circ}\text{C}$ . Calculate the stress for a temperature increase of  $\Delta T$  for:

- The walls are fixed.
- The walls move apart a distance 0.5mm.

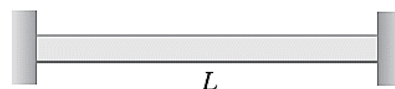



**Solution:**

$$a) \delta_{th} - \delta_R = 0$$

$$\alpha(\Delta T)L - \frac{RL}{AE} = 0$$

$$\therefore R = A E \alpha (\Delta T)$$

$$\sigma = \frac{R}{A} = E \alpha (\Delta T)$$

$$= 200 \times 10^9 \times 11.7 \times 10^{-6} \times 80 = 187.2 \text{ MPa (Answer)}$$

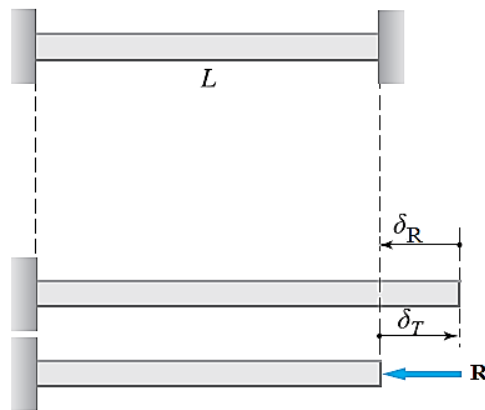

$$b) \delta_{th} - \delta_R = \delta_w$$

$$\alpha(\Delta T)L - \frac{RL}{AE} = \delta_w$$

$$R = AE \left( \alpha \Delta T - \frac{\delta_w}{L} \right)$$

The compressive stress is then,

$$\sigma = \frac{R}{A} = E \left( \alpha \Delta T - \frac{\delta_w}{L} \right)$$

$$= 200 \times 10^9 \left( 11.7 \times 10^{-6} \times 80 - \frac{0.5 \times 10^{-3}}{1.5} \right) = 120.52 \text{ MPa (Answer)}$$

**Example 2:**

A rigid block having a mass 5 Mg is supported by three rods symmetrically placed, as shown in the figure. Determine the stress in each rod after a temperature rise of 40 °C. Use  $E_s=200 \text{ GPa}$ ,  $\alpha_s=11.7 \mu\text{m/m}\cdot^\circ\text{C}$ ,  $A_s=500 \text{ mm}^2$ ,  $E_b=83 \text{ GPa}$ ,  $\alpha_b=18.9 \mu\text{m/m}\cdot^\circ\text{C}$ , and  $A_b=900 \text{ mm}^2$ .

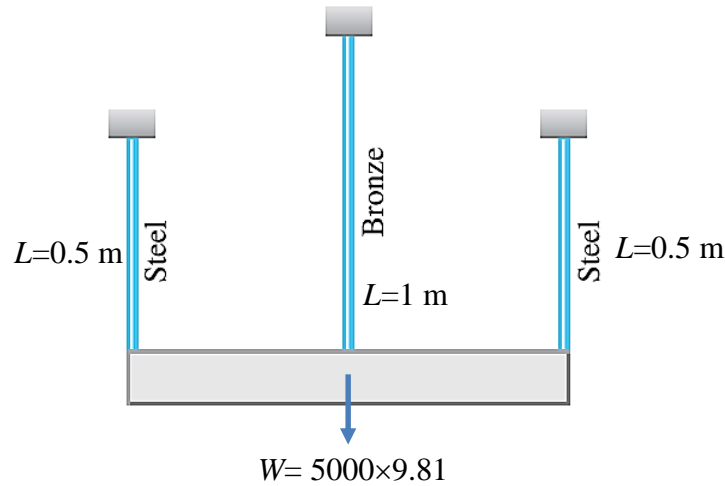

**Solution:**

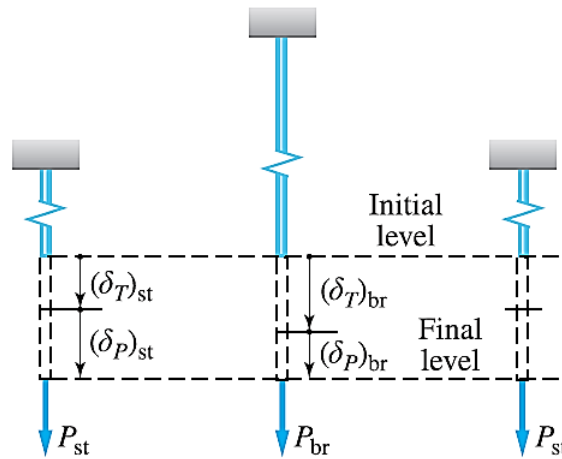

Deformation

$$\delta_{th_s} + \delta_{P_s} = \delta_{th_b} + \delta_{P_b}$$

$$\alpha_s(\Delta T)L_s + \frac{P_{st}L_s}{A_sE_s} = \alpha_b(\Delta T)L_b + \frac{P_{br}L_b}{A_bE_b}$$

$$11.7 \times 10^{-6} \times 40 \times 0.5 + \frac{P_{st} \times 0.5}{500 \times 10^{-6} \times 200 \times 10^9} = 18.9 \times 10^{-6} \times 40 \times 1 + \frac{P_{br} \times 1}{900 \times 10^{-6} \times 83 \times 10^9}$$

Simplifying the above equation,

$$P_{st} - 2.6P_{br} = 104 \times 10^3 \text{ N} \tag{1}$$

Statics (Free Body Diagram, F.B.D)

$$2P_{st} + P_{br} = 5000 \times 9.81 = 49.05 \times 10^3 \text{ N} \tag{2}$$



Solving equation (1) and (2),

$$P_{st} = 37.0 \text{ kN} \text{ and } P_{br} = -25 \text{ kN (compression)}$$

Stresses

$$\sigma = \frac{F}{A}, \text{ hence } \sigma_s = \frac{P_{st}}{A_s} = \frac{37 \times 10^3}{500 \times 10^{-6}} = 74 \text{ MPa (Answer)}$$

$$\sigma_b = \frac{P_{st}}{A_b} = \frac{25 \times 10^3}{900 \times 10^{-6}} = 27.8 \text{ MPa (Answer)}$$

**Example 3:**

For assembly shown in the figure. Determine the stress in each of the two vertical rods if the temperature rises 40 °C after the load  $P=50 \text{ kN}$  is applied. Neglect the deformation and mass of the horizontal bar  $AB$ . Use  $E_a=70 \text{ GPa}$ ,  $\alpha_a=23.0 \mu\text{m/m}\cdot^\circ\text{C}$ ,  $A_a=900 \text{ mm}^2$ ,  $E_s=200 \text{ GPa}$ ,  $\alpha_s=11.7 \mu\text{m/m}\cdot^\circ\text{C}$  and  $A_s=600 \text{ mm}^2$ .

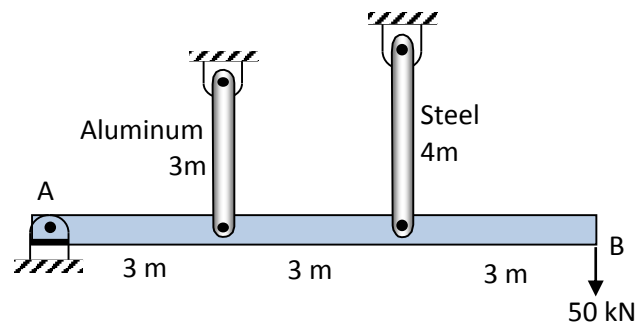

**Solution:**

$$\sum M_A = 0: \quad 50 \times 10^3 \times 9 - F_s \times 6 - F_a \times 3 = 0$$

$$2F_s + F_a = 150 \times 10^3 \quad (1)$$

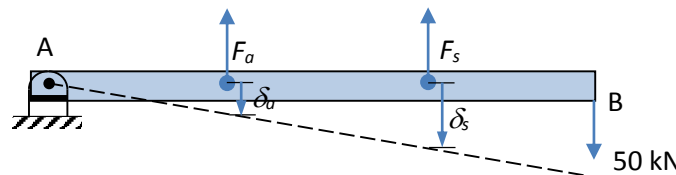

Deformation

$$\frac{\delta_s}{6} = \frac{\delta_a}{3} \rightarrow \delta_s = 2\delta_a$$



$$\alpha_s(\Delta T)L_s + \frac{F_s L_s}{A_s E_s} = 2 \left( \alpha_a(\Delta T)L_a + \frac{F_a L_a}{A_a E_a} \right)$$

$$11.7 \times 10^{-6} \times 40 \times 4 + \frac{F_s \times 4}{600 \times 10^{-6} \times 200 \times 10^9} = 2 \left( 23 \times 10^{-6} \times 40 \times 3 + \frac{F_a \times 3}{900 \times 10^{-6} \times 70 \times 10^9} \right)$$

$$F_s - 2.857F_a = 109.44 \text{ kN} \quad (2)$$

Solve (1) and (2) for  $F_s$  and  $F_a$ ,

$$F_s = 80.4 \text{ kN and } F_a = -10.17 \text{ kN}$$

### Stresses

$$\sigma_s = \frac{F_s}{A_s} = \frac{80.4 \times 10^3}{600 \times 10^{-6}} = 11.3 \text{ MPa (Answer)}$$

$$\sigma_a = \frac{F_a}{A_a} = \frac{10.17 \times 10^3}{900 \times 10^{-6}} = 134 \text{ MPa (Answer)}$$

### Example 4:

A rod is composed of three segments, as shown in the figure. Compute the stress induced in each material by a temperature drop  $30^\circ\text{C}$  if (a) the walls are rigid and (b) the walls spring together by  $0.3\text{mm}$ . Assume  $E_a=70 \text{ GPa}$ ,  $\alpha_a=23.0 \mu\text{m/m}\cdot^\circ\text{C}$ ,  $A_a=1200 \text{ mm}^2$ ,  $E_b=83 \text{ GPa}$ ,  $\alpha_b=18.9 \mu\text{m/m}\cdot^\circ\text{C}$ ,  $A_b=2400 \text{ mm}^2$ ,  $E_s=200 \text{ GPa}$ ,  $\alpha_s=11.7 \mu\text{m/m}\cdot^\circ\text{C}$  and  $A_s=600 \text{ mm}^2$ .

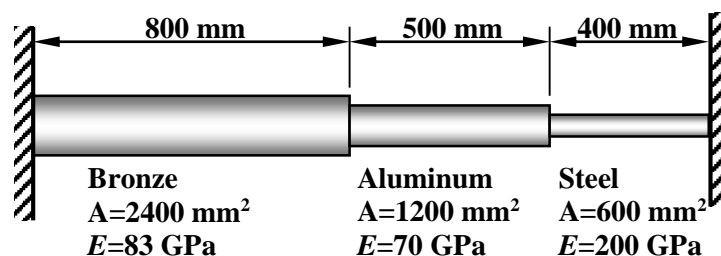

### Solution

$$a) \quad \sum(\delta_{th} + \delta_F) = 0$$



$$18.9 \times 10^{-6} \times 30 \times 0.8 - \frac{F * 0.8}{2400 \times 10^{-6} \times 83 \times 10^9} + 23 \times 10^{-6} \times 30 \times 0.5$$

$$- \frac{F \times 0.5}{1200 \times 10^{-6} \times 70 \times 10^9} + 11.7 \times 10^{-6} \times 30 \times 0.4$$

$$- \frac{F \times 0.4}{600 \times 10^{-6} \times 200 \times 10^9} = 0$$

$$F=70.592 \text{ kN}$$

### Stresses

$$\sigma_s = \frac{F_s}{A_s} = \frac{70.592 \times 10^3}{600 \times 10^{-6}} = 117.65 \text{ MPa} \quad (\text{Answer})$$

$$\sigma_a = \frac{F_a}{A_a} = \frac{70.592 \times 10^3}{1200 \times 10^{-6}} = 58.82 \text{ MPa} \quad (\text{Answer})$$

$$\sigma_b = \frac{F_b}{A_b} = \frac{70.592 \times 10^3}{2400 \times 10^{-6}} = 29.41 \text{ MPa} \quad (\text{Answer})$$

$$b) \quad \Sigma(\delta_{th} + \delta_F) = 0.3 \times 10^{-3}$$

$$18.9 \times 10^{-6} \times 30 \times 0.8 - \frac{F * 0.8}{2400 \times 10^{-6} \times 83 \times 10^9} + 23 \times 10^{-6} \times 30 \times 0.5$$

$$- \frac{F \times 0.5}{1200 \times 10^{-6} \times 70 \times 10^9} + 11.7 \times 10^{-6} \times 30 \times 0.4$$

$$- \frac{F \times 0.4}{600 \times 10^{-6} \times 200 \times 10^9} = 0.3 * 10^{-3}$$

$$F=49.15 \text{ KN}$$

### Stresses

$$\sigma_s = \frac{F_s}{A_s} = \frac{49.15 \times 10^3}{600 \times 10^{-6}} = 81.91 \text{ MPa} \quad (\text{Answer})$$

$$\sigma_a = \frac{F_a}{A_a} = \frac{49.15 \times 10^3}{1200 \times 10^{-6}} = 40.95 \text{ MPa} \quad (\text{Answer})$$

$$\sigma_b = \frac{F_b}{A_b} = \frac{49.15 \times 10^3}{2400 \times 10^{-6}} = 20.47 \text{ MPa} \quad (\text{Answer})$$

### **Example 5:**

A rigid horizontal bar of negligible mass is connected to two rods as shown in the figure. If the system is initially stress-free; determine the temperature change that will cause a tensile stress of 60 MPa in the steel rod. Assume  $E_s=200 \text{ GPa}$ ,  $\alpha_s=11.7 \mu\text{m/m}\cdot^\circ\text{C}$  and  $A_s=900 \text{ mm}^2$ ,  $E_b=83 \text{ GPa}$ ,  $\alpha_b=18.9 \mu\text{m/m}\cdot^\circ\text{C}$ ,  $A_b=1200 \text{ mm}^2$ .

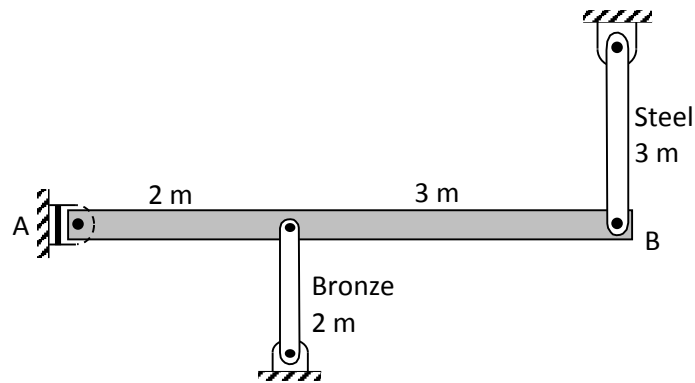

**Solution:**

$$\sigma_s = \frac{F_s}{A_s} \rightarrow F_s = A_s \sigma_s$$

Statics

$$\sum M_A = 0: \quad F_s * 5 = F_b * 2$$

$$\therefore F_b = \frac{5}{2} F_s \quad (1)$$

Since  $\sigma_s = 60$  MPa, then  $F_s = A_s \sigma_s = 900 \times 10^{-6} \times 60 \times 10^6 = 54$  kN,

Use equation (1),  $F_b = 135$  kN

Deformation

$$\frac{\delta_s}{5} = \frac{\delta_b}{2} \rightarrow \delta_b = \frac{5}{2} \delta_s$$

$$\alpha_b (\Delta T) L_b + \frac{F_b L_b}{A_b E_b} = \frac{5}{2} \left( \alpha_s (\Delta T) L_s + \frac{F_s L_s}{A_s E_s} \right)$$

$$18.9 \times 10^{-6} \times \Delta T \times 2 + \frac{135 \times 10^3 \times 2}{1200 \times 10^{-6} \times 83 \times 10^9} = \frac{5}{2} \left( 11.7 \times 10^{-6} \times \Delta T \times 3 + \frac{54 \times 10^3 \times 3}{900 \times 10^{-6} \times 200 \times 10^9} \right)$$

$$\Delta T = ?$$



The following example from:

- Beer F.P., Johnston E.R., *Mechanics of Materials*, McGraw-Hill, New York, 2012.

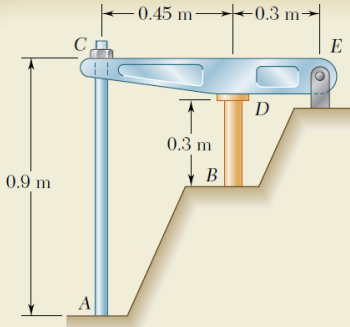

### SAMPLE PROBLEM 2.4

The rigid bar  $CDE$  is attached to a pin support at  $E$  and rests on the 30-mm-diameter brass cylinder  $BD$ . A 22-mm-diameter steel rod  $AC$  passes through a hole in the bar and is secured by a nut which is snugly fitted when the temperature of the entire assembly is  $20^\circ\text{C}$ . The temperature of the brass cylinder is then raised to  $50^\circ\text{C}$  while the steel rod remains at  $20^\circ\text{C}$ . Assuming that no stresses were present before the temperature change, determine the stress in the cylinder.

Rod $AC$ : Steel	Cylinder $BD$ : Brass
$E = 200 \text{ GPa}$	$E = 105 \text{ GPa}$
$\alpha = 11.7 \times 10^{-6}/^\circ\text{C}$	$\alpha = 20.9 \times 10^{-6}/^\circ\text{C}$

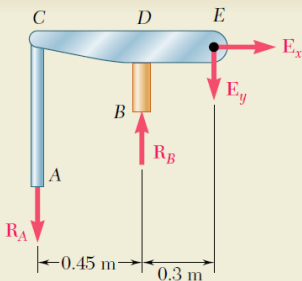

### SOLUTION

**Statics.** Considering the free body of the entire assembly, we write

$$+\uparrow \sum M_E = 0: \quad R_A(0.75 \text{ m}) - R_B(0.3 \text{ m}) = 0 \quad R_A = 0.4R_B \quad (1)$$

**Deformations.** We use the method of superposition, considering  $R_B$  as redundant. With the support at  $B$  removed, the temperature rise of the cylinder causes point  $B$  to move down through  $\delta_T$ . The reaction  $R_B$  must cause a deflection  $\delta_1$  equal to  $\delta_T$  so that the final deflection of  $B$  will be zero (Fig. 3).

**Deflection  $\delta_T$ .** Because of a temperature rise of  $50^\circ - 20^\circ = 30^\circ\text{C}$ , the length of the brass cylinder increases by  $\delta_T$ .

$$\delta_T = L(\Delta T)\alpha = (0.3 \text{ m})(30^\circ\text{C})(20.9 \times 10^{-6}/^\circ\text{C}) = 188.1 \times 10^{-6} \text{ m} \downarrow$$

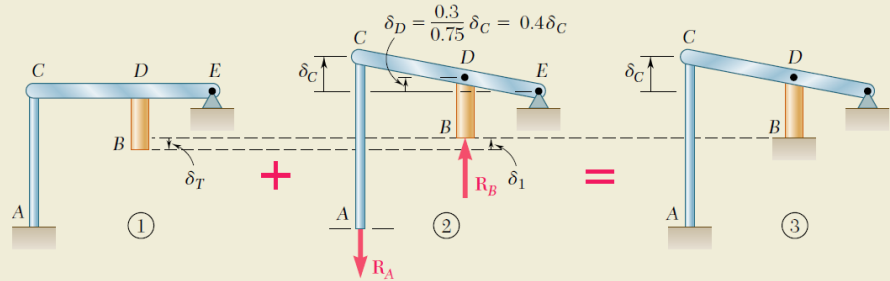

**Deflection  $\delta_1$ .** We note that  $\delta_D = 0.4\delta_C$  and  $\delta_1 = \delta_D + \delta_{B/D}$ .

$$\delta_C = \frac{R_A L}{AE} = \frac{R_A(0.9 \text{ m})}{\frac{1}{4}\pi(0.022 \text{ m})^2(200 \text{ GPa})} = 11.84 \times 10^{-9} R_A \uparrow$$

$$\delta_D = 0.40\delta_C = 0.4(11.84 \times 10^{-9} R_A) = 4.74 \times 10^{-9} R_A \uparrow$$

$$\delta_{B/D} = \frac{R_B L}{AE} = \frac{R_B(0.3 \text{ m})}{\frac{1}{4}\pi(0.03 \text{ m})^2(105 \text{ GPa})} = 4.04 \times 10^{-9} R_B \uparrow$$

We recall from (1) that  $R_A = 0.4R_B$  and write

$$\delta_1 = \delta_D + \delta_{B/D} = [4.74(0.4R_B) + 4.04R_B]10^{-9} = 5.94 \times 10^{-9} R_B \uparrow$$

But  $\delta_T = \delta_1$ :  $188.1 \times 10^{-6} \text{ m} = 5.94 \times 10^{-9} R_B \quad R_B = 31.7 \text{ kN}$

**Stress in Cylinder:**  $\sigma_B = \frac{R_B}{A} = \frac{31.7 \text{ kN}}{\frac{1}{4}\pi(0.03 \text{ m})^2} \quad \sigma_B = 44.8 \text{ MPa} \blacktriangleleft$



## TORSION OF THIN-WALLED TUBES

Consider the thin-walled tube subjected to the torque  $T$  shown in Figure 1(a). We assume the tube to be of constant cross section, but the wall thickness  $t$  is allowed to vary within the cross section. The surface that lies midway between **the inner and outer boundaries of the tube** is called the **middle surface**. If  $t$  is small compared to the overall dimensions of the cross section, the shear stress  $\tau$  induced by torsion can be shown to be almost constant through the wall thickness of the tube and directed tangent to the middle surface, as shown in Figure 1(b). It is convenient to introduce the concept of **shear flow**  $q$ , defined as the shear force per unit edge length of the middle surface. Thus, the shear flow is

$$q = \tau t \quad (1)$$

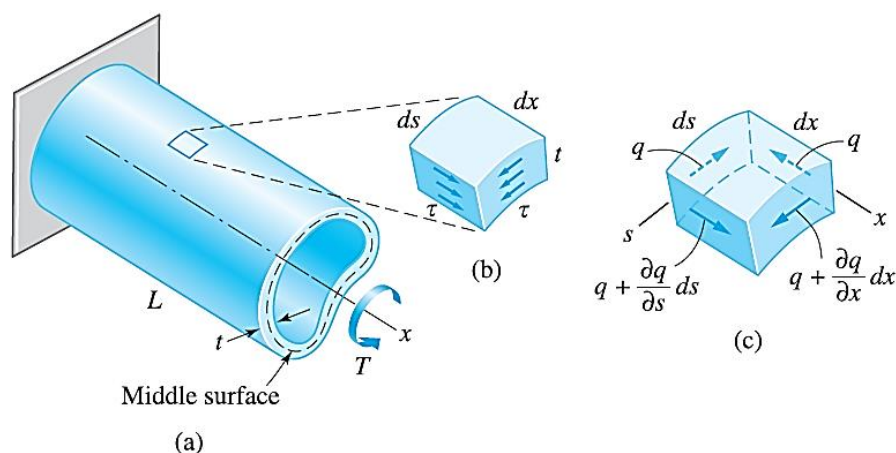

**Figure 1:** (a) Thin-walled tube in torsion; (b) shear stress in the wall of the tube; (c) shear flows on wall element.



The shear flow is **constant** throughout the tube, as explained in what follows. Considering the equilibrium of the element shown in Figure 1(c). In labeling the shear flows, we assume that  $q$  varies in the longitudinal ( $x$ ) as well as the circumferential ( $s$ ) directions. Thus, the terms  $(\partial q / \partial x) dx$  and  $(\partial q / \partial s) ds$  represent the changes in the shear flow over the distances  $dx$  and  $ds$ , respectively. The force acting on each side of the element is equal to the shear flow multiplied by the edge length, resulting in the equilibrium equations

$$\sum F_x = 0: \quad \left( q + \frac{\partial q}{\partial s} ds \right) dx - q dx = 0$$

$$\sum F_s = 0: \quad \left( q + \frac{\partial q}{\partial x} dx \right) ds - q ds = 0$$

which yield  $\frac{\partial q}{\partial s} = \frac{\partial q}{\partial x} = 0$ , thus proving that the **shear flow is constant throughout the tube**.

To relate the shear flow to the applied torque  $T$ , consider the cross section of the tube in Figure 2. The shear force acting over the infinitesimal edge length  $ds$  of the middle surface is  $dP = q ds$ . The moment of this force about an arbitrary point  $O$  in the cross section is  $r dP = (q ds) r$ , where  $r$  is the perpendicular distance of  $O$  from the line of action of  $dP$ . Equilibrium requires that the sum of these moments must be equal to the applied torque  $T$ ; that is,

$$T = \oint_S q r ds \quad (2)$$

where the integral is taken over the closed curve formed by the intersection of the middle surface and the cross section, called the **median line**.

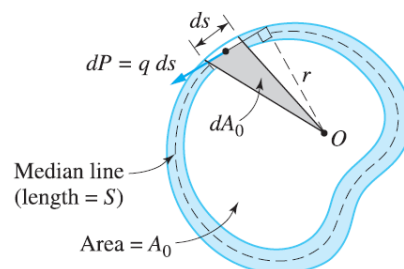

**Figure 2:** Calculating the torque  $T$  on the cross section of the tube.



Since  $q$  is constant, equation (2) can be written as  $T = q \oint_S r ds$ . From Figure 2 it can be seen that  $dA_0 = \frac{1}{2} r ds$ , where  $dA_0$  is the area of the shaded triangle. Therefore,  $\oint_S r ds = 2A_0$ , where  $A_0$  is the area of the cross section that is enclosed by the *median line*. Consequently, equation (2) becomes

$$T = 2A_0 q$$

from the shear flow is

$$q = \frac{T}{2A_0} \quad (3)$$

The angle of twist of the tube can be found by equating the work done by the shear stress in the tube to the work of the applied torque  $T$ . From Figure 3, the work done on the element is,

$$dU = \frac{1}{2} (\text{force} \times \text{distance}) = \frac{1}{2} (q ds \times \gamma dx)$$

where  $q ds$  is the elemental shear force which moves a distance  $\gamma dx$ , Figure 3.

Using Hooke's law, i.e.  $\gamma = \frac{\tau}{G} = q/(Gt)$ , the above equation may be written as,

$$dU = \frac{q^2}{2Gt} ds dx \quad (4)$$

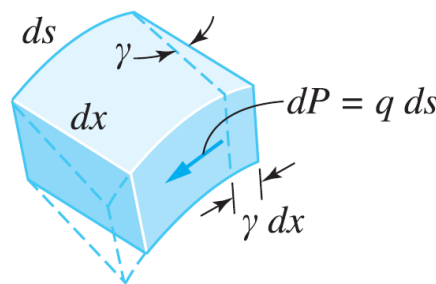

**Figure 3:** Deformation of element caused by shear flow.

Since  $q$  and  $G$  are constants and  $t$  is independent of  $x$ , the work  $U$  is obtained from equation (4) over the middle surface of the tube,

$$U = \frac{q^2}{2G} \int_0^L \left( \oint_S \frac{ds}{t} \right) dx = \frac{q^2 L}{2G} \left( \oint_S \frac{ds}{t} \right) \quad (5)$$



Conservation of energy requires  $U$  to be equal to the work of the applied torque; that is,  $U = T \theta/2$ . Then, using equation (3), equation (5) will be,

$$\left(\frac{T}{2A_0}\right)^2 \frac{L}{2G} \left(\oint_S \frac{ds}{t}\right) = \frac{1}{2} T \theta$$

from which the angle of twist of the tube is

$$\theta = \frac{TL}{4GA_0^2} \left(\oint_S \frac{ds}{t}\right) \quad (6)$$

If  $t$  is **constant**, we have  $\oint_S (ds/t) = S/t$ , where  $S$  is the length of the **median line**. Therefore, equation (6) becomes

$$\theta = \frac{TLS}{4GA_0^2 t} = \frac{\tau LS}{2A_0 G} \quad (7)$$

For closed sections which have constant thickness over specified lengths but varying from one part of the perimeter to another:

$$\theta = \frac{TL}{4GA_0^2} \left(\frac{S_1}{t_1} + \frac{S_2}{t_2} + \frac{S_3}{t_3} + \dots \text{etc.}\right) \quad (8)$$

### Thin-Walled Cellular Sections

The above theory may be applied to the solution of problems involving cellular sections of the type shown in Figure 4.

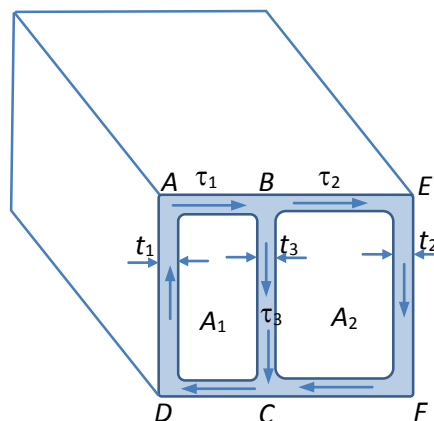

**Figure 4:** Thin-walled cellular section.



Assume the length  $CDAB$  is of constant thickness  $t_1$  and subjected therefore to a constant shear stress  $\tau_1$ . Similarly,  $BEFC$  is of thickness  $t_2$  and stress  $\tau_2$  with  $BC$  of thickness  $t_3$  and stress  $\tau_3$ .

Considering the equilibrium of complementary shear stresses on a longitudinal section at  $B$ , it follows that

$$q_1 = q_2 + q_3$$

or

$$\tau_1 t_1 = \tau_2 t_2 + \tau_3 t_3 \quad (9)$$

The total torque for the section is then found as the sum of the torques on the two cells by application of equation (3) to the two cells and adding the result,

$$T = 2q_1 A_1 + 2q_2 A_2 = 2(\tau_1 t_1 A_1 + \tau_2 t_2 A_2) \quad (10)$$

The angle of twist will be common to both cells, i.e.,

$$\theta = \frac{L}{2G} \left( \frac{\tau_1 S_1 + \tau_3 S_3}{A_1} \right) = \frac{L}{2G} \left( \frac{\tau_2 S_2 - \tau_3 S_3}{A_2} \right) \quad (11)$$

where  $S_1$ ,  $S_2$  and  $S_3$  are the median line perimeters  $CDAB$ ,  $BEFC$  and  $BC$  respectively.

**Note:** The negative sign appears in the final term because the shear flow along  $BC$  for this cell opposes that in the remainder of the perimeter.



**Example 1:**

A thin-walled member 1.2 m long has the cross-section shown in the figure. Determine the maximum torque which can be carried by the section if the angle of twist is limited to  $10^\circ$ . What will be the maximum shear stress when this maximum torque is applied? For the material of the member  $G = 80 \text{ GN/m}^2$ .

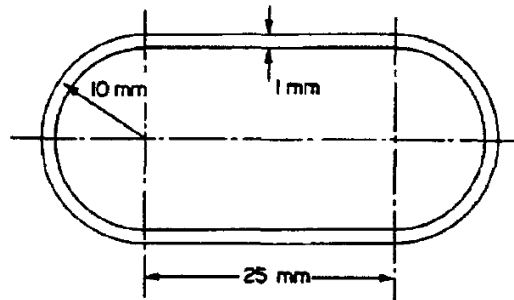

**Solution:**

Now, perimeter of median line =  $s = (2 \times 25 + 2\pi \times 10) \text{ mm}$   
 $= 112.8 \text{ mm}$

area enclosed by median =  $A = (20 \times 25 + \pi \times 10^2) \text{ mm}^2$   
 $= 814.2 \text{ mm}^2$

From eqn ( 7 ),  $\theta = \frac{TLs}{4A^2 Gt}$

$\therefore \frac{10 \times 2\pi}{360} = \frac{T \times 1.2 \times 112.8 \times 10^{-3}}{4(814.2 \times 10^{-6})^2 \times 80 \times 10^9 \times 1 \times 10^{-3}}$

i.e. maximum torque possible,

$$T = \frac{20\pi \times 4 \times 814.2^2 \times 80 \times 10^{-6}}{360 \times 1.2 \times 112.8 \times 10^{-3}}$$

$$= 273 \text{ Nm}$$

From eqn. ( 3 ),

$$\tau_{\max} = \frac{T}{2At}$$

$$= \frac{273}{2 \times 814.2 \times 10^{-6} \times 1 \times 10^{-3}}$$

$$= 168 \times 10^6 = 168 \text{ MN/m}^2$$

The maximum stress produced is **168 MN/m<sup>2</sup>**.



**Example 2:**

The median dimensions of the two cells shown in the cellular section of the figure below are  $A_1 = 20 \text{ mm} \times 40 \text{ mm}$  and  $A_2 = 50 \text{ mm} \times 40 \text{ mm}$  with wall thicknesses  $t_1 = 2 \text{ mm}$ ,  $t_2 = 1.5 \text{ mm}$  and  $t_3 = 3 \text{ mm}$ . If the section is subjected to a torque of  $320 \text{ Nm}$ , determine the angle of twist per unit length and the maximum shear stress set up. The section is constructed from a light alloy with a modulus of rigidity  $G = 30 \text{ GN/m}^2$ .

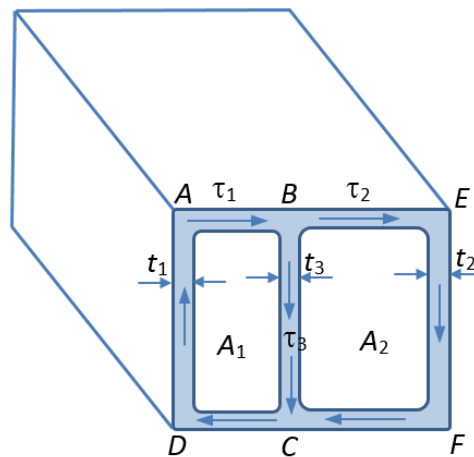

**Solution:**

From eqn. (10),

$$320 = 2(\tau_1 \times 2 \times 20 \times 40 + \tau_2 \times 1.5 \times 50 \times 40) \times 10^{-9} \quad (1)$$

From eqn. (11),

$$2 \times 30 \times 10^9 \times \theta = \frac{1}{20 \times 40 \times 10^{-6}} (\tau_1 (40 + 2 \times 20) 10^{-3} + \tau_3 \times 40 \times 10^{-3}) \quad (2)$$

and,

$$2 \times 30 \times 10^9 \times \theta = \frac{1}{50 \times 40 \times 10^{-6}} (\tau_2 (40 + 2 \times 50) 10^{-3} - \tau_3 \times 40 \times 10^{-3}) \quad (3)$$

Equating (2) and (3),

$$40\tau_1 = 28\tau_2 - 28\tau_3 \quad (4)$$

From eqn. (9),

$$2\tau_1 = 1.5\tau_2 + 3\tau_3 \quad (5)$$

The **negative sign** indicates that the direction of shear flow in the wall of thickness  $t_3$  is reversed from that shown in the figure.



Solving equations (1), (4) and (5) for  $\tau_1$ ,  $\tau_2$  and  $\tau_3$ ,

$$\tau_1 = 27.6 \text{ MPa}, \quad \tau_2 = 38.6 \text{ MPa} \quad \text{and} \quad \tau_3 = -0.9 \text{ MPa}$$

The **maximum shear stress** present in the section is thus **38.6 MN/m<sup>2</sup>** in the 1.5 mm wall thickness.

From eqn. (3),

$$2 \times 30 \times 10^9 \times \theta = \frac{1 \times 10^3}{20 \times 40 \times 10^{-6}} (27.6 \times (40 + 2 \times 20) - 0.9 \times 40)$$

$$\therefore \theta = 0.04525 \text{ rad.} = 2.592^\circ \text{ (Answer)}$$

The following example from:

- Pytel A., Kiusalaas J., *Mechanics of Materials*, 2<sup>nd</sup> Edition, Cengage Learning, Stamford, 2010.

### Sample Problem 3.7

An aluminum tube, 1.2 m long, has the semicircular cross section shown in the figure. If stress concentrations at the corners are neglected, determine (1) the torque that causes a maximum shear stress of 40 MPa, and (2) the corresponding angle of twist of the tube. Use  $G = 28 \text{ GPa}$  for aluminum.

#### Solution

**Part 1**

Because the shear flow is constant in a prismatic tube, the maximum shear stress occurs in the thinnest part of the wall, which is the semicircular portion with  $t = 2 \text{ mm}$ . Therefore, the shear flow that causes a maximum shear stress of 40 MPa is

$$q = \tau t = (40 \times 10^6)(0.002) = 80 \times 10^3 \text{ N/m}$$

The cross-sectional area enclosed by the median line is

$$A_0 = \frac{\pi r^2}{2} = \frac{\pi(0.025)^2}{2} = 0.9817 \times 10^{-3} \text{ m}^2$$

which results in the torque—see Eq. (3.8a):

$$T = 2A_0q = 2(0.9817 \times 10^{-3})(80 \times 10^3) = 157.07 \text{ N} \cdot \text{m} \quad \text{Answer}$$

**Part 2**

The cross section consists of two parts, labeled ① and ② in the figure, each having a constant thickness. Hence, we can write

$$\oint \frac{ds}{t} = \frac{1}{t_1} \int_{S_1} ds + \frac{1}{t_2} \int_{S_2} ds = \frac{S_1}{t_1} + \frac{S_2}{t_2}$$

where  $S_1$  and  $S_2$  are the lengths of the median lines of parts ① and ②, respectively. Therefore,

$$\oint \frac{ds}{t} = \frac{\pi r}{t_1} + \frac{2r}{t_2} = \frac{\pi(25)}{2} + \frac{2(25)}{3} = 55.94$$

and Eq. (3.9a) yields for the angle of twist

$$\theta = \frac{TL}{4GA_0^2} \oint \frac{ds}{t} = \frac{157.07(1.2)}{4(28 \times 10^9)(0.9817 \times 10^{-3})^2} (55.94)$$

$$= 0.0977 \text{ rad} = 5.60^\circ \quad \text{Answer}$$





# TORSION OF CIRCULAR SHAFT

## Introduction

In many engineering applications, members are required to carry torsional loads. In this lecture, we consider the torsion of circular shafts. Because a circular cross section is an efficient shape for resisting torsional loads, circular shafts are commonly used to transmit power in rotating machinery. Derivation of the equations used in the analysis follows these steps:

- Make simplifying assumptions about the deformation based on experimental evidence.
- Determine the strains that are geometrically compatible with the assumed deformations.
- Use Hooke's law to express the equations of compatibility in terms of stresses.
- Derive the equations of equilibrium. (These equations provide the relationships between the stresses and the applied loads.)

## Torsion of Circular Shafts

Consider the solid circular shaft, shown in the Figure 2.1, and subjected to a torque  $T$  at the end of the shaft. The fiber  $AB$  on the outside surface, which is originally straight, will be twisted into a helix  $AB'$  as the shaft is twist through the angle  $\theta$ . During the deformation, the cross sections remain circular (NOT distorted in any manner) - they remain plane, and the radius  $r$  does not change.



Besides, the length  $L$  of the shaft remains constant. Based on these observations, the following assumptions are made:

- The material is homogeneous, i.e. of uniform elastic properties throughout.
- The material is elastic, following Hooke's law with shear stress proportional to shear strain.
- The stress does not exceed the elastic limit or limit of proportionality.
- Circular cross sections **remain plane** (do not warp) and perpendicular to the axis of the shaft.
- Cross sections **do not deform** (there is no strain in the plane of the cross section).
- The **distances between cross sections do not change** (the axial normal strain is zero).

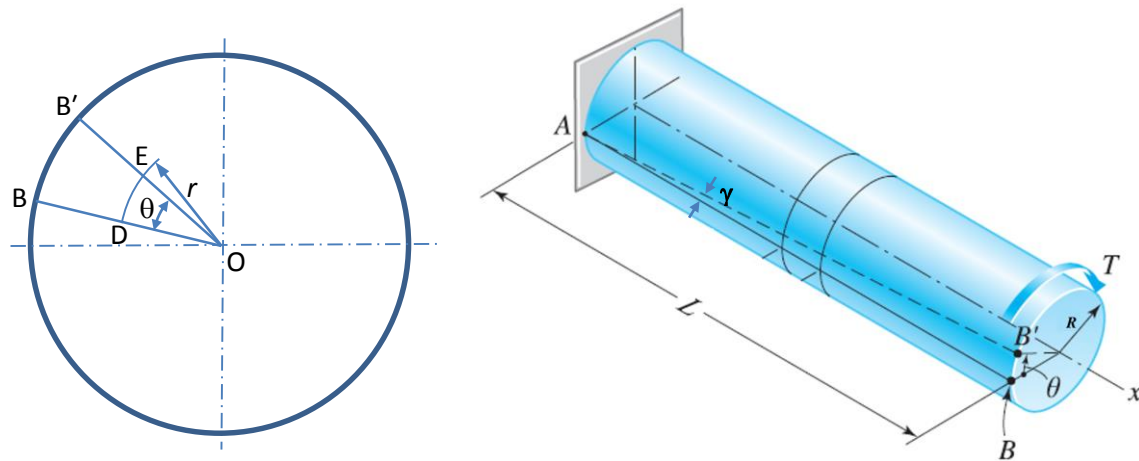

**Figure 2.1:** Deformation of a circular shaft caused by the torque  $T$ .

$$\delta_s = DE = r\theta \quad (1)$$

where the subscript  $s$  denotes *shear*,  $r$  is the distance from the origin to any interested fiber, and  $\theta$  is the angle of twist.

From Figure 2.1,

$$\gamma L = r\theta$$

The unit deformation of this fiber is,

$$\gamma = \frac{\delta_s}{L} = \frac{r\theta}{L} \quad (2)$$

Shear stress can be determined using Hooke's law as:



$$\tau = G\gamma = G \left( \frac{r\theta}{L} \right) \quad (3)$$

**Note:** since  $\tau = \left( \frac{G\theta}{L} \right) r = \text{const.}r$ , therefore, the conclusion is that the shearing stress at any internal fiber varies linearly with the radial distance from the axis of the shaft.

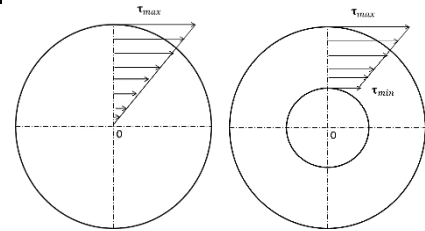

For the shaft to be in equilibrium, the resultant of the shear stress acting on a cross section must be equal to the internal torque  $T$  acting on that cross section. Figure 2.2 shows a cross section of the shaft containing a differential element of area  $dA$  located at the radial distance  $r$  from the axis of the shaft. The shear force acting on this area is  $dF = \tau dA$ , directed perpendicular to the radius. Hence, the torque of  $dF$  about the center  $O$  is:

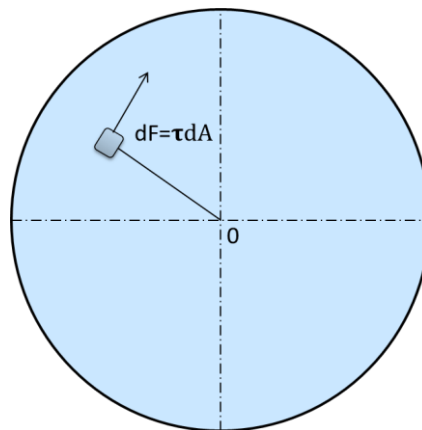

**Figure 2.2:** The resultant of the shear stress acting on the cross section.

$$T = \int r dF = \int r \tau dA \quad (4)$$

Substituting equation (3) into equation (4),

$$T_r = \int r \left( \frac{G\theta}{L} \right) r dA = \frac{G\theta}{L} \int r^2 dA$$

Since  $\int r^2 dA = J$ , the polar 2<sup>nd</sup> moment of area (or polar moment of inertia) of the cross section



$$T = \frac{G\theta}{L}J$$

Rearranging the above equation,

$$\theta = \frac{TL}{JG} \quad (5)$$

where  $T$  is the applied torque (N.m),  $L$  is length of the shaft (m),  $G$  is the shear modulus ( $\text{N/m}^2$ ),  $J$  is the polar moment of inertia ( $\text{m}^4$ ), and  $\theta$  is the angle of twist **in radians**.

From equations (5) and (3),

$$\tau = \left(\frac{G\theta}{L}\right)r = \frac{T}{J}r$$

or

$$\tau = \frac{Tr}{J} \quad (6)$$

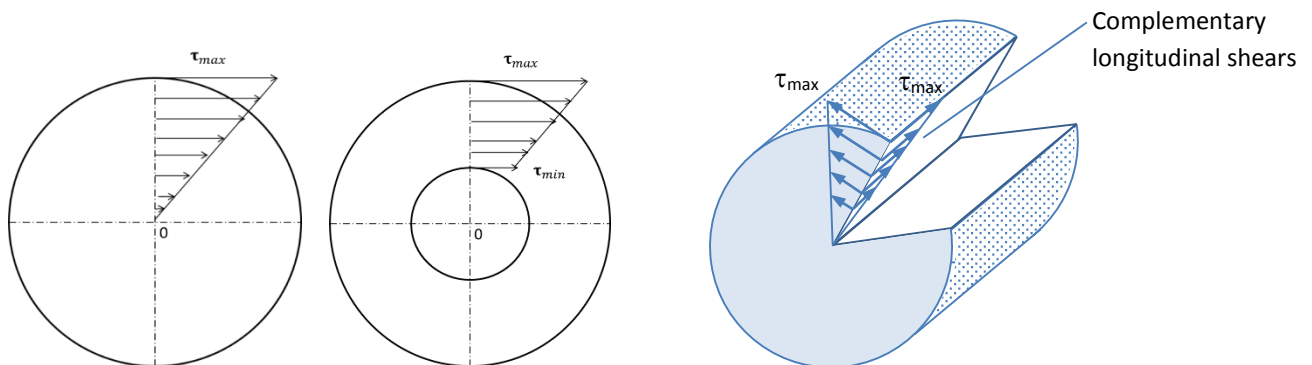

### Polar Moment of Inertia

- Solid Shaft

Consider the solid shaft shown, therefore,

$$J = \int r^2 dA = \int_0^R r^2 (2\pi r dr) = 2\pi \int_0^R r^3 dr$$

which yields,

$$J = 2\pi \left[ \frac{r^4}{4} \right]_0^R = \frac{\pi}{2} R^4$$

or

$$J = \frac{\pi d^4}{32}$$

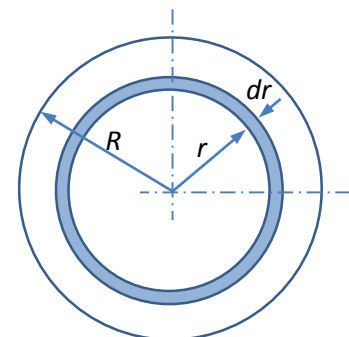

**Figure 2.3:** Shaft cross-section



- **Hollow Shaft**

The above procedure can be used for calculating the polar moment of inertia of the hollow shaft of inner radius  $R_i$  and outer radius  $R_o$ ,

$$J = 2\pi \int_{R_i}^{R_o} r^3 dr = \frac{\pi}{2} (R_o^4 - R_i^4)$$

or

$$J = \frac{\pi}{32} (D_o^4 - D_i^4)$$

- **Thin-Walled Hollow Shaft**

For thin-walled hollow shafts the values of  $D_o$  and  $D_i$  may be nearly equal, and in such cases there can be considerable errors in using the above equation involving the difference of two large quantities of similar value. It is therefore convenient to obtain an alternative form of expression for the polar moment of area. Therefore,

$$J = \int_0^R 2\pi r^3 dr = \sum (2\pi r dr) r^2 = \sum A r^2$$

where  $A = (2\pi r dr)$  is the area of each small element of Figure 2.3, i.e.  $J$  is the sum of the  $A r^2$  terms for all elements.

If a thin hollow cylinder is therefore considered as just one of these small elements with its wall thickness  $t = dr$ , then

$$J = A r^2 = (2\pi r t) r^2 = 2\pi r^3 t \quad (\text{approximately})$$

---

**Notes:** The maximum shear stress is found (at the surface of the shaft) by replacing  $r$  by the radius  $R$ , for solid shaft, or by  $R_o$ , for the hollow shaft, as

$$\tau_{max} = \frac{2T}{\pi R^3} = \frac{16T}{\pi D^3} \quad \rightarrow \text{solid shaft}$$

$$\tau_{max} = \frac{2TR}{\pi(R_o^4 - R_i^4)} = \frac{16TD_o}{\pi(D_o^4 - D_i^4)} \quad \rightarrow \text{hollow shaft}$$



---



## Composite Shafts - Series Connection

If two or more shafts of different material, diameter or basic form are connected together in such a way that each carries the same torque, then the shafts are said to be connected in series and the composite shaft so produced is therefore termed *series-connected*, as shown in Figure 2.4. In such cases the composite shaft strength is treated by considering each component shaft separately, applying the torsion theory to each in turn; **the composite shaft will therefore be as weak as its weakest component**. If relative dimensions of the various parts are required then a solution is usually effected by equating the torques in each shaft, e.g. for two shafts in series

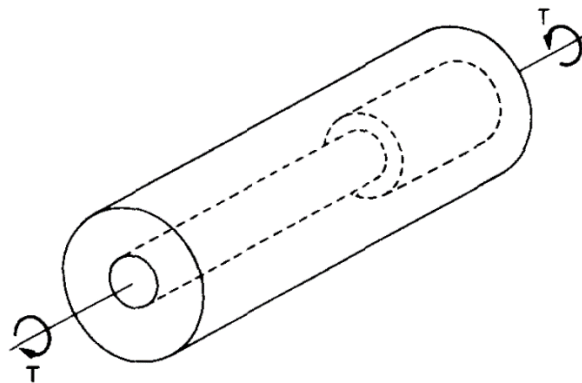
$$T = \frac{G_1 J_1 \theta_1}{L_1} = \frac{G_2 J_2 \theta_2}{L_2}$$



**Figure 2.4:** “Series connected” shaft - common torque

## Composite Shafts - Parallel Connection

If two or more materials are rigidly fixed together such that the applied torque is shared between them then the composite shaft so formed is said to be **connected in parallel** (Figure 2.5).

For parallel connection,

$$\text{Total Torque } T = T_1 + T_2 \quad (7)$$

In this case the angles of twist of each portion are equal and



$$\frac{T_1 L_1}{G_1 J_1} = \frac{T_2 L_2}{G_2 J_2} \quad (8)$$

or

$$\frac{T_1}{T_2} = \frac{G_1 J_1}{G_2 J_2} \left( \frac{L_2}{L_1} \right)$$

Thus two equations are obtained in terms of the torques in each part of the composite shaft and these torques can therefore be determined.

In case of **equal lengths**, equation (8) becomes

$$\frac{T_1}{T_2} = \frac{G_1 J_1}{G_2 J_2}$$

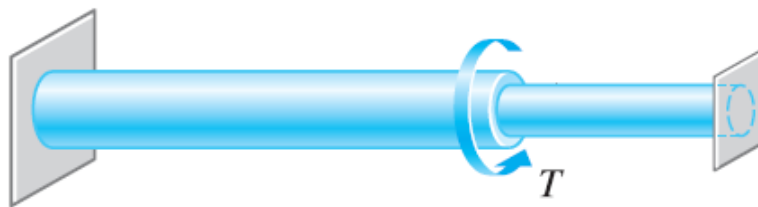

**Figure 2.5:** “Parallel connected” shaft - shared torque.

### **Power Transmitted by Shafts**

If a shaft carries a torque  $T$  Newton meters and rotates at  $\omega$  rad/s it will do work at the rate of

$$T\omega \text{ Nm/s (or joule/s).}$$

Now the rate at which a system works is defined as its power, the basic unit of power being the **Watt (1 Watt = 1 Nm/s)**.

Thus, the power transmitted by the shaft:

$$= T\omega \text{ Watts.}$$

Since the Watt is a very small unit of power in engineering terms use is normally made of S.I. multiples, i.e. kilowatts (kW) or megawatts (MW).



### Example1:

A solid shaft in a rolling mill transmits 20 kW at 120 r.p.m. Determine the diameter of the shaft if the shearing stress is not to exceed 40MPa and the angle of twist is limited to  $6^\circ$  in a length of 3m. Use  $G=83\text{GPa}$ .

### Solution

$$\text{Power} = T \omega$$

$$20 \times 10^3 = T \times 120 \times \frac{2\pi}{60}$$

$$\therefore T = \frac{20 \times 10^3}{4\pi} = 1590 \text{ N.m}$$

Since two design conditions have to be satisfied, i.e. strength (stress) consideration, and rigidity (angle of twist) consideration. The calculations will be as:

- Based on strength consideration  $\left( \tau_{max} = \frac{16T}{\pi D^3} \right)$

$$40 \times 10^6 = \frac{16 \times 1590}{\pi D^3}$$

$$\therefore D = 0.0587 = 58.7 \text{ mm}$$

- Based on rigidity consideration  $\left( \theta = \frac{TL}{JG} \right)$

$$\theta = \frac{TL}{\frac{\pi d^4}{32} G}$$

$$\therefore 6^\circ \times \frac{\pi}{180} = \frac{32 \times 1590 \times 3}{\pi d^4 \times 83 \times 10^9}$$

$$\therefore D = 0.0465 \text{ m} = 46.5 \text{ mm}$$

Therefore, the minimum diameter that satisfy both the strength and rigidity considerations is **D=58.7mm**. (Answer)





**Example 2:**

A steel shaft with constant diameter of 50 mm is loaded as shown in the figure by torques applied to gears fastened to it. Using  $G= 83 \text{ GPa}$ , compute in degrees the relative angle of rotation between gears A and D.

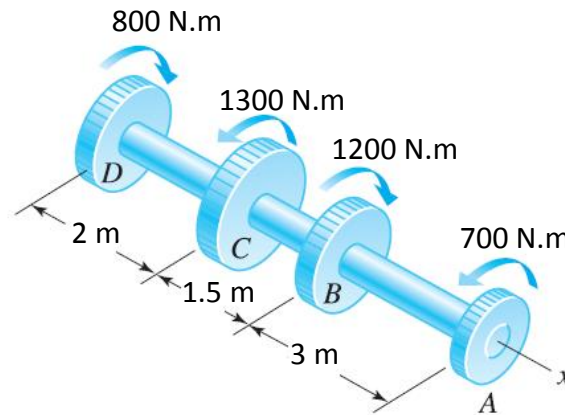

**Solution:**

It is convenient to represent the torques as vectors (using the right-hand rule) on the free body diagram, as shown in the figure.

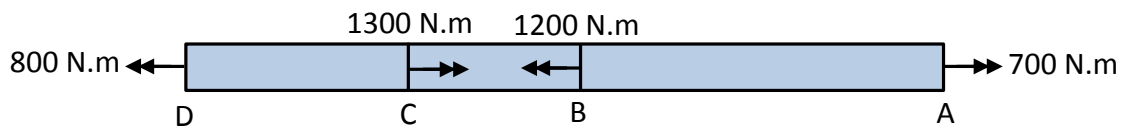

Using the equations of statics (i.e.  $\sum T = 0$ ), the internal torques are:  
 $T_{AB}=700\text{N.m}$ ,  $T_{BC}=-500\text{N.m}$  and  $T_{CD}=800\text{N.m}$ .

$$J_{AB} = J_{BC} = J_{CD} = J = \frac{\pi(0.05)^4}{32}$$

$$\begin{aligned} \theta_{A/D} &= \sum \frac{TL}{JG} = \frac{T_{AB}L_{AB}}{J_{AB}G} + \frac{T_{BC}L_{BC}}{J_{BC}G} + \frac{T_{CD}L_{CD}}{J_{CD}G} \\ &= \frac{1}{\frac{\pi(0.05)^4}{32} \times 83 \times 10^9} (700 \times 3 - 500 \times 1.5 + 800 \times 2) = 0.0579 \text{ rad.} \end{aligned}$$

$$\therefore \theta_{A/D} = 3.32^\circ \text{ (Answer)}$$



**Example3:**

A compound shaft made of two segments: solid steel and solid aluminum circular shafts. The compound shaft is built-in at A and B as shown in the figure. Compute the maximum shearing stress in each shaft. Given  $G_{al}=28\text{GPa}$ ,  $G_{st} = 83 \text{ GPa}$ .

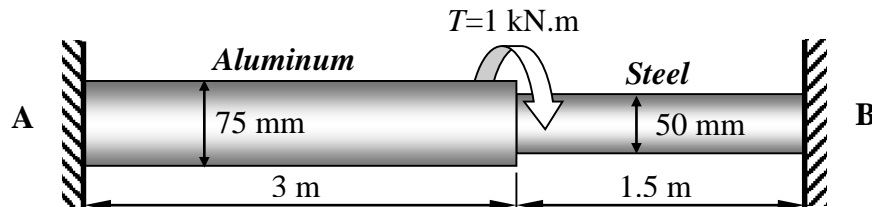

**Solution:**

This type of problem is a **statically indeterminate problem**, where the equation of statics (or equilibrium) is not enough to solve the problem. Therefore, one equation will be obtained from statics, and the other from the deformation.

- Statics

$$T_s + T_a = T = 1000 \quad (1)$$

- Deformation ( $\theta_s = \theta_a$ )

Since  $\theta_s = \theta_a$ , then  $\frac{T_s L_s}{J_s G_s} = \frac{T_a L_a}{J_a G_a}$ , which yield,

$$\frac{T_s \times 1.5}{\frac{\pi(0.05)^4}{32} \times 83 \times 10^9} = \frac{T_a \times 3}{\frac{\pi(0.075)^4}{32} \times 28 \times 10^9}$$

from which,

$$T_s = 1.17T_a \quad (2)$$

Solving equation (1) and (2):

$$T_a = 461 \text{ N.m} \quad \text{and} \quad T_s = 539 \text{ N.m}$$

- Stresses ( $\tau = \frac{Tr}{J}$ )

The maximum stress occur at the surface, i.e.  $\tau_{max} = \frac{16T}{\pi D^3}$



$$\tau_a = \frac{16 \cdot 461}{\pi (0.075)^3} = 5.57 \text{ MPa (Answer)}$$

$$\tau_s = \frac{16 \cdot 539}{\pi (0.05)^3} = 22.0 \text{ MPa (Answer)}$$

#### Example 4:

The compound shaft, shown in the figure, is attached to rigid supports. For bronze (AB)  $d=75\text{mm}$ ,  $G=35\text{GPa}$ ,  $\tau \leq 60\text{MPa}$ . For steel (BC),  $d=50\text{mm}$ ,  $G=83\text{GPa}$ ,  $\tau \leq 80\text{MPa}$ . Determine the ratio of lengths  $b/a$  so that each material will be stressed to its permissible limit, also find the torque  $T$  required.

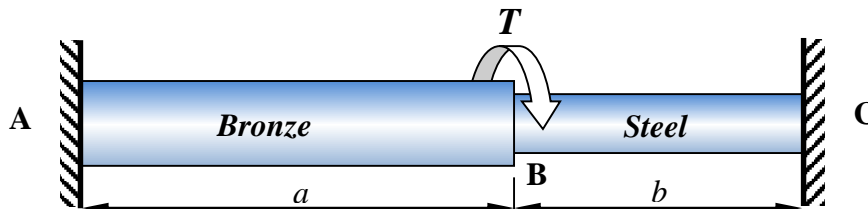

#### Solution:

- For bronze

$$\tau_b = \frac{T_b r}{J_b} \rightarrow 60 \times 10^6 = \frac{T_b \times 0.075/2}{\frac{\pi}{32} \times (0.075)^4}$$

From which

$$T_b = 4970 \text{ N.m}$$

For steel

$$\tau_s = \frac{T_s r}{J_s} \rightarrow 80 \times 10^6 = \frac{T_s \times 0.05/2}{\frac{\pi}{32} \times (0.05)^4}$$

From which

$$T_s = 1963.5 \text{ N.m}$$

Applied torque  $T = T_b + T_s = 6933.6 \text{ N.m}$  (Answer)



From the deformation  $\theta_s = \theta_b$ ,

$$\frac{T_s L_s}{J_s G_s} = \frac{T_b L_b}{J_b G_b} \rightarrow \frac{1963.5 \times b}{\frac{\pi}{32} \times (0.05)^4 \times 83 \times 10^9} = \frac{4970 \times a}{\frac{\pi}{32} \times (0.075)^4 \times 35 \times 10^9}$$

From which

**(b/a)=1.1856 (Answer)**

**Example 5:**

A compound shaft consisting of an aluminum segment and a steel is acted upon by two torque as shown in the figure. Determine the maximum permissible value of  $T$  subjected to the following conditions:

$\tau_s \leq 100\text{MPa}$ ,  $\tau_a \leq 70\text{MPa}$  , and the angle of rotation of the free end limited to  $12^\circ$ . Use  $G_s = 83\text{GPa}$  and  $G_a = 28\text{GPa}$ .

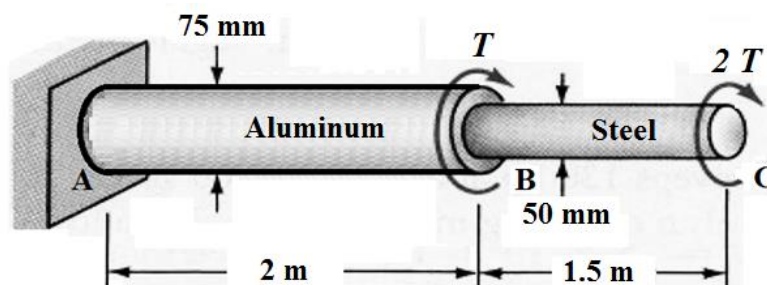

**Solution:**

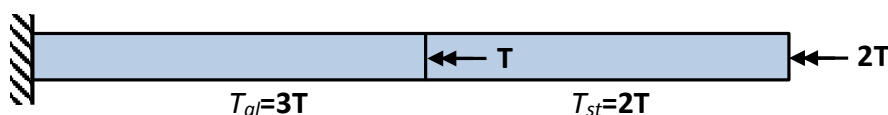

$$J_{st} = \frac{\pi}{32} \times (0.05)^4 = 6.136 \times 10^{-7} \text{m}^4$$

$$J_{al} = \frac{\pi}{32} \times (0.075)^4 = 3.106 \times 10^{-6} \text{m}^4$$

- For steel  $\left( \tau = \frac{Tr}{J} \right)$

$$100 \times 10^6 = \frac{2T \times 0.025}{6.136 \times 10^{-7}}$$

From which,  $T = 1.23 \text{ kN.m}$



- For aluminum

$$70 \times 10^6 = \frac{3T \times 0.075 / 2}{3.106 \times 10^{-6}}$$

From which,  $T = 1.93 \text{ kNm}$

- Deformation

$$\theta = \sum_{i=1}^2 \frac{TL}{JG} = \frac{T_a L_a}{J_a G_a} + \frac{T_s L_s}{J_s G_s}$$

$$12 \times \frac{\pi}{180} = \frac{3T \times 2}{3.106 \times 10^{-6} \times 28 \times 10^9} + \frac{2T \times 1.5}{6.136 \times 10^{-7} \times 83 \times 10^9}$$

From which,  $T = 1.64 \text{ kN.m}$

Therefore, the maximum safe value of torque ( $T$ ) is  $T = 1.23 \text{ kN.m}$  (Answer)

### Example 6:

The steel rod fits loosely inside the aluminum sleeve. Both components are attached to a rigid wall at  $A$  and joined together by a pin at  $B$ . Because of a slight misalignment of the pre-drilled holes, the torque  $T_o = 750 \text{ N.m}$  was applied to the steel rod before the pin could be inserted into the holes. Determine the torque in each component after  $T_o$  was removed. Use  $G = 80 \text{ GPa}$  for steel and  $G = 28 \text{ GPa}$  for aluminum.

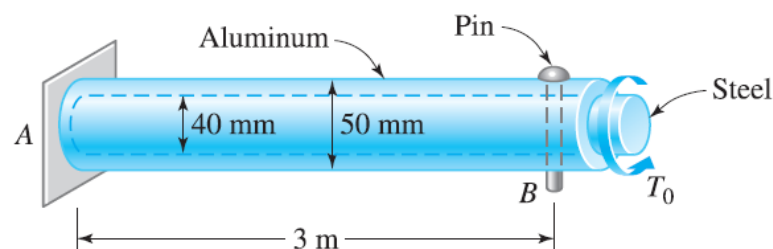

### Solution:

The initial torque  $T_o$  will cause an initial angle of twist to the steel rod,

$$\theta_o = \frac{T_o L}{J_s G_s} = \frac{750 \times 3}{\frac{\pi}{32} (0.04)^4 \times 80 \times 10^9} = 0.1119058 \text{ rad.}$$



When the pin was inserted into the holes with the removal of  $T_o$ , the system will stabilize in static equilibrium. This will cause some of the deformation of steel rod to be recovered, as shown in the figure. This relation may be expressed as,

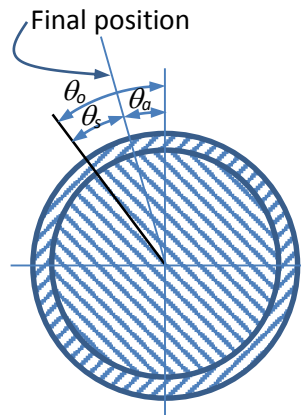

$$\theta_o = \theta_s + \theta_a$$

$$0.1119058 = \frac{T \times 3}{\frac{\pi}{32}(0.04)^4 \times 80 \times 10^9} + \frac{T \times 3}{\frac{\pi}{32}((0.05)^4 - (0.04)^4) \times 28 \times 10^9}$$

From which,  $T = 251.5 \text{ N.m}$  (Answer)