



The Najaf Experience ...

- ✓ Excellent teaching and research
- ✓ Outstanding study facilities
- ✓ Najaf city location
- ✓ High quality residences – guaranteed accommodation in your four years
- ✓ Ongoing investment programs
- ✓ College education since 1998

HEAT TRANSFER

انتقال الحرارة

اعداد الدكتور
علي شاکر باقر الجابري

HEAT TRANSFER

انتقال الحرارة

CHAPTER THREE STEADY HEAT CONDUCTION

3-1 STEADY HEAT CONDUCTION IN PLANE WALLS

3-2 Thermal Resistance Network

3-3 GENERALIZED THERMAL RESISTANCE NETWORKS

3-4 HEAT CONDUCTION IN CYLINDERS AND SPHERES

3-5 CRITICAL RADIUS OF INSULATION

3-6 HEAT TRANSFER FROM FINNED SURFACES

3-1 STEADY HEAT CONDUCTION IN PLANE WALLS

Consider a plane wall of thickness L and average thermal conductivity k . The two surfaces of the wall are maintained at constant temperatures of T_1 and T_2 . For one-dimensional steady heat conduction through the wall, we have $T(x)$. Then Fourier's law of heat conduction for the wall can be expressed as

$$\dot{Q}_{\text{cond, wall}} = -kA \frac{dT}{dx} \quad (\text{W}) \quad 3-1$$

where the rate of conduction heat transfer $\dot{Q}_{\text{cond, wall}}$ and the wall area A are constant. Thus we have $dT/dx = \text{constant}$, which means that *the temperature through the wall varies linearly with x* . That is, the temperature distribution in the wall under steady conditions is a *straight line* (Fig. 3–2).

Separating the variables in the above equation and integrating from $x = 0$, where $T(0) = T_1$, to $x = L$, where $T(L) = T_2$, we get

$$\int_{x=0}^L \dot{Q}_{\text{cond, wall}} dx = - \int_{T=T_1}^{T_2} kA dT \quad 3-2$$

Performing the integrations and rearranging gives

$$\dot{Q}_{\text{cond, wall}} = kA \frac{T_1 - T_2}{L} \quad (\text{W}) \quad 3-3$$

the rate of heat conduction through a plane wall is proportional to the average thermal conductivity, the wall area, and the temperature difference, but is inversely proportional to the wall thickness. Also, once the rate of heat conduction is available, the temperature $T(x)$ at any location x can be determined by replacing T_2 in Eq. 3–3 by T , and L by x .

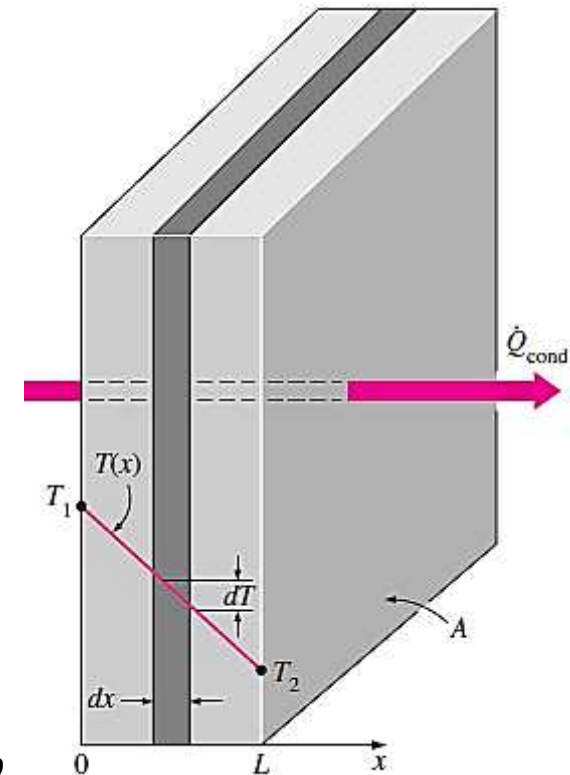

FIGURE 3–2

The Thermal Resistance Concept

Equation 3–3 for heat conduction through a plane wall can be rearranged as

$$\dot{Q}_{\text{cond, wall}} = \frac{T_1 - T_2}{R_{\text{wall}}} \quad (\text{W}) \quad (3-4)$$

where

$$R_{\text{wall}} = \frac{L}{kA} \quad (^\circ\text{C}/\text{W}) \quad (3-5)$$

is the *thermal resistance* of the wall against heat conduction or simply the **conduction resistance** of the wall. Note that the thermal resistance of a medium depends on the *geometry* and the *thermal properties* of the medium. The equation above for heat flow is analogous to the relation for *electric current flow* I , expressed as

$$I = \frac{V_1 - V_2}{R_e} \quad (3-6)$$

where $R_e = L/\sigma_e A$ is the *electric resistance* and $V_1 - V_2$ is the *voltage difference* across the resistance (σ_e is the electrical conductivity). Thus, the *rate of heat transfer* through a layer corresponds to the *electric current*, the *thermal resistance* corresponds to *electrical resistance*, and the *temperature difference* corresponds to *voltage difference* across the layer (Fig. 3–3).

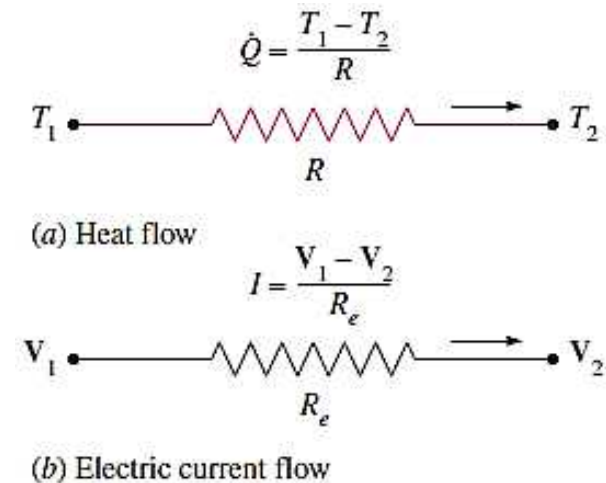

FIGURE 3–3

Consider convection heat transfer from a solid surface of area A_s and temperature T_s to a fluid whose temperature sufficiently far from the surface is T_∞ , with a convection heat transfer coefficient h . Newton's law of cooling for convection heat transfer rate $\dot{Q}_{\text{conv}} = hA_s(T_s - T_\infty)$ can be rearranged as

$$\dot{Q}_{\text{conv}} = \frac{T_s - T_\infty}{R_{\text{conv}}} \quad (\text{W}) \quad (3-7)$$

where

$$R_{\text{conv}} = \frac{1}{hA_s} \quad (^\circ\text{C}/\text{W}) \quad (3-8)$$

is the *thermal resistance* of the surface against heat convection, or simply the **convection resistance** of the surface (Fig. 3–4). Note that when the convection heat transfer coefficient is very large ($h \rightarrow \infty$), the convection resistance becomes *zero* and $T_s \approx T_\infty$. That is, the surface offers *no resistance to convection*, and thus it does not slow down the heat transfer process. This situation is approached in practice at surfaces where boiling and condensation occur. Also note that the surface does not have to be a plane surface. Equation 3–8 for convection resistance is valid for surfaces of any shape, provided that the assumption of $h = \text{constant}$ and uniform is reasonable.

When the wall is surrounded by a gas, the *radiation effects*, which we have ignored so far, can be significant and may need to be considered. The rate of radiation heat transfer between a surface of emissivity ε and area A_s at temperature T_s and the surrounding surfaces at some average temperature T_{surr} can be expressed as

$$\dot{Q}_{\text{rad}} = \varepsilon\sigma A_s(T_s^4 - T_{\text{surr}}^4) = h_{\text{rad}} A_s(T_s - T_{\text{surr}}) = \frac{T_s - T_{\text{surr}}}{R_{\text{rad}}} \quad (\text{W}) \quad (3-9)$$

where

$$R_{\text{rad}} = \frac{1}{h_{\text{rad}} A_s} \quad (\text{K}/\text{W}) \quad (3-10)$$

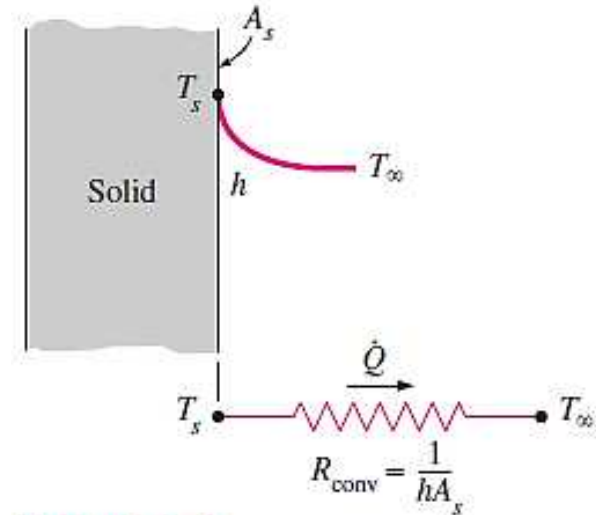

FIGURE 3–4

is the *thermal resistance* of a surface against radiation, or the *radiation resistance*, and

$$h_{\text{rad}} = \frac{\dot{Q}_{\text{rad}}}{A_s(T_s - T_{\text{surr}})} = \varepsilon\sigma(T_s^2 + T_{\text{surr}}^2)(T_s + T_{\text{surr}}) \quad (\text{W/m}^2 \cdot \text{K}) \quad (3-11)$$

is the **radiation heat transfer coefficient**. Note that both T_s and T_{surr} *must* be in K in the evaluation of h_{rad} . The definition of the radiation heat transfer coefficient enables us to express radiation conveniently in an analogous manner to convection in terms of a temperature difference. But h_{rad} depends strongly on temperature while h_{conv} usually does not.

A surface exposed to the surrounding air involves convection and radiation simultaneously, and the total heat transfer at the surface is determined by adding (or subtracting, if in the opposite direction) the radiation and convection components. The convection and radiation resistances are parallel to each other, as shown in Fig. 3–5, and may cause some complication in the thermal resistance network. When $T_{\text{surr}} \approx T_{\infty}$, the radiation effect can properly be accounted for by replacing h in the convection resistance relation by

$$h_{\text{combined}} = h_{\text{conv}} + h_{\text{rad}} \quad (\text{W/m}^2 \cdot \text{K}) \quad (3-12)$$

where h_{combined} is the **combined heat transfer coefficient**. This way all the complications associated with radiation are avoided.

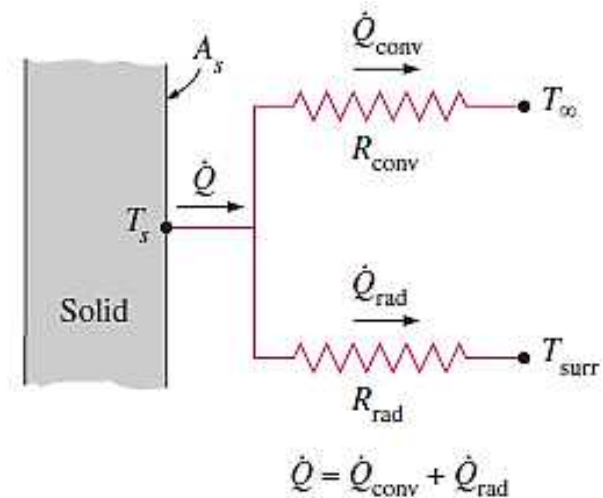

FIGURE 3–5

3-2 Thermal Resistance Network

$$\dot{Q} = h_1 A(T_{\infty 1} - T_1) = kA \frac{T_1 - T_2}{L} = h_2 A(T_2 - T_{\infty 2})$$

which can be rearranged as

$$\begin{aligned} \dot{Q} &= \frac{T_{\infty 1} - T_1}{1/h_1 A} = \frac{T_1 - T_2}{L/kA} = \frac{T_2 - T_{\infty 2}}{1/h_2 A} \\ &= \frac{T_{\infty 1} - T_1}{R_{\text{conv}, 1}} = \frac{T_1 - T_2}{R_{\text{wall}}} = \frac{T_2 - T_{\infty 2}}{R_{\text{conv}, 2}} \end{aligned}$$

Adding the numerators and denominators yields

$$\dot{Q} = \frac{T_{\infty 1} - T_{\infty 2}}{R_{\text{total}}} \quad (\text{W})$$

where

$$R_{\text{total}} = R_{\text{conv}, 1} + R_{\text{wall}} + R_{\text{conv}, 2} = \frac{1}{h_1 A} + \frac{L}{kA} + \frac{1}{h_2 A} \quad (^\circ\text{C/W})$$

It is sometimes convenient to express heat transfer through a medium in an analogous manner to Newton's law of cooling as

$$\dot{Q} = UA \Delta T = \frac{T_{\infty 1} - T_{\infty 2}}{R_{\text{total}}} \quad (\text{W})$$

where U is the overall heat transfer coefficient.

$$UA = \frac{1}{R_{\text{total}}}$$

Therefore, for a unit area, the overall heat transfer coefficient is equal to the inverse of the total thermal resistance.

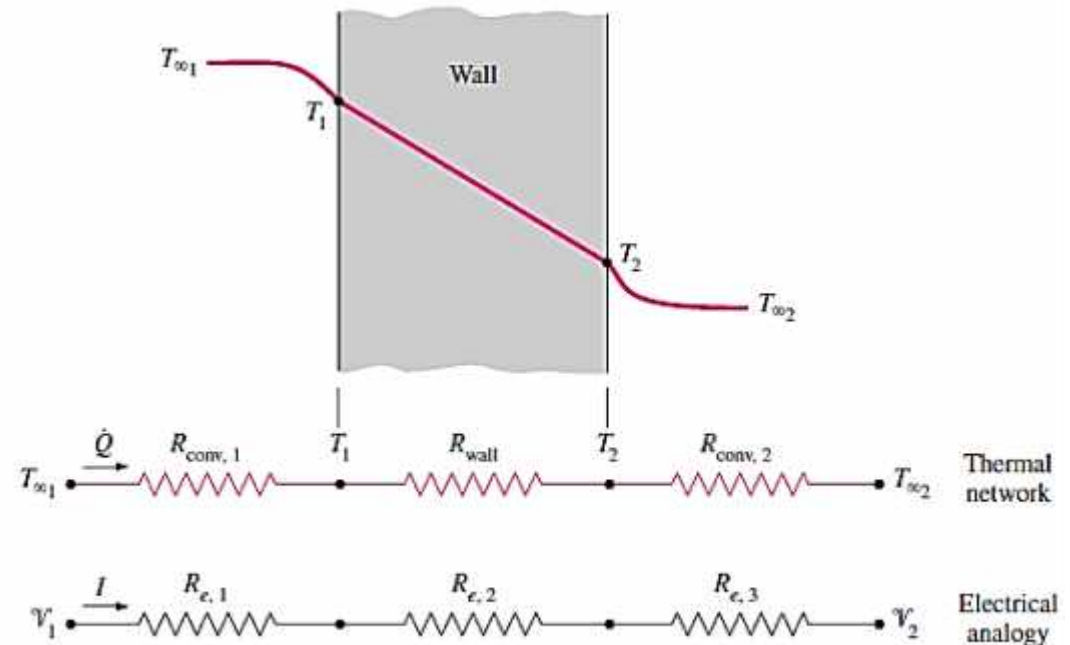

Multilayer Plane Walls

Consider a plane wall that consists of two layers (such as a brick wall with a layer of insulation). The rate of steady heat transfer through this two-layer composite wall can be expressed as

$$\dot{Q} = \frac{T_{\infty 1} - T_{\infty 2}}{R_{\text{total}}}$$

where R_{total} is the *total thermal resistance*, expressed as

$$R_{\text{total}} = R_{\text{conv},1} + R_{\text{wall},1} + R_{\text{wall},2} + R_{\text{conv},2}$$

$$= \frac{1}{h_1 A} + \frac{L_1}{k_1 A} + \frac{L_2}{k_2 A} + \frac{1}{h_2 A}$$

The subscripts 1 and 2 in the R_{wall} relations above indicate the first and the second layers, respectively.

To find T_1 :
$$\dot{Q} = \frac{T_{\infty 1} - T_1}{R_{\text{conv},1}}$$

To find T_2 :
$$\dot{Q} = \frac{T_{\infty 1} - T_2}{R_{\text{conv},1} + R_1}$$

To find T_3 :
$$\dot{Q} = \frac{T_3 - T_{\infty 2}}{R_{\text{conv},2}}$$

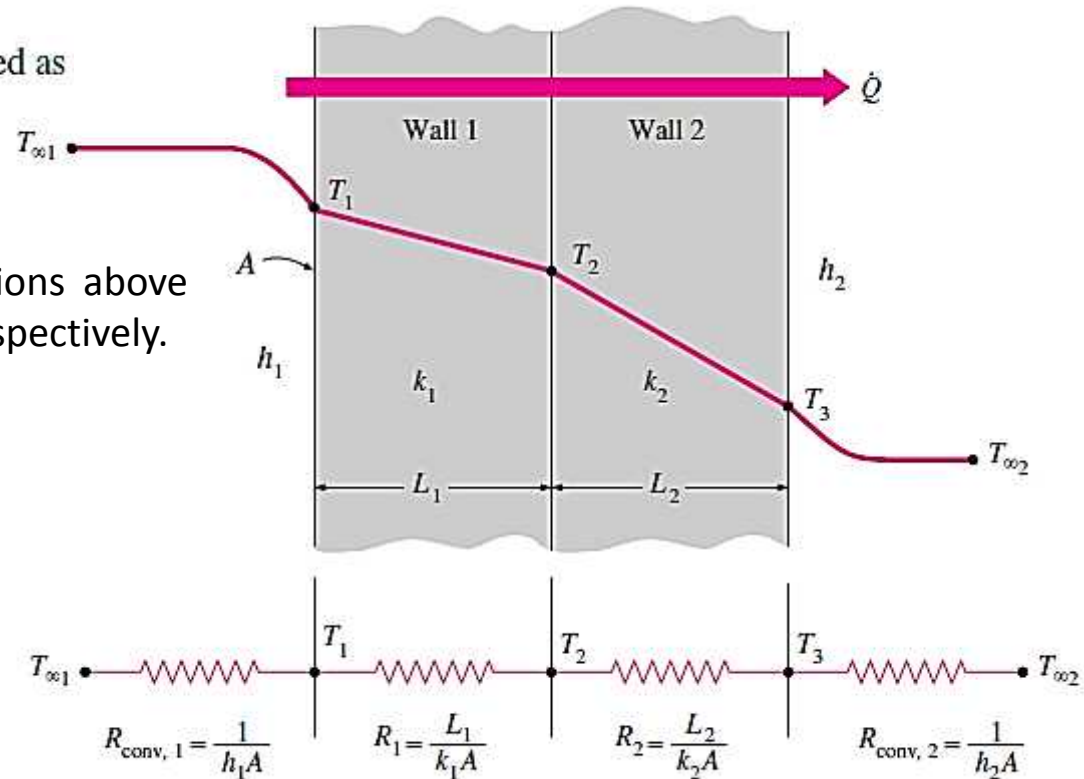

The interface temperature T_2 between the two walls can be determined from

$$\dot{Q} = \frac{T_{\infty 1} - T_2}{R_{\text{conv},1} + R_{\text{wall},1}} = \frac{T_{\infty 1} - T_2}{\frac{1}{h_1 A} + \frac{L_1}{k_1 A}}$$

EXAMPLE 3-1 Heat Loss through a Wall

Consider a 3-m-high, 5-m-wide, and 0.3-m-thick wall whose thermal conductivity is $k = 0.9 \text{ W/m} \cdot ^\circ\text{C}$ (Fig. 3-11). On a certain day, the temperatures of the inner and the outer surfaces of the wall are measured to be 16°C and 2°C , respectively. Determine the rate of heat loss through the wall on that day.

SOLUTION

Noting that the heat transfer through the wall is by conduction and the area of the wall is $A = 3 \text{ m} \times 5 \text{ m} = 15 \text{ m}^2$, the steady rate of heat transfer through the wall can be determined from

$$\dot{Q} = kA \frac{T_1 - T_2}{L} = (0.9 \text{ W/m} \cdot ^\circ\text{C})(15 \text{ m}^2) \frac{(16 - 2)^\circ\text{C}}{0.3 \text{ m}} = 630 \text{ W}$$

We could also determine the steady rate of heat transfer through the wall by making use of the thermal resistance concept from

$$\dot{Q} = \frac{\Delta T_{\text{wall}}}{R_{\text{wall}}}$$

where

$$R_{\text{wall}} = \frac{L}{kA} = \frac{0.3 \text{ m}}{(0.9 \text{ W/m} \cdot ^\circ\text{C})(15 \text{ m}^2)} = 0.02222^\circ\text{C/W}$$

Substituting, we get

$$\dot{Q} = \frac{(16 - 2)^\circ\text{C}}{0.02222^\circ\text{C/W}} = 630 \text{ W}$$

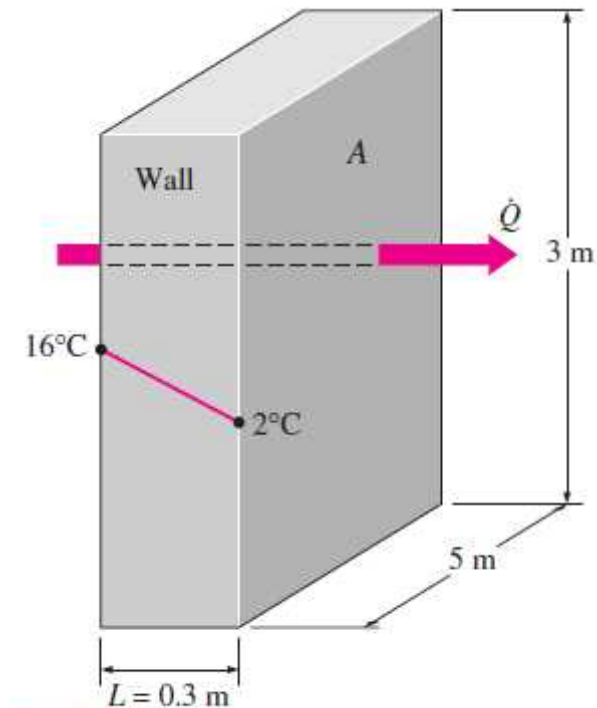

FIGURE 3-11

EXAMPLE 3-2 Heat Loss through a Single-Pane Window

Consider a 0.8-m-high and 1.5-m-wide glass window with a thickness of 8 mm and a thermal conductivity of $k = 0.78 \text{ W/m} \cdot ^\circ\text{C}$. Determine the steady rate of heat transfer through this glass window and the temperature of its inner surface for a day during which the room is maintained at 20°C while the temperature of the outdoors is -10°C . Take the heat transfer coefficients on the inner and outer surfaces of the window to be $h_1 = 10 \text{ W/m}^2 \cdot ^\circ\text{C}$ and $h_2 = 40 \text{ W/m}^2 \cdot ^\circ\text{C}$, which includes the effects of radiation.

SOLUTION

$$A = 0.8 \text{ m} \times 1.5 \text{ m} = 1.2 \text{ m}^2$$

$$R_i = R_{\text{conv},1} = \frac{1}{h_1 A} = \frac{1}{(10 \text{ W/m}^2 \cdot ^\circ\text{C})(1.2 \text{ m}^2)} = 0.08333^\circ\text{C/W}$$

$$R_{\text{glass}} = \frac{L}{kA} = \frac{0.008 \text{ m}}{(0.78 \text{ W/m} \cdot ^\circ\text{C})(1.2 \text{ m}^2)} = 0.00855^\circ\text{C/W}$$

$$R_o = R_{\text{conv},2} = \frac{1}{h_2 A} = \frac{1}{(40 \text{ W/m}^2 \cdot ^\circ\text{C})(1.2 \text{ m}^2)} = 0.02083^\circ\text{C/W}$$

Noting that all three resistances are in series, the total resistance is

$$\begin{aligned} R_{\text{total}} &= R_{\text{conv},1} + R_{\text{glass}} + R_{\text{conv},2} = 0.08333 + 0.00855 + 0.02083 \\ &= 0.1127^\circ\text{C/W} \end{aligned}$$

Then the steady rate of heat transfer through the window becomes

$$\dot{Q} = \frac{T_{\infty 1} - T_{\infty 2}}{R_{\text{total}}} = \frac{[20 - (-10)]^\circ\text{C}}{0.1127^\circ\text{C/W}} = 266 \text{ W}$$

Knowing the rate of heat transfer, the inner surface temperature of the window glass can be determined from

$$\begin{aligned} \dot{Q} &= \frac{T_{\infty 1} - T_1}{R_{\text{conv},1}} \quad \longrightarrow \quad T_1 = T_{\infty 1} - \dot{Q} R_{\text{conv},1} \\ &= 20^\circ\text{C} - (266 \text{ W})(0.08333^\circ\text{C/W}) \\ &= -2.2^\circ\text{C} \end{aligned}$$

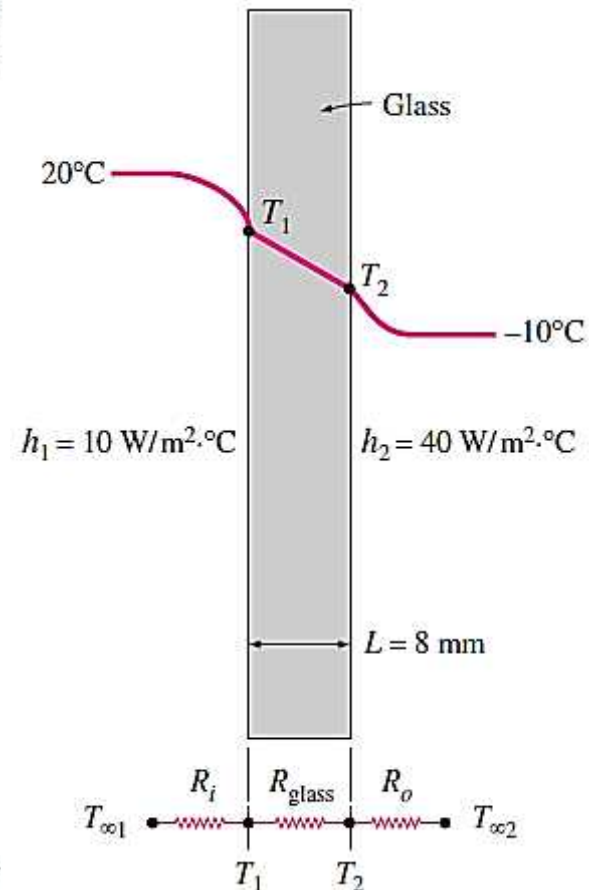

EXAMPLE 3-3 Heat Loss through Double-Pane Windows

Consider a 0.8-m-high and 1.5-m-wide double-pane window consisting of two 4-mm-thick layers of glass ($k = 0.78 \text{ W/m} \cdot ^\circ\text{C}$) separated by a 10-mm-wide stagnant air space ($k = 0.026 \text{ W/m} \cdot ^\circ\text{C}$). Determine the steady rate of heat transfer through this double-pane window and the temperature of its inner surface for a day during which the room is maintained at 20°C while the temperature of the outdoors is -10°C . Take the convection heat transfer coefficients on the inner and outer surfaces of the window to be $h_1 = 10 \text{ W/m}^2 \cdot ^\circ\text{C}$ and $h_2 = 40 \text{ W/m}^2 \cdot ^\circ\text{C}$, which includes the effects of radiation.

SOLUTION

$$A = 0.8 \text{ m} \times 1.5 \text{ m} = 1.2 \text{ m}^2,$$

$$R_i = R_{\text{conv},1} = \frac{1}{h_1 A} = \frac{1}{(10 \text{ W/m}^2 \cdot ^\circ\text{C})(1.2 \text{ m}^2)} = 0.08333^\circ\text{C/W}$$

$$R_1 = R_3 = R_{\text{glass}} = \frac{L_1}{k_1 A} = \frac{0.004 \text{ m}}{(0.78 \text{ W/m} \cdot ^\circ\text{C})(1.2 \text{ m}^2)} = 0.00427^\circ\text{C/W}$$

$$R_2 = R_{\text{air}} = \frac{L_2}{k_2 A} = \frac{0.01 \text{ m}}{(0.026 \text{ W/m} \cdot ^\circ\text{C})(1.2 \text{ m}^2)} = 0.3205^\circ\text{C/W}$$

$$R_o = R_{\text{conv},2} = \frac{1}{h_2 A} = \frac{1}{(40 \text{ W/m}^2 \cdot ^\circ\text{C})(1.2 \text{ m}^2)} = 0.02083^\circ\text{C/W}$$

Noting that all three resistances are in series, the total resistance is

$$\begin{aligned} R_{\text{total}} &= R_{\text{conv},1} + R_{\text{glass},1} + R_{\text{air}} + R_{\text{glass},2} + R_{\text{conv},2} \\ &= 0.08333 + 0.00427 + 0.3205 + 0.00427 + 0.02083 \\ &= 0.4332^\circ\text{C/W} \end{aligned}$$

Then the steady rate of heat transfer through the window becomes

$$\dot{Q} = \frac{T_{\infty 1} - T_{\infty 2}}{R_{\text{total}}} = \frac{[20 - (-10)]^\circ\text{C}}{0.4332^\circ\text{C/W}} = 69.2 \text{ W}$$

The inner surface temperature of the window in this case will be

$$T_1 = T_{\infty 1} - \dot{Q} R_{\text{conv},1} = 20^\circ\text{C} - (69.2 \text{ W})(0.08333^\circ\text{C/W}) = 14.2^\circ\text{C}$$

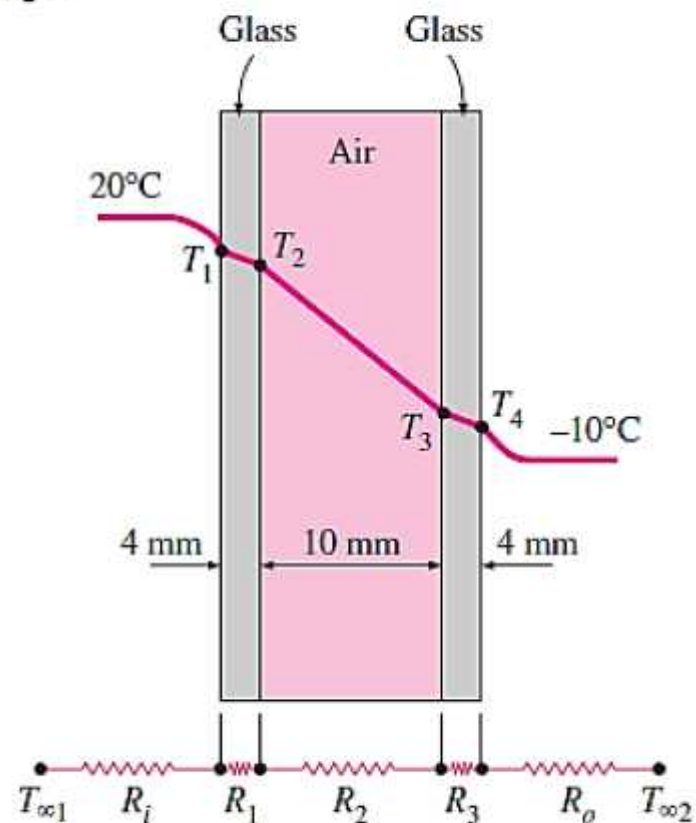

3-3 GENERALIZED THERMAL RESISTANCE NETWORKS

The *thermal resistance* concept or the *electrical analogy* can also be used to solve steady heat transfer problems that involve parallel layers or combined series-parallel arrangements. Although such problems are often two- or even three-dimensional, approximate solutions can be obtained by assuming one-dimensional heat transfer and using the thermal resistance network.

Consider the composite wall shown in Fig. 3-19, which consists of two parallel layers. The thermal resistance network, which consists of two parallel resistances, can be represented as shown in the figure. Noting that the total heat transfer is the sum of the heat transfers through each layer, we have

$$\dot{Q} = \dot{Q}_1 + \dot{Q}_2 = \frac{T_1 - T_2}{R_1} + \frac{T_1 - T_2}{R_2} = (T_1 - T_2) \left(\frac{1}{R_1} + \frac{1}{R_2} \right)$$

Utilizing electrical analogy, we get

$$\dot{Q} = \frac{T_1 - T_2}{R_{\text{total}}}$$

where

$$\frac{1}{R_{\text{total}}} = \frac{1}{R_1} + \frac{1}{R_2} \longrightarrow R_{\text{total}} = \frac{R_1 R_2}{R_1 + R_2}$$

since the resistances are in parallel.

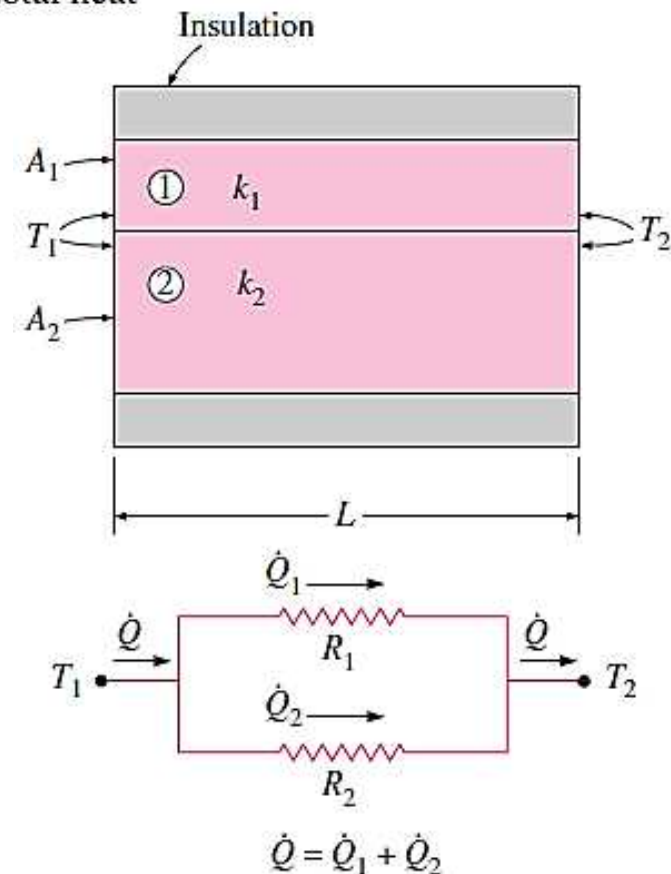

FIGURE 3-19

Now consider the combined series-parallel arrangement shown in Fig. 3–20. The total rate of heat transfer through this composite system can again be expressed as

$$\dot{Q} = \frac{T_1 - T_\infty}{R_{\text{total}}} \quad \text{where}$$

$$R_{\text{total}} = R_{12} + R_3 + R_{\text{conv}} = \frac{R_1 R_2}{R_1 + R_2} + R_3 + R_{\text{conv}}$$

and

$$R_1 = \frac{L_1}{k_1 A_1}, \quad R_2 = \frac{L_2}{k_2 A_2}, \quad R_3 = \frac{L_3}{k_3 A_3}, \quad R_{\text{conv}} = \frac{1}{h A_3}$$

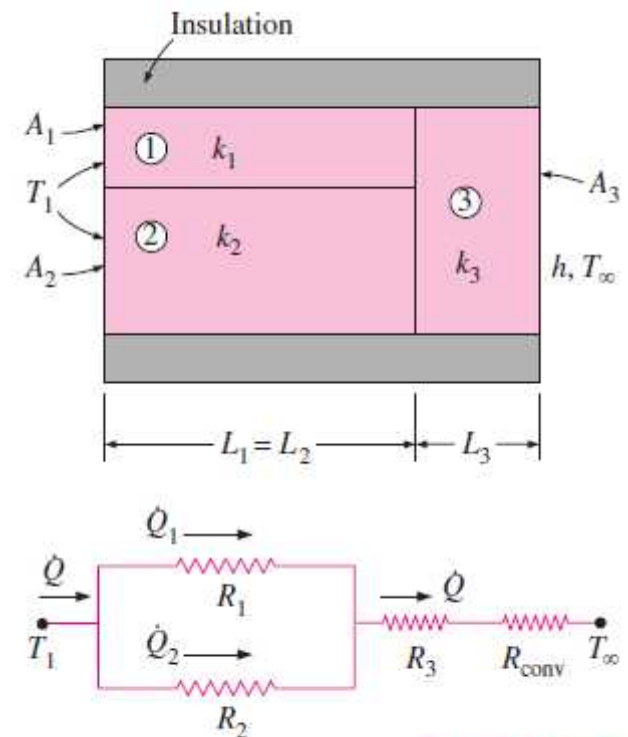

FIGURE 3–20

EXAMPLE 3-4 Heat Loss through a Composite Wall

A 3-m-high and 5-m-wide wall consists of long 16-cm \times 22-cm cross section horizontal bricks ($k = 0.72 \text{ W/m} \cdot ^\circ\text{C}$) separated by 3-cm-thick plaster layers ($k = 0.22 \text{ W/m} \cdot ^\circ\text{C}$). There are also 2-cm-thick plaster layers on each side of the brick and a 3-cm-thick rigid foam ($k = 0.026 \text{ W/m} \cdot ^\circ\text{C}$) on the inner side of the wall, as shown in Fig. 3–21. The indoor and the outdoor temperatures are 20°C and -10°C , and the convection heat transfer coefficients on the inner and the outer sides are $h_1 = 10 \text{ W/m}^2 \cdot ^\circ\text{C}$ and $h_2 = 25 \text{ W/m}^2 \cdot ^\circ\text{C}$, respectively. Assuming one-dimensional heat transfer and disregarding radiation, determine the rate of heat transfer through the wall.

SOLUTION

$$R_i = R_{\text{conv},1} = \frac{1}{h_1 A} = \frac{1}{(10 \text{ W/m}^2 \cdot ^\circ\text{C})(0.25 \times 1 \text{ m}^2)} = 0.4^\circ\text{C/W}$$

$$R_1 = R_{\text{foam}} = \frac{L}{kA} = \frac{0.03 \text{ m}}{(0.026 \text{ W/m} \cdot ^\circ\text{C})(0.25 \times 1 \text{ m}^2)} = 4.6^\circ\text{C/W}$$

$$R_2 = R_6 = R_{\text{plaster, side}} = \frac{L}{kA} = \frac{0.02 \text{ m}}{(0.22 \text{ W/m} \cdot ^\circ\text{C})(0.25 \times 1 \text{ m}^2)} = 0.36^\circ\text{C/W}$$

$$R_3 = R_5 = R_{\text{plaster, center}} = \frac{L}{kA} = \frac{0.16 \text{ m}}{(0.22 \text{ W/m} \cdot ^\circ\text{C})(0.015 \times 1 \text{ m}^2)} = 48.48^\circ\text{C/W}$$

$$R_4 = R_{\text{brick}} = \frac{L}{kA} = \frac{0.16 \text{ m}}{(0.72 \text{ W/m} \cdot ^\circ\text{C})(0.22 \times 1 \text{ m}^2)} = 1.01^\circ\text{C/W}$$

$$R_o = R_{\text{conv},2} = \frac{1}{h_2 A} = \frac{1}{(25 \text{ W/m}^2 \cdot ^\circ\text{C})(0.25 \times 1 \text{ m}^2)} = 0.16^\circ\text{C/W}$$

The three resistances R_3 , R_4 , and R_5 in the middle are parallel, and their equivalent resistance is determined from

$$\frac{1}{R_{\text{mid}}} = \frac{1}{R_3} + \frac{1}{R_4} + \frac{1}{R_5} = \frac{1}{48.48} + \frac{1}{1.01} + \frac{1}{48.48} = 1.03 \text{ W/}^\circ\text{C}$$

which gives

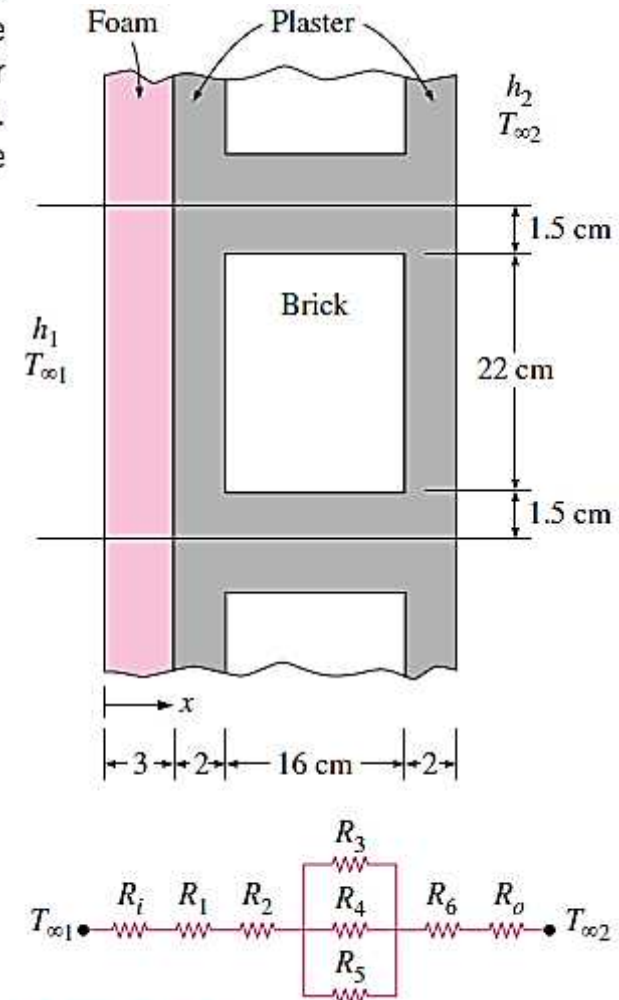

FIGURE 3-21

$$R_{\text{mid}} = 0.97^\circ\text{C}/\text{W}$$

Now all the resistances are in series, and the total resistance is

$$\begin{aligned} R_{\text{total}} &= R_i + R_1 + R_2 + R_{\text{mid}} + R_6 + R_o \\ &= 0.4 + 4.6 + 0.36 + 0.97 + 0.36 + 0.16 \\ &= 6.85^\circ\text{C}/\text{W} \end{aligned}$$

Then the steady rate of heat transfer through the wall becomes

$$\dot{Q} = \frac{T_{\infty 1} - T_{\infty 2}}{R_{\text{total}}} = \frac{[20 - (-10)]^\circ\text{C}}{6.85^\circ\text{C}/\text{W}} = 4.38 \text{ W} \quad (\text{per } 0.25 \text{ m}^2 \text{ surface area})$$

or $4.38/0.25 = 17.5 \text{ W per m}^2$ area. The total area of the wall is $A = 3 \text{ m} \times 5 \text{ m} = 15 \text{ m}^2$. Then the rate of heat transfer through the entire wall becomes

$$\dot{Q}_{\text{total}} = (17.5 \text{ W/m}^2)(15 \text{ m}^2) = \mathbf{263 \text{ W}}$$

3–4 HEAT CONDUCTION IN CYLINDERS AND SPHERES

Consider steady heat conduction through a hot water pipe. Heat is continuously lost to the outdoors through the wall of the pipe, and we intuitively feel that heat transfer through the pipe is in the normal direction to the pipe surface and no significant heat transfer takes place in the pipe in other directions (Fig. 3–23). The wall of the pipe, whose thickness is rather small, separates two fluids at different temperatures, and thus the temperature gradient in the radial direction will be relatively large. Further, if the fluid temperatures inside and outside the pipe remain constant, then heat transfer through the pipe is *steady*. Thus heat transfer through the pipe can be modeled as *steady* and *one-dimensional*. The temperature of the pipe in this case will depend on one direction only (the radial r -direction) and can be expressed as $T = T(r)$. The temperature is independent of the azimuthal angle or the axial distance. This situation is approximated in practice in long cylindrical pipes and spherical containers.

In *steady* operation, there is no change in the temperature of the pipe with time at any point. Therefore, the rate of heat transfer into the pipe must be equal to the rate of heat transfer out of it. In other words, heat transfer through the pipe must be constant, $\dot{Q}_{\text{cond, cyl}} = \text{constant}$.

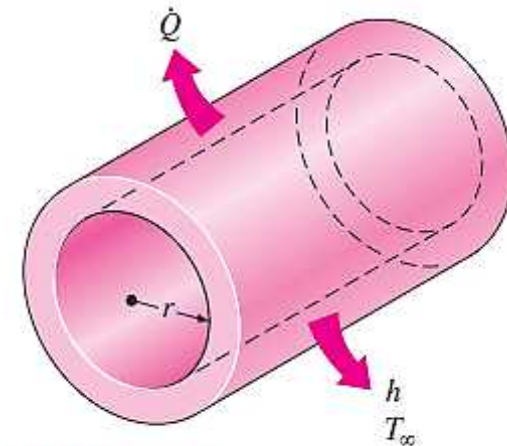

FIGURE 3–23

Consider a long cylindrical layer (such as a circular pipe) of inner radius r_1 , outer radius r_2 , length L , and average thermal conductivity k (Fig. 3–24). The two surfaces of the cylindrical layer are maintained at constant temperatures T_1 and T_2 . There is no heat generation in the layer and the thermal conductivity is constant. For one-dimensional heat conduction through the cylindrical layer, we have $T(r)$. Then Fourier's law of heat conduction for heat transfer through the cylindrical layer can be expressed as

$$\dot{Q}_{\text{cond, cyl}} = -kA \frac{dT}{dr} \quad (\text{W})$$

where $A = 2\pi rL$ is the heat transfer area at location r . Note that A depends on r , and thus it *varies* in the direction of heat transfer. Separating the variables in the above equation and integrating from $r = r_1$, where $T(r_1) = T_1$, to $r = r_2$, where $T(r_2) = T_2$, gives

$$\int_{r=r_1}^{r_2} \frac{\dot{Q}_{\text{cond, cyl}}}{A} dr = - \int_{T=T_1}^{T_2} k dT \quad (3-36)$$

Substituting $A = 2\pi rL$ and performing the integrations give

$$\dot{Q}_{\text{cond, cyl}} = 2\pi Lk \frac{T_1 - T_2}{\ln(r_2/r_1)} \quad (\text{W})$$

since $\dot{Q}_{\text{cond, cyl}} = \text{constant}$. This equation can be rearranged as

$$\dot{Q}_{\text{cond, cyl}} = \frac{T_1 - T_2}{R_{\text{cyl}}} \quad (\text{W})$$

$$R_{\text{cyl}} = \frac{\ln(r_2/r_1)}{2\pi Lk} = \frac{\ln(\text{Outer radius/Inner radius})}{2\pi \times (\text{Length}) \times (\text{Thermal conductivity})}$$

is the *thermal resistance* of the cylindrical layer against heat conduction, or simply the **conduction resistance** of the cylinder layer.

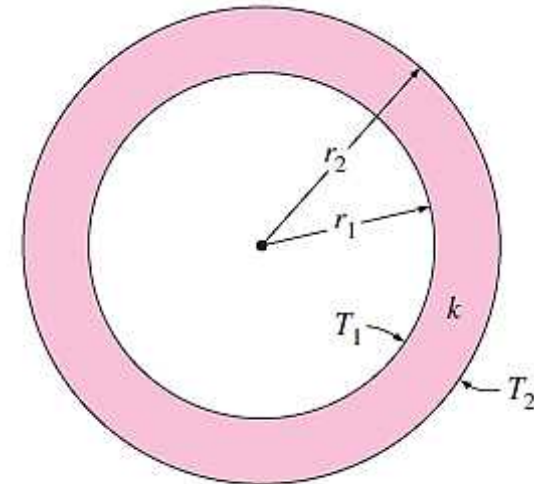

FIGURE 3–24

We can repeat the analysis above for a *spherical layer* by taking $A = 4\pi r^2$ and performing the integrations in Eq. 3–36. The result can be expressed as

$$\dot{Q}_{\text{cond, sph}} = \frac{T_1 - T_2}{R_{\text{sph}}} \quad \text{where}$$

$$R_{\text{sph}} = \frac{r_2 - r_1}{4\pi r_1 r_2 k} = \frac{\text{Outer radius} - \text{Inner radius}}{4\pi(\text{Outer radius})(\text{Inner radius})(\text{Thermal conductivity})}$$

is the *thermal resistance* of the spherical layer against heat conduction, or simply the **conduction resistance** of the spherical layer.

Now consider steady one-dimensional heat flow through a cylindrical or spherical layer that is exposed to convection on both sides to fluids at temperatures $T_{\infty 1}$ and $T_{\infty 2}$ with heat transfer coefficients h_1 and h_2 , respectively, as shown in Fig. 3–25. The thermal resistance network in this case consists of one conduction and two convection resistances in series, just like the one for the plane wall, and the rate of heat transfer under steady conditions can be expressed as

$$\dot{Q} = \frac{T_{\infty 1} - T_{\infty 2}}{R_{\text{total}}} \quad \text{where}$$

$$R_{\text{total}} = R_{\text{conv, 1}} + R_{\text{cyl}} + R_{\text{conv, 2}}$$

$$= \frac{1}{(2\pi r_1 L)h_1} + \frac{\ln(r_2/r_1)}{2\pi Lk} + \frac{1}{(2\pi r_2 L)h_2}$$

for a *cylindrical* layer, and

$$R_{\text{total}} = R_{\text{conv, 1}} + R_{\text{sph}} + R_{\text{conv, 2}}$$

$$= \frac{1}{(4\pi r_1^2)h_1} + \frac{r_2 - r_1}{4\pi r_1 r_2 k} + \frac{1}{(4\pi r_2^2)h_2}$$

for a *spherical* layer. Note that A in the convection resistance relation $R_{\text{conv}} = 1/hA$ is the *surface area at which convection occurs*. It is equal to $A = 2\pi rL$ for a cylindrical surface and $A = 4\pi r^2$ for a spherical surface of radius r .

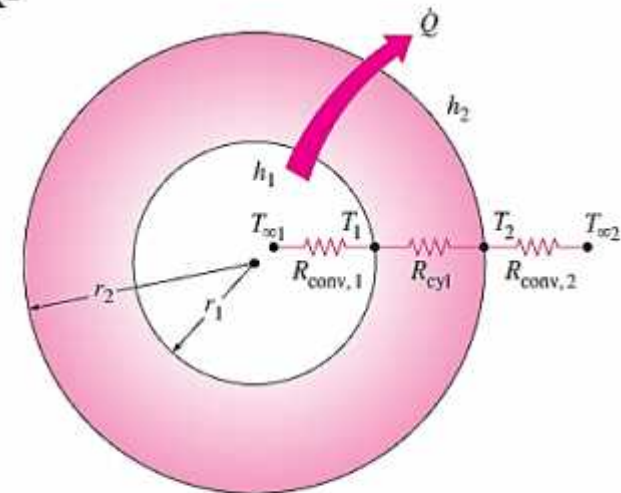

$$R_{\text{total}} = R_{\text{conv, 1}} + R_{\text{cyl}} + R_{\text{conv, 2}}$$

Multilayered Cylinders and Spheres

Steady heat transfer through multilayered cylindrical or spherical shells can be handled just like multilayered plane walls discussed earlier by simply adding an *additional resistance* in series for each *additional layer*. For example, the steady heat transfer rate through the three-layered composite cylinder of length L shown in Fig. 3–26 with convection on bc pressed as

$$\dot{Q} = \frac{T_{\infty 1} - T_{\infty 2}}{R_{\text{total}}}$$

where R_{total} is the *total thermal resistance*, expressed as

$$\begin{aligned} R_{\text{total}} &= R_{\text{conv},1} + R_{\text{cyl},1} + R_{\text{cyl},2} + R_{\text{cyl},3} + R_{\text{conv},2} \\ &= \frac{1}{h_1 A_1} + \frac{\ln(r_2/r_1)}{2\pi L k_1} + \frac{\ln(r_3/r_2)}{2\pi L k_2} + \frac{\ln(r_4/r_3)}{2\pi L k_3} + \frac{1}{h_2 A_4} \end{aligned} \quad (3-46)$$

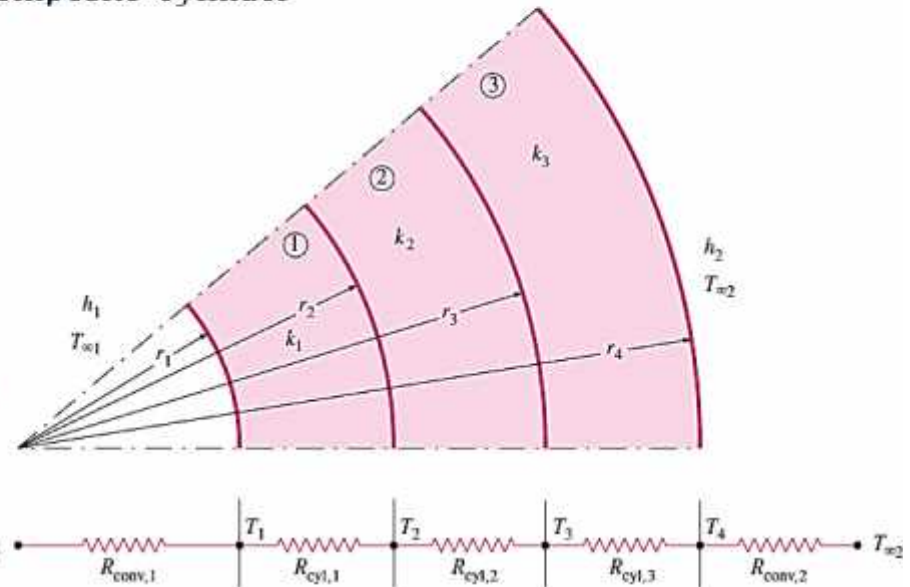

FIGURE 3–26

where $A_1 = 2\pi r_1 L$ and $A_4 = 2\pi r_4 L$. Equation 3–46 can also be used for a three-layered spherical shell by replacing the thermal resistances of cylindrical layers by the corresponding spherical ones. Again, note from the thermal resistance network that the resistances are in series, and thus the total thermal resistance is simply the *arithmetic sum* of the individual thermal resistances in the path of heat flow.

We could also calculate T_2 from

$$\dot{Q} = \frac{T_2 - T_{\infty 2}}{R_2 + R_3 + R_{\text{conv},2}} = \frac{T_2 - T_{\infty 2}}{\frac{\ln(r_3/r_2)}{2\pi L k_2} + \frac{\ln(r_4/r_3)}{2\pi L k_3} + \frac{1}{h_o(2\pi r_4 L)}}$$

EXAMPLE 3–5 Heat Loss through an Insulated Steam Pipe

Steam at $T_{\infty 1} = 320^\circ\text{C}$ flows in a cast iron pipe ($k = 80 \text{ W/m} \cdot ^\circ\text{C}$) whose inner and outer diameters are $D_1 = 5 \text{ cm}$ and $D_2 = 5.5 \text{ cm}$, respectively. The pipe is covered with 3-cm-thick glass wool insulation with $k = 0.05 \text{ W/m} \cdot ^\circ\text{C}$. Heat is lost to the surroundings at $T_{\infty 2} = 5^\circ\text{C}$ by natural convection and radiation, with a combined heat transfer coefficient of $h_2 = 18 \text{ W/m}^2 \cdot ^\circ\text{C}$. Taking the heat transfer coefficient inside the pipe to be $h_1 = 60 \text{ W/m}^2 \cdot ^\circ\text{C}$, determine the rate of heat loss from the steam per unit length of the pipe. Also determine the temperature drops across the pipe shell and the insulation.

SOLUTION

Taking $L = 1 \text{ m}$

$$A_1 = 2\pi r_1 L = 2\pi(0.025 \text{ m})(1 \text{ m}) = 0.157 \text{ m}^2$$

$$A_3 = 2\pi r_3 L = 2\pi(0.0575 \text{ m})(1 \text{ m}) = 0.361 \text{ m}^2$$

Then the individual thermal resistances become

$$R_i = R_{\text{conv}, 1} = \frac{1}{h_1 A} = \frac{1}{(60 \text{ W/m}^2 \cdot ^\circ\text{C})(0.157 \text{ m}^2)} = 0.106^\circ\text{C/W}$$

$$R_1 = R_{\text{pipe}} = \frac{\ln(r_2/r_1)}{2\pi k_1 L} = \frac{\ln(2.75/2.5)}{2\pi(80 \text{ W/m} \cdot ^\circ\text{C})(1 \text{ m})} = 0.0002^\circ\text{C/W}$$

$$R_2 = R_{\text{insulation}} = \frac{\ln(r_3/r_2)}{2\pi k_2 L} = \frac{\ln(5.75/2.75)}{2\pi(0.05 \text{ W/m} \cdot ^\circ\text{C})(1 \text{ m})} = 2.35^\circ\text{C/W}$$

$$R_o = R_{\text{conv}, 2} = \frac{1}{h_2 A_3} = \frac{1}{(18 \text{ W/m}^2 \cdot ^\circ\text{C})(0.361 \text{ m}^2)} = 0.154^\circ\text{C/W}$$

Noting that all resistances are in series, the total resistance is determined to be $R_{\text{total}} = R_i + R_1 + R_2 + R_o = 0.106 + 0.0002 + 2.35 + 0.154 = 2.61^\circ\text{C/W}$

Then the steady rate of heat loss from the steam becomes

$$\dot{Q} = \frac{T_{\infty 1} - T_{\infty 2}}{R_{\text{total}}} = \frac{(320 - 5)^\circ\text{C}}{2.61^\circ\text{C/W}} = \mathbf{121 \text{ W}} \quad (\text{per m pipe length})$$

$$\Delta T_{\text{pipe}} = \dot{Q} R_{\text{pipe}} = (121 \text{ W})(0.0002^\circ\text{C/W}) = \mathbf{0.02^\circ\text{C}}$$

$$\Delta T_{\text{insulation}} = \dot{Q} R_{\text{insulation}} = (121 \text{ W})(2.35^\circ\text{C/W}) = \mathbf{284^\circ\text{C}}$$

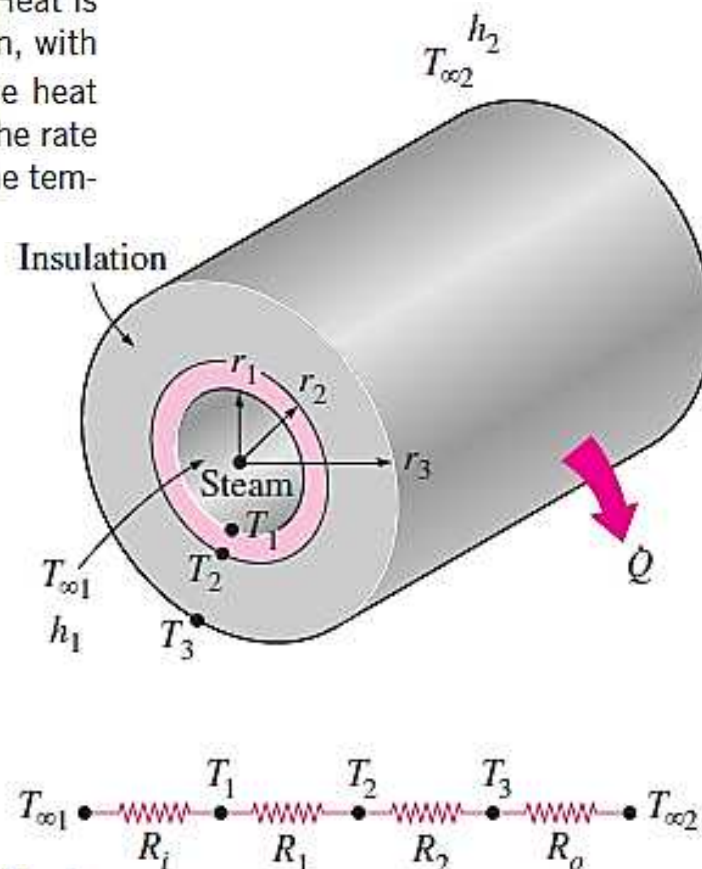

3–5 CRITICAL RADIUS OF INSULATION

We know that adding more insulation to a wall or to the attic always decreases heat transfer. The thicker the insulation, the lower the heat transfer rate. This is expected, since the heat transfer area A is constant, and adding insulation always increases the thermal resistance of the wall without increasing the convection resistance.

Adding insulation to a cylindrical pipe or a spherical shell, however, is a different matter. The additional insulation increases the conduction resistance of the insulation layer but decreases the convection resistance of the surface because of the increase in the outer surface area for convection. The heat transfer from the pipe may increase or decrease, depending on which effect dominates.

Consider a cylindrical pipe of outer radius r_1 whose outer surface temperature T_1 is maintained constant (Fig. 3–30). The pipe is now insulated with a material whose thermal conductivity is k and outer radius is r_2 . Heat is lost from the pipe to the surrounding medium at temperature T_∞ , with a convection heat transfer coefficient h . The rate of heat transfer from the insulated pipe to the surrounding air can be expressed as (Fig. 3–31)

$$\dot{Q} = \frac{T_1 - T_\infty}{R_{\text{ins}} + R_{\text{conv}}} = \frac{T_1 - T_\infty}{\frac{\ln(r_2/r_1)}{2\pi Lk} + \frac{1}{h(2\pi r_2 L)}}$$

The variation of \dot{Q} with the outer radius of the insulation r_2 is plotted in Fig. 3–31. The value of r_2 at which \dot{Q} reaches a maximum is determined from the requirement that $d\dot{Q}/dr_2 = 0$ (zero slope). Performing the differentiation and solving for r_2 yields the **critical radius of insulation** for a cylindrical body to be

$$r_{\text{cr, cylinder}} = \frac{k}{h} \quad (\text{m})$$

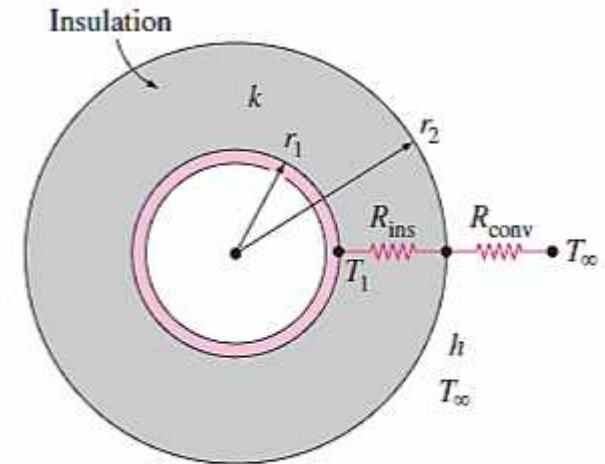

FIGURE 3–30

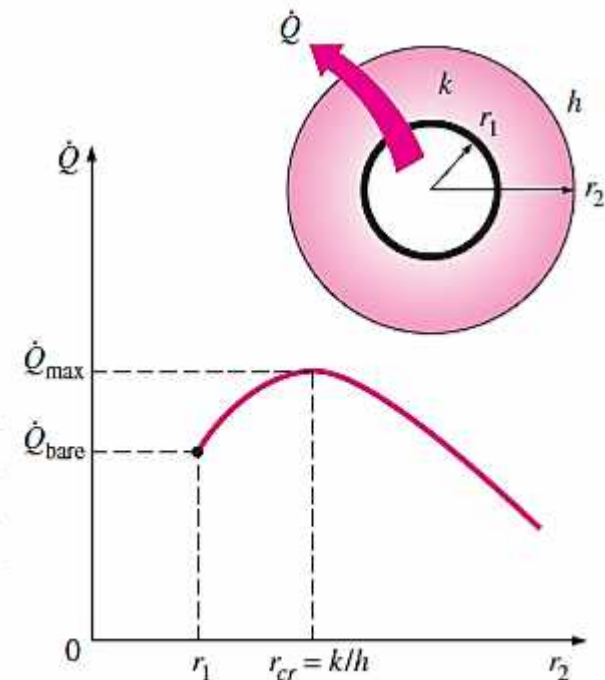

FIGURE 3–31

Note that the critical radius of insulation depends on the thermal conductivity of the insulation k and the external convection heat transfer coefficient h . The rate of heat transfer from the cylinder increases with the addition of insulation for $r_2 < r_{cr}$, reaches a maximum when $r_2 = r_{cr}$, and starts to decrease for $r_2 > r_{cr}$. Thus, insulating the pipe may actually increase the rate of heat transfer from the pipe instead of decreasing it when $r_2 < r_{cr}$.

The important question to answer at this point is whether we need to be concerned about the critical radius of insulation when insulating hot water pipes or even hot water tanks. Should we always check and make sure that the outer radius of insulation exceeds the critical radius before we install any insulation? Probably not, as explained here.

The value of the critical radius r_{cr} will be the largest when k is large and h is small. Noting that the lowest value of h encountered in practice is about $5 \text{ W/m}^2 \cdot ^\circ\text{C}$ for the case of natural convection of gases, and that the thermal conductivity of common insulating materials is about $0.05 \text{ W/m} \cdot ^\circ\text{C}$, the largest value of the critical radius we are likely to encounter is

$$r_{cr, \max} = \frac{k_{\max, \text{insulation}}}{h_{\min}} \approx \frac{0.05 \text{ W/m} \cdot ^\circ\text{C}}{5 \text{ W/m}^2 \cdot ^\circ\text{C}} = 0.01 \text{ m} = 1 \text{ cm}$$

This value would be even smaller when the radiation effects are considered. The critical radius would be much less in forced convection, often less than 1 mm, because of much larger h values associated with forced convection. Therefore, we can insulate hot water or steam pipes freely without worrying about the possibility of increasing the heat transfer by insulating the pipes.

The discussions above can be repeated for a sphere, and it can be shown in a similar manner that the critical radius of insulation for a spherical shell is

$$r_{cr, \text{sphere}} = \frac{2k}{h}$$

where k is the thermal conductivity of the insulation and h is the convection heat transfer coefficient on the outer surface.

EXAMPLE 3–6 Heat Loss from an Insulated Electric Wire

A 3-mm-diameter and 5-m-long electric wire is tightly wrapped with a 2-mm-thick plastic cover whose thermal conductivity is $k = 0.15 \text{ W/m} \cdot ^\circ\text{C}$. Electrical measurements indicate that a current of 10 A passes through the wire and there is a voltage drop of 8 V along the wire. If the insulated wire is exposed to a medium at $T_\infty = 30^\circ\text{C}$ with a heat transfer coefficient of $h = 12 \text{ W/m}^2 \cdot ^\circ\text{C}$, determine the temperature at the interface of the wire and the plastic cover in steady operation. Also determine whether doubling the thickness of the plastic cover will increase or decrease this interface temperature.

SOLUTION

The rate of heat transfer becomes equal to the heat generated within the wire, which is determined to be

$$\dot{Q} = \dot{W}_e = VI = (8 \text{ V})(10 \text{ A}) = 80 \text{ W}$$

The values of these two resistances are determined to be

$$A_2 = (2\pi r_2)L = 2\pi(0.0035 \text{ m})(5 \text{ m}) = 0.110 \text{ m}^2$$

$$R_{\text{conv}} = \frac{1}{hA_2} = \frac{1}{(12 \text{ W/m}^2 \cdot ^\circ\text{C})(0.110 \text{ m}^2)} = 0.76^\circ\text{C/W}$$

$$R_{\text{plastic}} = \frac{\ln(r_2/r_1)}{2\pi kL} = \frac{\ln(3.5/1.5)}{2\pi(0.15 \text{ W/m} \cdot ^\circ\text{C})(5 \text{ m})} = 0.18^\circ\text{C/W}$$

and therefore

$$R_{\text{total}} = R_{\text{plastic}} + R_{\text{conv}} = 0.76 + 0.18 = 0.94^\circ\text{C/W}$$

Then the interface temperature can be determined from

$$\dot{Q} = \frac{T_1 - T_\infty}{R_{\text{total}}} \quad \longrightarrow \quad T_1 = T_\infty + \dot{Q}R_{\text{total}} \\ = 30^\circ\text{C} + (80 \text{ W})(0.94^\circ\text{C/W}) = 105^\circ\text{C}$$

To answer the second part of the question, we need to know the critical radius of insulation of the plastic cover

$$r_{\text{cr}} = \frac{k}{h} = \frac{0.15 \text{ W/m} \cdot ^\circ\text{C}}{12 \text{ W/m}^2 \cdot ^\circ\text{C}} = 0.0125 \text{ m} = 12.5 \text{ mm}$$

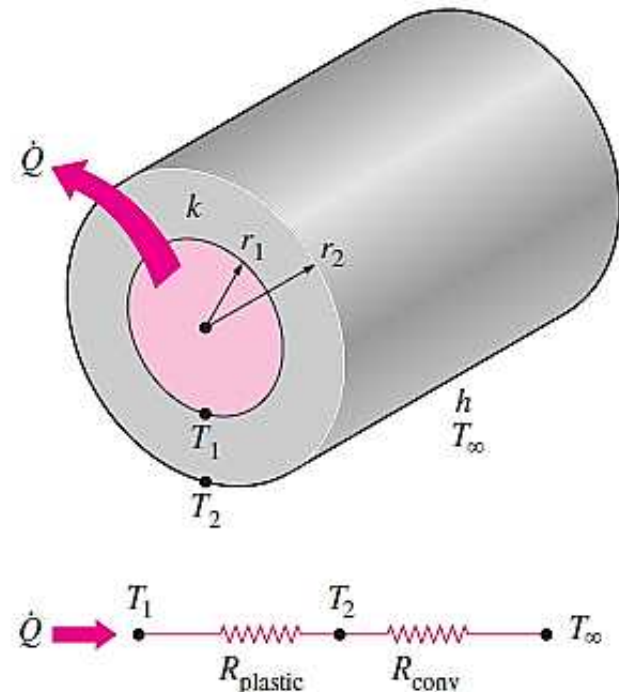

which is larger than the radius of the plastic cover. Therefore, increasing the thickness of the plastic cover will *enhance* heat transfer until the outer radius of the cover reaches 12.5 mm. As a result, the rate of heat transfer \dot{Q} will *increase* when the interface temperature T_1 is held constant, or T_1 will *decrease* when \dot{Q} is held constant, which is the case here.

Discussion It can be shown by repeating the calculations above for a 4-mm-thick plastic cover that the interface temperature drops to 90.6°C when the thickness of the plastic cover is doubled. It can also be shown in a similar manner that the interface reaches a minimum temperature of 83°C when the outer radius of the plastic cover equals the critical radius.

Problems Group A

3.1 Consider a slab of thickness 10cm. One surface is kept at 20°C and the other at 100°C . Determine the heat flow rate across the slab if the slab is made of pure copper [$k=387\text{W/m}\cdot^{\circ}\text{C}$], pure aluminum [$k=202\text{W/m}\cdot^{\circ}\text{C}$], and pure iron [$k=62\text{W/m}\cdot^{\circ}\text{C}$].

3.2 A brick wall [$k=0.69\text{W/m}\cdot^{\circ}\text{C}$] 5cm thick is exposed to cool air at 10°C with a heat transfer coefficient of $10\text{W/m}^2\cdot^{\circ}\text{C}$ at one of its surfaces, while the other surface is kept at 70°C . What is the temperature of the surface that is exposed to cool air?

Answer: 44.9°C

3.3 Consider a furnace wall [$k=1\text{W/m}\cdot^{\circ}\text{C}$] with the inside surface at 1000°C and the outside surface at 400°C . If the heat flow through the wall should not exceed 2000W/m^2 . what is the minimum wall thickness ?

Answer: 30cm

3.4 Consider a plane wall 25cm thick. The inner surface is kept at 400°C , and the outer surface is exposed to an environment at 800°C with a heat transfer coefficient of $10\text{W/m}^2\cdot^{\circ}\text{C}$. If the temperature of the outer surface is 685°C , calculate the thermal conductivity of the wall. What might the material be?

- 3.5 A certain material 2.5cm thick, with a cross-sectional area of 0.1m^2 , has one side maintained at 35°C and the other at 95°C . The temperature at the center plane of the material is 62°C , and the heat flow through the material is 1kW. Obtain an expression for the thermal conductivity of the material as a function of temperature.
- 3.6 A composite wall is found of a 2.5cm copper plate, a 3.2mm layer of asbestos, and a 5cm layer of fiberglass. The wall is subjected to an overall temperature difference of 560°C . Calculate the heat flow per unit area through the composite structure.
- 3.7 An outside wall for a building consists of a 10cm layer of common brick and a 2.5cm layer of fiberglass [$k=0.05\text{W/m}\cdot^\circ\text{C}$]. Calculate the heat flow through the wall for a 45°C temperature differential.
- 3.8 A plane wall is constructed of a material having a thermal conductivity that varies as the square of the temperature according to the relation [$k=k_0(1+\beta T^2)$]. Derive an expression for the heat transfer in such a wall.

- 3.9 A certain building wall consists of 15cm concrete [$k=1.2\text{W/m}\cdot^\circ\text{C}$], 5cm of fiberglass insulation, and 3/8 in of gypsum [$k=0.06\text{ W/m}\cdot^\circ\text{C}$]. The inside and outside convection coefficients are 10 and $3.5\text{ W/m}^2\cdot^\circ\text{C}$, respectively. The outside air temperature is 5°C , and the inside temperature is 25°C . Calculate the over all heat transfer coefficient for the wall, the R value, and the heat loss per unit area.
- 3.10 Consider a 1.2m high and 2m wide double –pane window consisting of two 3mm thick of glass [$k=0.78\text{ W/m}\cdot^\circ\text{C}$] separated by a 12mm stagnant air space [$k=0.026\text{ W/m}\cdot^\circ\text{C}$]. Determine the steady rate of heat transfer through this double-pane window and the temperature of its inner surface for a day during which the room is maintained at 24°C while the temperature of the outdoors is 45°C . Take the convection heat transfer coefficients on the inner and outer surfaces of the window to be $h_1=10\text{ W/m}^2\cdot^\circ\text{C}$ and $h_2=25\text{ W/m}^2\cdot^\circ\text{C}$, and disregard any heat transfer by radiation.
- 3.13 A metal pipe with an outside diameter (OD) of 12cm is covered with an insulation material [$k=0.07\text{W/m}\cdot^\circ\text{C}$] of 2.5cm thick. If the outer pipe wall is at 100°C and the outer surface of the insulation is at 20°C , find the heat loss from the pipe per meter length.

Answer: 101W/m length

3.14 A metal pipe of 10cm OD is covered with a 2cm thick insulation [$k=0.07\text{W/m}\cdot^\circ\text{C}$]. The heat loss from the pipe is 100W per meter of length when the pipe surface is at 100°C . What is the temperature of the outer surface of the insulation? Answer: 23.5°C

3.15 A 5cm OD and 0.5cm thick copper pipe [$k=386\text{W/m}\cdot^\circ\text{C}$] has hot gas flowing inside at a temperature of 200°C with a heat transfer coefficient of $30\text{W/m}^2\cdot^\circ\text{C}$. The outer surface dissipates heat by convection into the ambient air at 20°C with a heat transfer coefficient of $15\text{W/m}^2\cdot^\circ\text{C}$. determine the heat loss from the pipe per meter length.

Answer: 261W/m length

3.16 A brass condenser tube [$k=115\text{W/m}\cdot^\circ\text{C}$] with an outside diameter of 2cm and a thickness of 0.2cm is used to condense steam on its outer surface at 50°C with a heat transfer coefficient of $2000\text{W/m}^2\cdot^\circ\text{C}$. Cooling water at 20°C with a heat transfer coefficient of $5000\text{W/m}^2\cdot^\circ\text{C}$ flows inside. (a) Determine the overall heat transfer coefficient based of the outer surface and the heat flow rate from the steam to the cooling water per meter of length of the tube. (b) What would be the heat transfer rate per meter of length of the tube if the outer and inner surfaces of the tube were at 50°C and 20°C , respectively? Compare this result with (a), and explain the reason for the difference between the two results.

3.17 A steel tube [$k=15\text{W/m}\cdot^\circ\text{C}$] with an outside diameter of 7.6cm and a thickness of 1.3cm is covered with an insulation material [$k=0.2\text{W/m}\cdot^\circ\text{C}$] 2cm thick. A hot gas at 330°C with a heat transfer coefficient of $400\text{W/m}^2\cdot^\circ\text{C}$, flows inside the tube. The outer surface of the insulation is exposed to cooler air at 30°C with a heat transfer coefficient of $60\text{W/m}^2\cdot^\circ\text{C}$. Calculate the heat loss from the tube to the air for a 10m length of the tube.
Answer: 7453W

3.18 Consider pipe of inside radius $r_1=2\text{cm}$, outside radius $r_2=4\text{cm}$, and thermal conductivity [$k_1=10\text{W/m}\cdot^\circ\text{C}$]. The inside surface is maintained at a uniform temperature $T_1=300^\circ\text{C}$, and the outside surface is to be insulated with an insulation material of thermal conductivity [$k_2=0.1\text{W/m}\cdot^\circ\text{C}$]. The outside surface of the insulation material is exposed to an environment at $T_{\infty 2}=20^\circ\text{C}$ with a heat transfer coefficient $h_{\infty 2}=10\text{W/m}^2\cdot^\circ\text{C}$. Develop an expression for determining the thickness L of the insulation material needed to reduce the heat loss by 30 percent of that of the uninsulated pipe exposed to the same environment condition.

Answer: 0.0062m

3.19 A steel tube [$k=15\text{W/m}\cdot^\circ\text{C}$] with an outside diameter of 7.6cm and a thickness of 1.3cm is covered with an insulation [$k=0.2\text{W/m}\cdot^\circ\text{C}$] 2cm thick. A hot gas with a heat transfer coefficient of $400\text{W/m}^2\cdot^\circ\text{C}$, flows inside the tube, and the outside surface of the insulation is exposed to cooler air with a heat transfer coefficient of $60\text{W/m}^2\cdot^\circ\text{C}$. Calculate the overall heat transfer coefficient U based on the outside surface area of the insulation.

3.20 A cylindrical steam pipe having an inside surface temperature of 250°C has an inside diameter of 8cm and a wall thickness of 5.5mm. It is covered with a 9cm layer of insulation having $k=0.5\text{W/m}\cdot^{\circ}\text{C}$, followed by a 4cm layer of insulation having $k=0.25\text{W/m}\cdot^{\circ}\text{C}$. The outside temperature of the insulation is 20°C . Calculate the heat lost per meter of length. Assume $k=47\text{W/m}\cdot^{\circ}\text{C}$ for the pipe.

3.21 Consider a hollow sphere with an inner radius of 5cm and outer radius of 6cm. The inner surface is kept at 100°C , and the outer surface at 50°C . Determine the heat loss from the sphere if it is made of pure copper [$k=387\text{W/m}\cdot^{\circ}\text{C}$], pure aluminum [$k=200\text{W/m}\cdot^{\circ}\text{C}$], and pure iron [$k=62\text{W/m}\cdot^{\circ}\text{C}$].

Answer: 72.95kW, 37.7kW, 11.69kW

3.22 A 6cm OD, 2cm thick copper hollow sphere [$k=386\text{W/m}\cdot^{\circ}\text{C}$] is uniformly heated at the inner surface at a rate of 150W/m^2 . The outside surface is cooled with air at 20°C with a heat transfer coefficient of $10\text{W/m}^2\cdot^{\circ}\text{C}$. Calculate the temperature of the outer surface.

Answer: 21.7°C

3.23 A spherical tank, 1m in diameter, is maintained at a temperature of 120°C and exposed to a convection environment with $h=25\text{W/m}^2\cdot^{\circ}\text{C}$ and $T_{\infty}=15^{\circ}\text{C}$, what thickness of urethane foam should be added to ensure temperature of the insulation does not exceed 40°C ? What percentage reduction in heat loss results from installing this insulation.

- 3.24 A hollow sphere is constructed of aluminum with an inner diameter of 4cm and an outer diameter of 8cm. The inside temperature is 100°C and the outer temperature is 50°C . Calculate the heat transfer.
- 3.25 Consider a hollow steel sphere [$k=15\text{W/m}\cdot^{\circ}\text{C}$] with an inside radius of 5cm and an outside radius of 10cm. The outside surface is to be insulated with a fiberglass insulation [$k=0.05\text{W/m}\cdot^{\circ}\text{C}$] to reduce the heat flow rate through the sphere wall by 50 percent. Determine the thickness of the fiberglass.
Answer: 0.05cm
- 3.26 A steel tube [$k=15\text{W/m}\cdot^{\circ}\text{C}$] with an outside diameter of 7.6cm and a thickness of 1.3cm is covered with an insulation [$k=0.2\text{W/m}\cdot^{\circ}\text{C}$] 2cm thick. A hot gas with a heat transfer coefficient of $400\text{W/m}^2\cdot^{\circ}\text{C}$ flows inside the tube, and the outer surface of the insulation is exposed to cooler air with a heat transfer coefficient of $60\text{W/m}^2\cdot^{\circ}\text{C}$. Calculate the overall heat transfer coefficient U based on the outside surface area of the insulation.
- 3.27 A 2mm diameter and 10m long electric wire is tightly wrapped with a 1mm thick plastic cover whose thermal conductivity is $k=0.15\text{W/m}\cdot^{\circ}\text{C}$. Electrical measurements indicate that a current of 10A passes through the wire and there is a voltage drop of 8V along the wire. If the insulated wire is exposed to a medium at $T_{\infty}=30^{\circ}\text{C}$ with a heat transfer coefficient of $h=18\text{W/m}^2\cdot^{\circ}\text{C}$, determine the temperature at the interface of the wire and the plastic cover in steady operation. Also determine if doubling the thickness of the plastic cover will increase or decrease this interface temperature.

3.28 A 5mm diameter spherical ball at 50°C is covered by a 1mm thick plastic insulation [$k=0.13\text{W/m}\cdot^{\circ}\text{C}$]. The ball is exposed to a medium at 15°C , with a combined convection and radiation heat transfer coefficient of $20\text{W/m}^2\cdot^{\circ}\text{C}$. Determine if the plastic insulation on the ball will help or hurt heat transfer from the ball.

3.29 A 1.0mm diameter wire is maintained at a temperature of 400°C and exposed to a convection environment at 40°C . with $h=20\text{W/m}^2\cdot^{\circ}\text{C}$. Calculate the thermal conductivity which will just cause an insulation thickness of 0.2mm to reduce a "critical radius". How much of this insulation must be added to reduce the heat transfer by 75% from that which would be experienced by the bare wire?

3.30 Consider a 5-m-high, 8-m-long, and 0.22-m-thick wall whose representative cross section is as given in the figure. The thermal conductivities of various materials used, in $\text{W/m}\cdot^{\circ}\text{C}$, are $k_A = k_F = 2$, $k_B = 8$, $k_C = 20$, $k_D = 15$, and $k_E = 35$. The left and right surfaces of the wall are maintained at uniform temperatures of 300°C and 100°C , respectively. Assuming heat transfer through the wall to be one-dimensional, determine (a) the rate of heat transfer through the wall; (b) the temperature at the point where the sections B , D , and E meet; and (c) the temperature drop across the section F . Disregard any contact resistances at the interfaces.

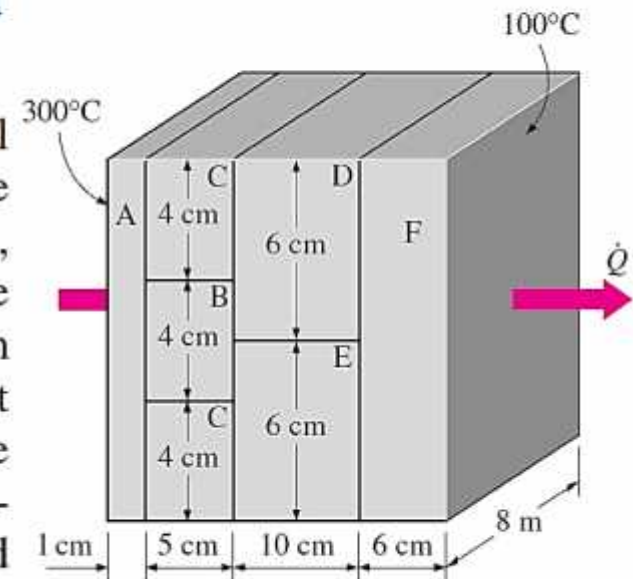

3.31 A 5-m-wide, 4-m-high, and 40-m-long kiln used to cure concrete pipes is made of 20-cm-thick concrete walls and ceiling ($k = 0.9 \text{ W/m} \cdot ^\circ\text{C}$). The kiln is maintained at 40°C by injecting hot steam into it. The two ends of the kiln, $4 \text{ m} \times 5 \text{ m}$ in size, are made of a 3-mm-thick sheet metal covered with 2-cm-thick Styrofoam ($k = 0.033 \text{ W/m} \cdot ^\circ\text{C}$). The convection heat transfer coefficients on the inner and the outer surfaces of the kiln are $3000 \text{ W/m}^2 \cdot ^\circ\text{C}$ and $25 \text{ W/m}^2 \cdot ^\circ\text{C}$, respectively. Disregarding any heat loss through the floor, determine the rate of heat loss from the kiln when the ambient air is at -4°C .

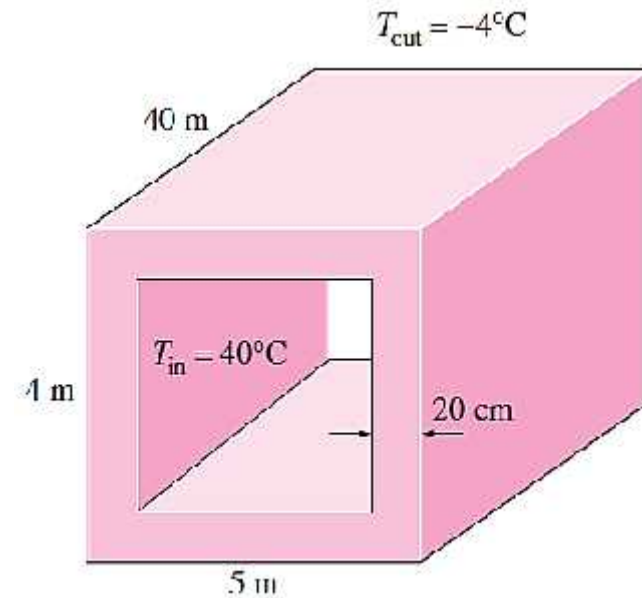

3.32 Consider a 1.2-m-high and 2-m-wide double-pane window consisting of two 3-mm-thick layers of glass ($k = 0.78 \text{ W/m} \cdot ^\circ\text{C}$) separated by a 12-mm-wide stagnant air space ($k = 0.026 \text{ W/m} \cdot ^\circ\text{C}$). Determine the steady rate of heat transfer through this double-pane window and the temperature of its inner surface for a day during which the room is maintained at 24°C while the temperature of the outdoors is -5°C . Take the convection heat transfer coefficients on the inner and outer

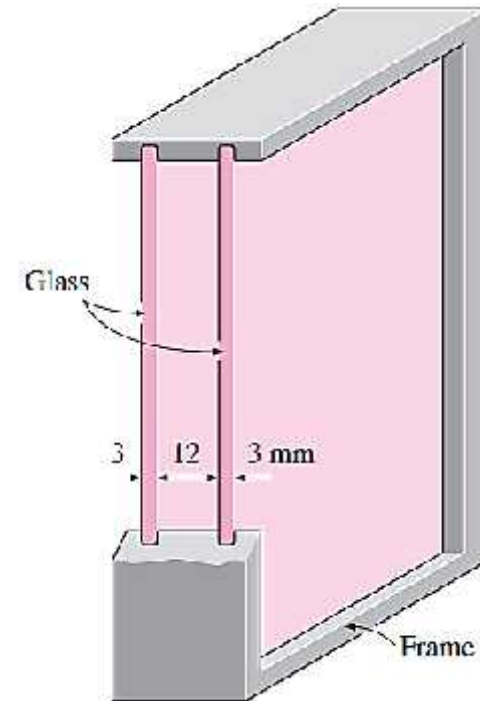

3-6 HEAT TRANSFER FROM FINNED SURFACES

The rate of heat transfer from a surface at a temperature T_s to the surrounding medium at T_∞ is given by Newton's law of cooling as

$$\dot{Q}_{\text{conv}} = hA_s(T_s - T_\infty)$$

where A_s is the heat transfer surface area and h is the convection heat transfer coefficient. When the temperatures T_s and T_∞ are fixed by design considerations, as is often the case, there are *two ways* to increase the rate of heat transfer: to increase the *convection heat transfer coefficient* h or to increase the *surface area* A_s . Increasing h may require the installation of a pump or fan, or replacing the existing one with a larger one, but this approach may or may not be practical. Besides, it may not be adequate. The alternative is to increase the surface area by attaching to the surface *extended surfaces* called *fins* made of highly conductive materials such as aluminum. Finned surfaces are manufactured by extruding, welding, or wrapping a thin metal sheet on a surface. Fins enhance heat transfer from a surface by exposing a larger surface area to convection and radiation.

Finned surfaces are commonly used in practice to enhance heat transfer, and they often increase the rate of heat transfer from a surface severalfold. The car radiator shown in Fig. 3-33 is an example of a finned surface. The closely packed thin metal sheets attached to the hot water tubes increase the surface area for convection and thus the rate of convection heat transfer from the tubes to the air many times. There are a variety of innovative fin designs available in the market, and they seem to be limited only by imagination (Fig. 3-34).

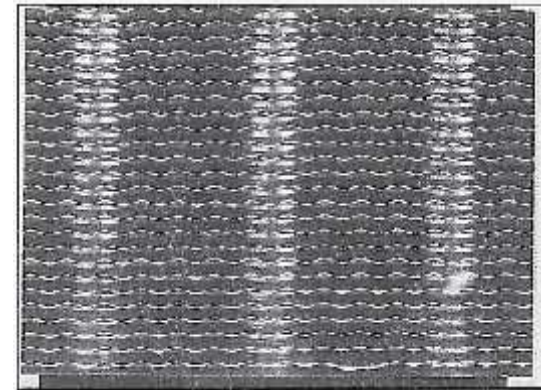

FIGURE 3-33

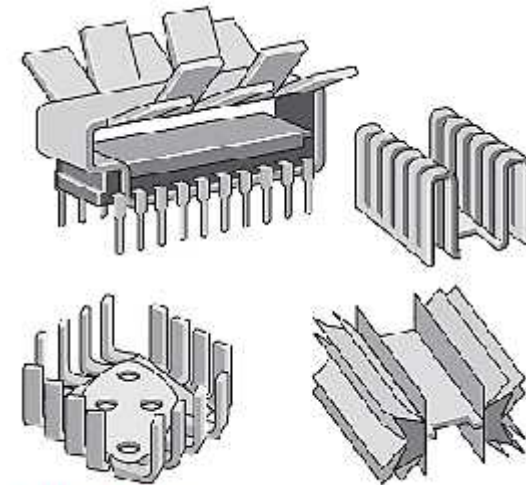

FIGURE 3-34

Fin Equation

Consider a volume element of a fin at location x having a length of Δx , cross-sectional area of A_c , and a perimeter of p , as shown in Fig. 3–35. Under steady conditions, the energy balance on this volume element can be expressed as

$$\left(\begin{array}{l} \text{Rate of heat} \\ \text{conduction into} \\ \text{the element at } x \end{array} \right) = \left(\begin{array}{l} \text{Rate of heat} \\ \text{conduction from the} \\ \text{element at } x + \Delta x \end{array} \right) + \left(\begin{array}{l} \text{Rate of heat} \\ \text{convection from} \\ \text{the element} \end{array} \right)$$

$$\dot{Q}_{\text{cond}, x} = \dot{Q}_{\text{cond}, x + \Delta x} + \dot{Q}_{\text{conv}}$$

where

$$\dot{Q}_{\text{conv}} = h(p \Delta x)(T - T_\infty)$$

Substituting and dividing by Δx , we obtain

$$\frac{\dot{Q}_{\text{cond}, x + \Delta x} - \dot{Q}_{\text{cond}, x}}{\Delta x} + hp(T - T_\infty) = 0$$

Taking the limit as $\Delta x \rightarrow 0$ gives

$$\frac{d\dot{Q}_{\text{cond}}}{dx} + hp(T - T_\infty) = 0 \quad \mathbf{a}$$

From Fourier's law of heat conduction we have

$$\dot{Q}_{\text{cond}} = -kA_c \frac{dT}{dx}$$

where A_c is the cross-sectional area of the fin at location x .

Substitution of this relation into Eq. a gives the differential equation governing heat transfer in fins,

$$\frac{d}{dx} \left(kA_c \frac{dT}{dx} \right) - hp(T - T_\infty) = 0 \quad \mathbf{b}$$

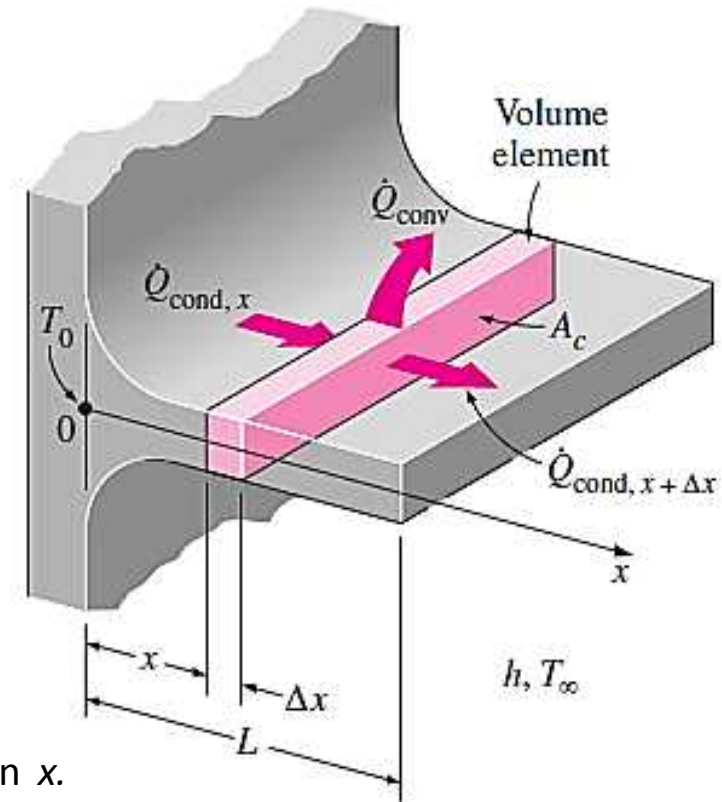

FIGURE 3–35

Volume element of a fin at location x having a length of Δx , cross-sectional area of A_c , and perimeter of p .

In general, the cross-sectional area A_c and the perimeter p of a fin vary with x , which makes this differential equation difficult to solve. In the special case of *constant cross section* and *constant thermal conductivity*, the differential equation b reduces to

$$\frac{d^2\theta}{dx^2} - a^2\theta = 0 \quad \text{c}$$

where

$$a^2 = \frac{hp}{kA_c}$$

and $\theta = T - T_\infty$ is the *temperature excess*. At the fin base we have $\theta_b = T_b - T_\infty$.

Therefore, the general solution of the differential equation Eq. c is

$$\theta(x) = C_1e^{ax} + C_2e^{-ax} \quad \text{d}$$

where C_1 and C_2 are arbitrary constants whose values are to be determined from the boundary conditions at the base and at the tip of the fin. Note that we need only two conditions to determine C_1 and C_2 uniquely.

At the fin tip we have several possibilities, including specified temperature, negligible heat loss (idealized as an insulated tip), convection, and combined convection and radiation (Fig. 3–36). Next, we consider each case separately.

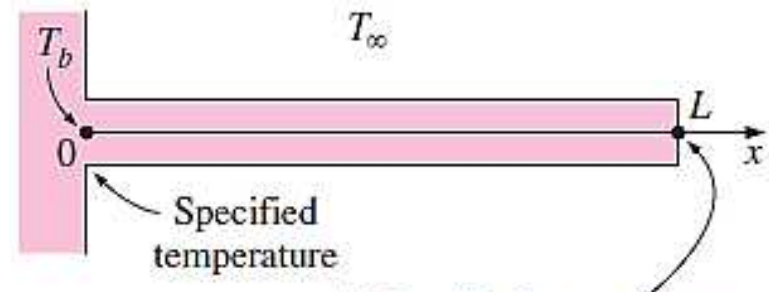

- (a) Specified temperature
- (b) Negligible heat loss
- (c) Convection
- (d) Convection and radiation

FIGURE 3–36

1 Infinitely Long Fin ($T_{\text{fin tip}} = T_{\infty}$)

For long fin of uniform cross section ($A_c = \text{constant}$) the temperature at the fin tip will approach the environment temperature T_{∞} and θ will approach zero. That is

Boundary condition at fin tip $\theta(L) = T(L) - T_{\infty} = 0$ as $L \rightarrow \infty$

By substituting these two boundary conditions in equation (d) we get

B.C.1 $\theta_o = C_1 + C_2$ B.C.2 $0 = C_1 e^{-\infty} + C_2 e^{\infty}$

From second boundary equation, we note that $e^{-\infty} \rightarrow 0$ so $C_1 \neq 0$ then $C_2 = 0$.

Then from B.C.1 equation we get that $C_1 = \theta_o$

The final equation of temperature distribution through a long fin is

Very long fin:
$$\frac{T(x) - T_{\infty}}{T_b - T_{\infty}} = e^{-ax} = e^{-x\sqrt{hp/kA_c}}$$

The steady rate of heat transfer from the entire fin can be determined from Fourier's law of heat conduction

$$\begin{aligned} \dot{Q}_{\text{long fin}} &= -kA_c \left. \frac{dT}{dx} \right|_{x=0} = -kA_c \left. \frac{d\theta}{dx} \right|_{x=0} = -kA_c \theta_o \left. \frac{d\left(e^{-x\sqrt{hp/kc}}\right)}{dx} \right|_{x=0} \\ &= -kA_c \theta_o \left(-\sqrt{hp/kA_c} \right) e^{-x\sqrt{hp/kA_c}} \Big|_{x=0} \end{aligned}$$

Then
$$\dot{Q}_{\text{long fin}} = \sqrt{hpkA_c} \theta_o = \sqrt{hkpA_c} (T_o - T_{\infty})$$

where p is the perimeter, A_c is the cross-sectional area of the fin, and x is the distance from the fin base

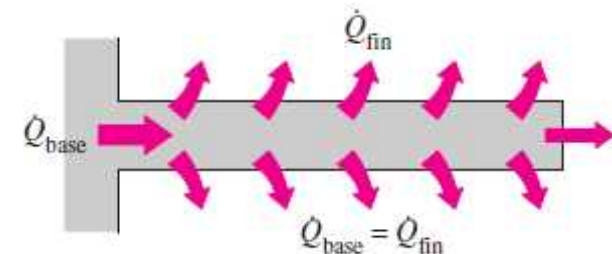
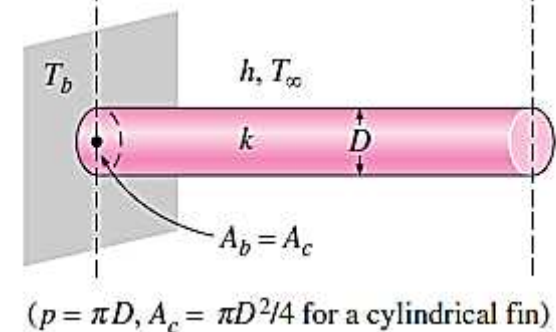
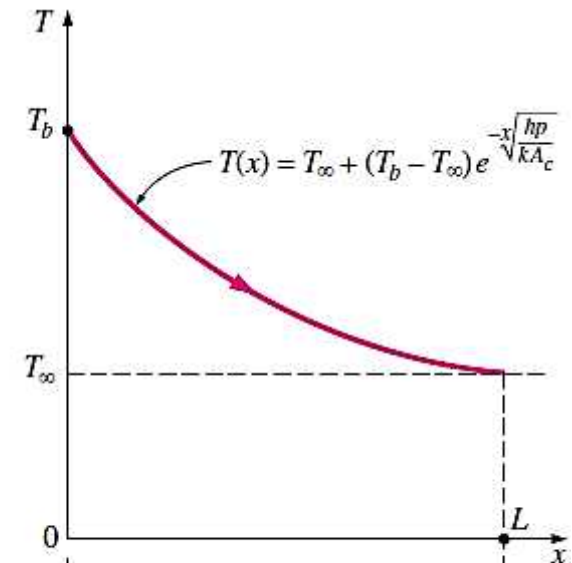

The rate of heat transfer from the fin could also be determined by considering heat transfer from a differential volume element of the fin and integrating it over the entire surface of the fin. That is

$$\begin{aligned}\dot{Q}_{\text{long fin}} &= \int_0^{\infty} h[T(x) - T_{\infty}]P dx = \int_0^{\infty} hp\theta(x) dx = \int_0^{\infty} hp\theta_0 e^{-x\sqrt{hp/kA_c}} dx \\ &= \frac{hp\theta_0}{-\sqrt{hp/kA_c}} (e^{-\infty} - e^0) = \sqrt{hkpA_c}\theta_0 = \sqrt{hkpA_c}(T_b - T_{\infty})\end{aligned}$$

2 Negligible Heat Loss from the Fin Tip (Insulated fin tip, $\dot{Q}_{\text{fin tip}} = 0$)

Fins are not likely to be so long that their temperature approaches the surrounding temperature at the tip. A more realistic situation is for heat transfer from the fin tip to be negligible since the heat transfer from the fin is proportional to its surface area, and the surface area of the fin tip is usually a negligible fraction of the total fin area. Then the fin tip can be assumed to be insulated, and the condition at the fin tip can be expressed as

$$\text{Boundary condition at fin tip:} \quad \left. \frac{d\theta}{dx} \right|_{x=L} = 0$$

$$\text{Boundary condition at fin base:} \quad \theta(0) = \theta_b = T_b - T_{\infty}$$

The application of these two conditions on the general solution (Eq. d) yields, after some manipulations, this relation for the temperature distribution

$$\text{Adiabatic fin tip:} \quad \frac{T(x) - T_{\infty}}{T_b - T_{\infty}} = \frac{\cosh a(L - x)}{\cosh aL}$$

The rate of heat transfer from the fin can be determined again from Fourier's law of heat conduction:

$$\begin{aligned}\text{Adiabatic fin tip:} \quad \dot{Q}_{\text{insulated tip}} &= -kA_c \left. \frac{dT}{dx} \right|_{x=0} \\ &= \sqrt{hpkA_c}(T_b - T_{\infty}) \tanh aL\end{aligned}$$

3 Convection (or Combined Convection and Radiation) from Fin Tip

The fin tips, are exposed to the surroundings, and thus the proper boundary condition for the fin tip is convection that also includes the effects of radiation. The fin equation can still be solved in this case using the convection at the fin tip as the second boundary condition. This condition for the fin tip is

$$\text{At } x=L \quad -kA_c \left. \frac{dT}{dx} \right|_{x=L} = hA_c (T_L - T_\infty) \quad \text{or} \quad \left. \frac{d\theta}{dx} \right|_{x=L} = -\frac{h}{k} \theta_L$$

Boundary condition at fin base: $\theta(0) = \theta_b = T_b - T_\infty$

The application of these two conditions on the general solution (Eq. d) yields, after some manipulations, this relation for the temperature distribution

$$\frac{\theta(x)}{\theta_o} = \frac{T - T_\infty}{T_o - T_\infty} = \frac{\cosh[m(L-x)] + \frac{h}{km} \sinh[m(L-x)]}{\cosh(mL) + \frac{h}{km} \sinh(mL)}$$

the heat transfer from this fin can be expressed in the same way as it is done for the previous two type and it will be as

$$\dot{Q} = \sqrt{hkpA_c} (T_o - T_\infty) \frac{\sinh(mL) + \frac{h}{km} \cosh(mL)}{\cosh(mL) + \frac{h}{km} \sinh(mL)}$$

Fin Efficiency

Consider the surface of a *plane wall* at temperature T_b exposed to a medium at temperature T_∞ . Heat is lost from the surface to the surrounding medium by convection with a heat transfer coefficient of h . Disregarding radiation or accounting for its contribution in the convection coefficient h , heat transfer from a surface area A_s is expressed as $\dot{Q} = hA_s(T_b - T_\infty)$.

Now let us consider a fin of constant cross-sectional area $A_c = A_b$ and length L that is attached to the surface with a perfect contact (Fig. 3–40). This time heat will flow from the surface to the fin *by conduction* and from the fin to the surrounding medium *by convection* with the same heat transfer coefficient h . The temperature of the fin will be T_b at the fin base and gradually decrease toward the fin tip. Convection from the fin surface causes the temperature at any cross section to drop somewhat from the midsection toward the outer surfaces. However, the cross-sectional area of the fins is usually very small, and thus the temperature at any cross section can be considered to be uniform. Also, the fin tip can be assumed for convenience and simplicity to be insulated by using the corrected length for the fin instead of the actual length.

In the limiting case of *zero thermal resistance* or *infinite thermal conductivity* ($k \rightarrow \infty$), the temperature of the fin will be uniform at the base value of T_b . The heat transfer from the fin will be *maximum* in this case and can be expressed as

$$\dot{Q}_{\text{fin, max}} = hA_{\text{fin}}(T_b - T_\infty)$$

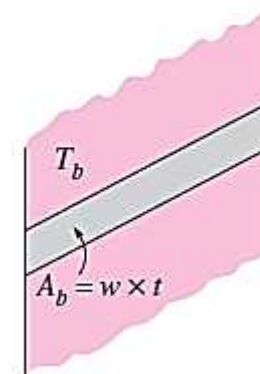

(a) Surface without fins

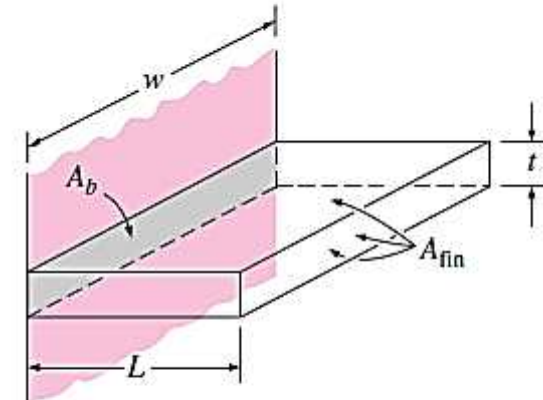

(b) Surface with a fin

$$\begin{aligned} A_{\text{fin}} &= 2 \times w \times L + w \times t \\ &\cong 2 \times w \times L \end{aligned}$$

FIGURE 3–40

In reality, however, the temperature of the fin will drop along the fin, and thus the heat transfer from the fin will be less because of the decreasing temperature difference $T(x) - T_\infty$ toward the fin tip, as shown in Fig. 3-41. To account for the effect of this decrease in temperature on heat transfer, we define a **fin efficiency** as

$$\eta_{\text{fin}} = \frac{\dot{Q}_{\text{fin}}}{\dot{Q}_{\text{fin, max}}} = \frac{\text{Actual heat transfer rate from the fin}}{\text{Ideal heat transfer rate from the fin if the entire fin were at base temperature}} \quad \text{or}$$

$$\dot{Q}_{\text{fin}} = \eta_{\text{fin}} \dot{Q}_{\text{fin, max}} = \eta_{\text{fin}} h A_{\text{fin}} (T_b - T_\infty)$$

where A_{fin} is the total surface area of the fin. This relation enables us to determine the heat transfer from a fin when its efficiency is known. For the cases of constant cross section of *very long fins* and *fins with insulated tips*, the fin efficiency can be expressed as

$$\eta_{\text{long fin}} = \frac{\dot{Q}_{\text{fin}}}{\dot{Q}_{\text{fin, max}}} = \frac{\sqrt{hp k A_c} (T_b - T_\infty)}{h A_{\text{fin}} (T_b - T_\infty)} = \frac{1}{L} \sqrt{\frac{k A_c}{hp}} = \frac{1}{aL} \quad \text{and}$$

$$\eta_{\text{insulated tip}} = \frac{\dot{Q}_{\text{fin}}}{\dot{Q}_{\text{fin, max}}} = \frac{\sqrt{hp k A_c} (T_b - T_\infty) \tanh aL}{h A_{\text{fin}} (T_b - T_\infty)} = \frac{\tanh aL}{aL}$$

since $A_{\text{fin}} = pL$ for fins with constant cross section.

Fin efficiency relations are developed for fins of various profiles and are plotted in Fig. 3-42 for fins on a *plain surface* and in Fig. 3-43 for *circular fins* of constant thickness. The fin surface area associated with each profile is also given on each figure. For most fins of constant thickness encountered in practice, the fin thickness t is too small relative to the fin length L , and thus the fin tip area is negligible.

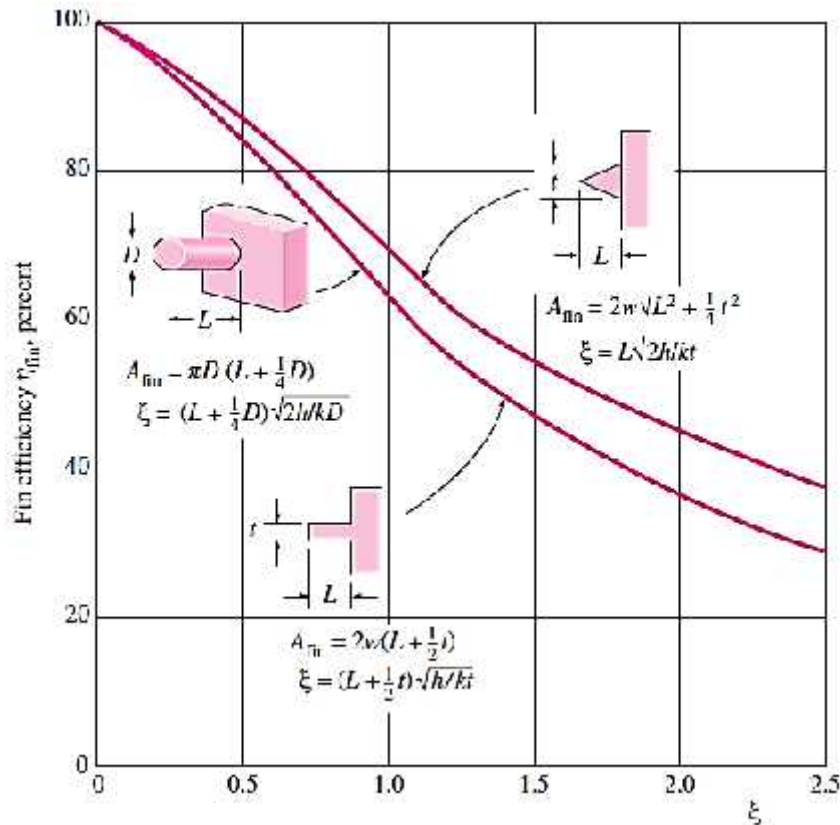

FIGURE 3-42
Efficiency of circular, rectangular, and triangular fins on a plain surface of width w

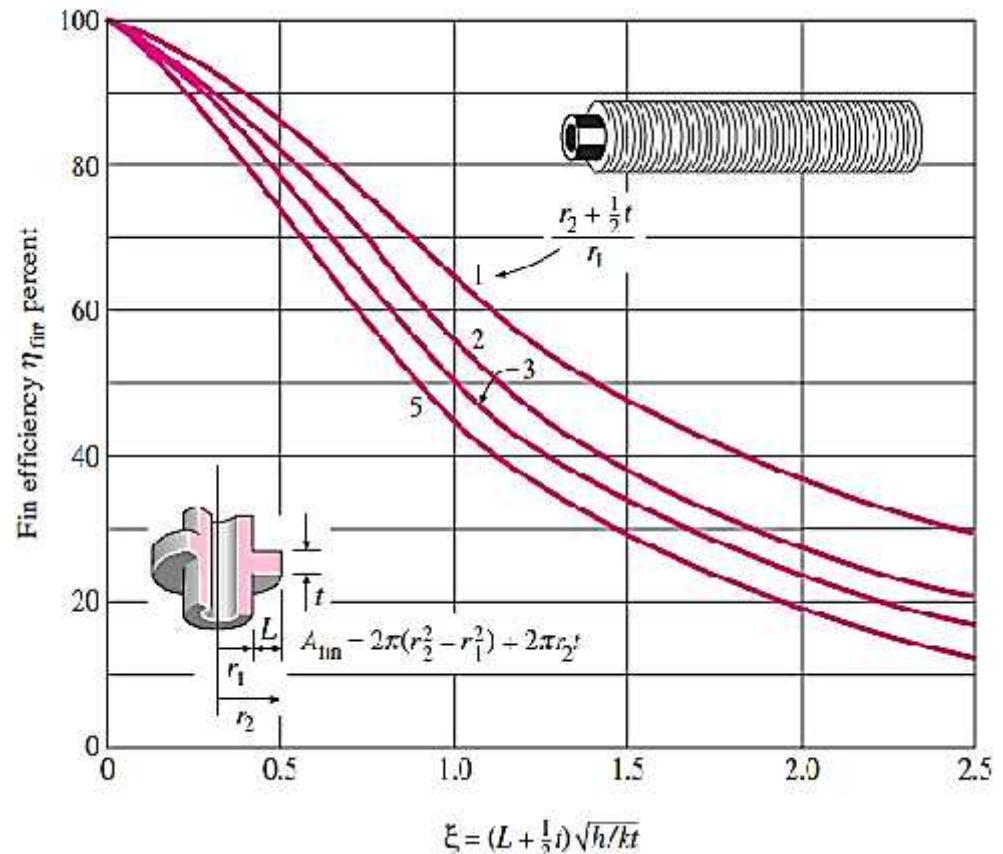

FIGURE 3-43
Efficiency of circular fins of length L and constant thickness t

Fin Effectiveness

Fins are used to *enhance* heat transfer, and the use of fins on a surface cannot be recommended unless the enhancement in heat transfer justifies the added cost and complexity associated with the fins. In fact, there is no assurance that adding fins on a surface will *enhance* heat transfer. The performance of the fins is judged on the basis of the enhancement in heat transfer relative to the no-fin case. The performance of fins expressed in terms of the *fin effectiveness* ϵ_{fin} is defined as (Fig. 3–44)

$$\epsilon_{\text{fin}} = \frac{\dot{Q}_{\text{fin}}}{\dot{Q}_{\text{no fin}}} = \frac{\dot{Q}_{\text{fin}}}{hA_b(T_b - T_\infty)} = \frac{\text{Heat transfer rate from the fin of base area } A_b}{\text{Heat transfer rate from the surface of area } A_b}$$

Note that both the fin efficiency and fin effectiveness are related to the performance of the fin, but they are different quantities. However, they are related to each other by

$$\epsilon_{\text{fin}} = \frac{\dot{Q}_{\text{fin}}}{\dot{Q}_{\text{no fin}}} = \frac{\dot{Q}_{\text{fin}}}{hA_b(T_b - T_\infty)} = \frac{\eta_{\text{fin}} hA_{\text{fin}}(T_b - T_\infty)}{hA_b(T_b - T_\infty)} = \frac{A_{\text{fin}}}{A_b} \eta_{\text{fin}}$$

Therefore, the fin effectiveness can be determined easily when the fin efficiency is known, or vice versa.

The effectiveness of such a long fin is determined to be

$$\epsilon_{\text{long fin}} = \frac{\dot{Q}_{\text{fin}}}{\dot{Q}_{\text{no fin}}} = \frac{\sqrt{hp k A_c} (T_b - T_\infty)}{hA_b (T_b - T_\infty)} = \sqrt{\frac{kp}{hA_c}}$$

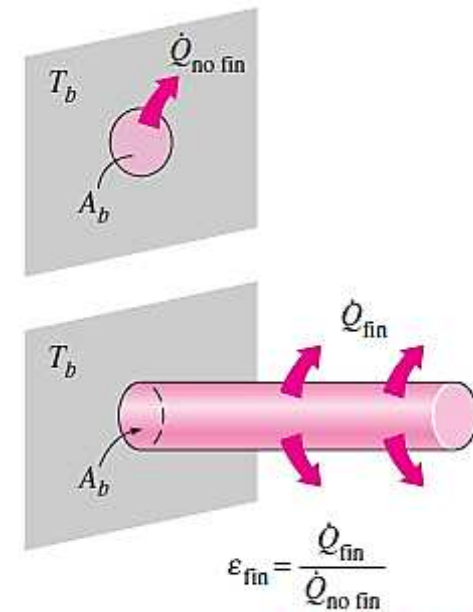

FIGURE 3–44

Example 3.7

Copper-plate fins of rectangular cross section having a thickness $t=1\text{mm}$, height $L=10\text{mm}$, and thermal conductivity $k=380\text{W/m}\cdot^\circ\text{C}$ are attached to a plane wall maintained at a temperature $T_0=230^\circ\text{C}$. The fins dissipate heat by convection into ambient at $T_\infty=30^\circ\text{C}$ with a heat transfer coefficient $h=40\text{W/m}^2\cdot^\circ\text{C}$. Assuming negligible heat loss from the fin tip determine the fin efficiency

Solution

to determine the fin efficiency, we first calculate the parameter mL as follows

$$\frac{P}{A} = \frac{2(b+t)}{bt} = \frac{2}{t}$$

$$m = \sqrt{\frac{Ph}{kA}} = \sqrt{\frac{2h}{kt}} = \sqrt{\frac{2(40\text{W/m}^2\cdot^\circ\text{C})}{(380\text{W/m}\cdot^\circ\text{C})(10^{-3}\text{m})}} = 14.51\text{m}^{-1}$$

$$mL = (14.51\text{m}^{-1})(0.01\text{m}) = .1451$$

$$\eta_{fin} = \frac{\tanh mL}{mL} = \frac{\tanh(0.1451)}{0.1451} = 0.993 = 99.3\%$$

Example 3.8

A steel rod of diameter $D=2\text{cm}$, length $L=10\text{cm}$, and thermal conductivity $k=50\text{W/m}\cdot^\circ\text{C}$. is exposed to ambient air at $T_\infty = 20^\circ\text{C}$ with a heat transfer coefficient $h=30\text{W/m}^2\cdot^\circ\text{C}$. If one end of the rod is maintained at a temperature of 70°C . calculate the heat loss from the rod.

Solution

we can assume the rod to be a fin of the second type because it has a finite length. At the beginning we can calculate mL

$$\frac{p}{A} = \frac{\pi D}{\frac{\pi}{4} D^2} = \frac{4}{D}$$

$$m = \sqrt{\frac{ph}{kA}} = \sqrt{\frac{4h}{kD}} = \sqrt{\frac{4(30\text{W/m}\cdot^\circ\text{C})}{(50\text{W/m}^2\cdot^\circ\text{C})(0.02\text{m})}} = 10.95\text{m}^{-1}$$

$$mL = (10.95\text{m}^{-1})(0.1\text{m}) = 1.095$$

$$\dot{Q} = \theta_o \sqrt{phkA} \tanh mL$$

$$\dot{Q} = (T_o - T_\infty) \sqrt{(\pi D) hk (\pi D / 4)} \tanh mL$$

$$\dot{Q} = (70^\circ\text{C} - 20^\circ\text{C}) \sqrt{(\pi \times 0.02\text{m}) (30\text{W/m}^2\cdot^\circ\text{C}) (50\text{W/m}\cdot^\circ\text{C}) (\pi \times (0.02\text{m})^2 / 4)} \tanh(1.095)$$

$$\dot{Q} = 6.87\text{W}$$

now to find the temperature at the other end where $x=L$

$$\frac{\theta}{\theta_o} = \frac{T(x) - T_\infty}{T_o - T_\infty} = \frac{\cosh[m(L-x)]}{\cosh(mL)} \Rightarrow \frac{T(L) - 20}{70 - 20} = \frac{\cosh[m(L-L)]}{\cosh(1.095)} = .6017 \Rightarrow T(L) = 50.087^\circ\text{C}$$

EXAMPLE 3–9 Effect of Fins on Heat Transfer from Steam Pipes

Steam in a heating system flows through tubes whose outer diameter is $D_1 = 3$ cm and whose walls are maintained at a temperature of 120°C . Circular aluminum fins ($k = 180$ W/m \cdot $^\circ\text{C}$) of outer diameter $D_2 = 6$ cm and constant thickness $t = 2$ mm are attached to the tube, as shown in Fig. 3–48. The space between the fins is 3 mm, and thus there are 200 fins per meter length of the tube. Heat is transferred to the surrounding air at $T_\infty = 25^\circ\text{C}$, with a combined heat transfer coefficient of $h = 60$ W/m 2 \cdot $^\circ\text{C}$. Determine the increase in heat transfer from the tube per meter of its length as a result of adding fins.

SOLUTION

Analysis In the case of no fins, heat transfer from the tube per meter of its length is determined from Newton's law of cooling to be

$$A_{\text{no fin}} = \pi D_1 L = \pi(0.03 \text{ m})(1 \text{ m}) = 0.0942 \text{ m}^2$$

$$\dot{Q}_{\text{no fin}} = hA_{\text{no fin}}(T_b - T_\infty)$$

$$= (60 \text{ W/m}^2 \cdot ^\circ\text{C})(0.0942 \text{ m}^2)(120 - 25)^\circ\text{C}$$

$$= 537 \text{ W}$$

The efficiency of the circular fins attached to a circular tube is plotted in Fig. 3–43. Noting that $L = \frac{1}{2}(D_2 - D_1) = \frac{1}{2}(0.06 - 0.03) = 0.015$ m in this case, we have

$$\frac{r_2 + \frac{1}{2}t}{r_1} = \frac{(0.03 + \frac{1}{2} \times 0.002) \text{ m}}{0.015 \text{ m}} = 2.07$$

$$(L + \frac{1}{2}t) \sqrt{\frac{h}{kt}} = (0.015 + \frac{1}{2} \times 0.002) \text{ m} \times \sqrt{\frac{60 \text{ W/m}^2 \cdot ^\circ\text{C}}{(180 \text{ W/m} \cdot ^\circ\text{C})(0.002 \text{ m})}} = 0.207$$

$$\left. \begin{array}{l} \frac{r_2 + \frac{1}{2}t}{r_1} = 2.07 \\ (L + \frac{1}{2}t) \sqrt{\frac{h}{kt}} = 0.207 \end{array} \right\} \eta_{\text{fin}} = 0.95$$

$$A_{\text{fin}} = 2\pi(r_2^2 - r_1^2) + 2\pi r_2 t$$

$$= 2\pi[(0.03 \text{ m})^2 - (0.015 \text{ m})^2] + 2\pi(0.03 \text{ m})(0.002 \text{ m})$$

$$= 0.00462 \text{ m}^2$$

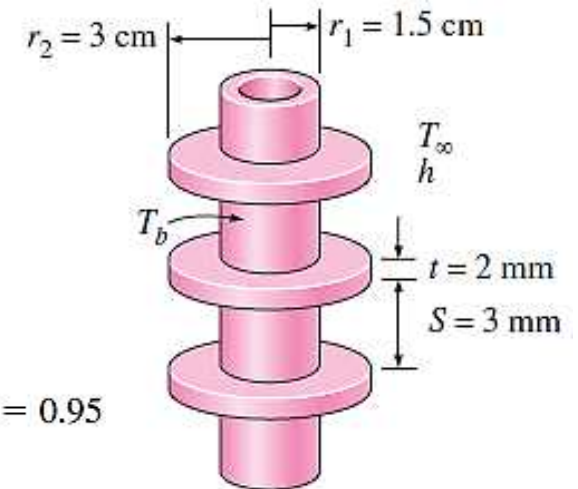
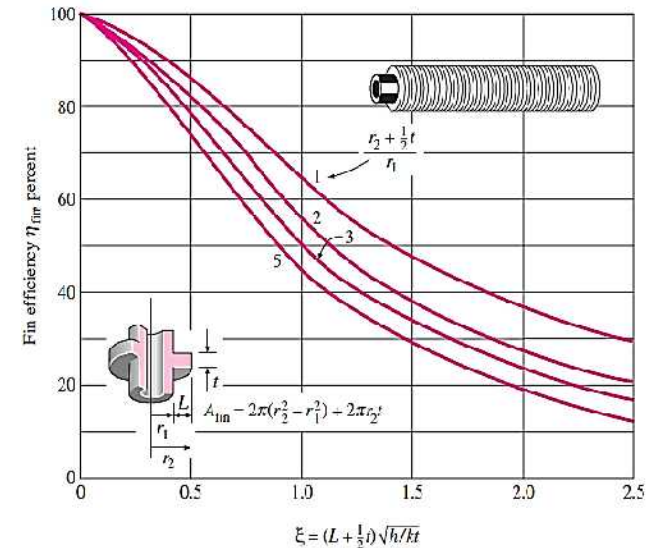

$$\begin{aligned}\dot{Q}_{\text{fin}} &= \eta_{\text{fin}} \dot{Q}_{\text{fin, max}} = \eta_{\text{fin}} h A_{\text{fin}} (T_b - T_\infty) \\ &= 0.95 (60 \text{ W/m}^2 \cdot ^\circ\text{C}) (0.00462 \text{ m}^2) (120 - 25) ^\circ\text{C} \\ &= 25.0 \text{ W}\end{aligned}$$

Heat transfer from the unfinned portion of the tube is

$$\begin{aligned}A_{\text{unfin}} &= \pi D_1 S = \pi (0.03 \text{ m}) (0.003 \text{ m}) = 0.000283 \text{ m}^2 \\ \dot{Q}_{\text{unfin}} &= h A_{\text{unfin}} (T_b - T_\infty) \\ &= (60 \text{ W/m}^2 \cdot ^\circ\text{C}) (0.000283 \text{ m}^2) (120 - 25) ^\circ\text{C} \\ &= 1.60 \text{ W}\end{aligned}$$

Noting that there are 200 fins and thus 200 interfin spacings per meter length of the tube, the total heat transfer from the finned tube becomes

$$\dot{Q}_{\text{total, fin}} = n(\dot{Q}_{\text{fin}} + \dot{Q}_{\text{unfin}}) = 200(25.0 + 1.6) \text{ W} = 5320 \text{ W}$$

Therefore, the increase in heat transfer from the tube per meter of its length as a result of the addition of fins is

$$\dot{Q}_{\text{increase}} = \dot{Q}_{\text{total, fin}} - \dot{Q}_{\text{no fin}} = 5320 - 537 = \mathbf{4783 \text{ W}} \quad (\text{per m tube length})$$

Discussion The overall effectiveness of the finned tube is

$$\varepsilon_{\text{fin, overall}} = \frac{\dot{Q}_{\text{total, fin}}}{\dot{Q}_{\text{total, no fin}}} = \frac{5320 \text{ W}}{537 \text{ W}} = 9.9$$

That is, the rate of heat transfer from the steam tube increases by a factor of almost 10 as a result of adding fins. This explains the widespread use of finned surfaces.

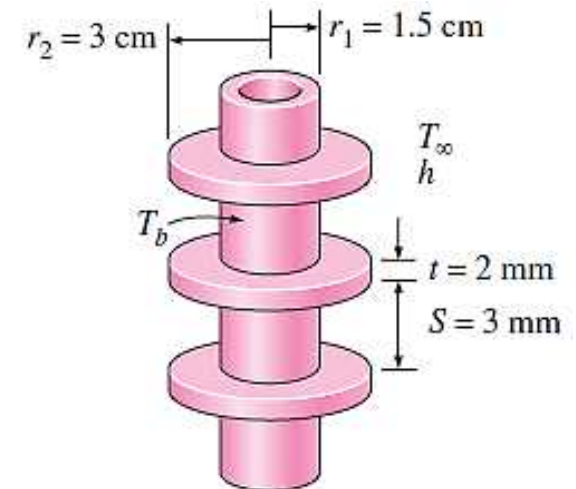

Problems Group B

Aluminum fins of rectangular profile are attached on a plane wall. The fins have thickness $t=1\text{mm}$, length $L=10\text{mm}$, and thermal conductivity $k=200\text{W/m}\cdot^\circ\text{C}$. The wall is maintained at a temperature $T_b=200^\circ\text{C}$, and the fins dissipate heat by convection into the ambient air at $T_\infty=40^\circ\text{C}$ with a heat transfer coefficient $h_c=50\text{W/m}^2\cdot^\circ\text{C}$. Determine the fin efficiency.
Answer: 0.98

Circular aluminum fins of constant rectangular profile are attached to a tube of outside diameter $D=5\text{cm}$. The fins have thickness $t=2\text{mm}$, height $L=15\text{mm}$, and thermal conductivity $k=200\text{W/m}\cdot^\circ\text{C}$. The tube surface is maintained at a uniform temperature $T_b=200^\circ\text{C}$, and the fins dissipate heat by convection into the ambient air at $T_\infty=30^\circ\text{C}$ with a heat transfer coefficient $h_c=50\text{W/m}^2\cdot^\circ\text{C}$. Determine the fin efficiency.

Answer: 0.96

An iron rod of length $L=30\text{cm}$, diameter $D=1\text{cm}$, and thermal conductivity $k=65\text{W/m}\cdot^\circ\text{C}$ is attached horizontally to a large tank at temperature $T_b=200^\circ\text{C}$. The rod is dissipating heat by convection into ambient air at $T_\infty=20^\circ\text{C}$ with a heat transfer coefficient $h_c=15\text{W/m}^2\cdot^\circ\text{C}$. What is the temperature of the rod at distances of 10 and 20cm from the tank surface?
Answer: 90.1°C , 50°C

An aluminum fin of rectangular profile has a thickness $t=2\text{mm}$, length $L=20\text{mm}$, and thermal conductivity $k=200\text{W/m}\cdot^\circ\text{C}$. Heat is dissipated from the fin by convection into ambient air at $T_\infty=20^\circ\text{C}$ with a heat transfer coefficient $h_c=40\text{W/m}^2\cdot^\circ\text{C}$. If the fin base is at $T_b=150^\circ\text{C}$, calculate the fin into the ambient air.

A long, thin copper 6.4mm in diameter is exposed to an environment at 20°C . The based temperature of the rod is 150°C . The heat transfer coefficient between the rod and the environment is $24\text{W/m}^2\cdot^\circ\text{C}$. Calculate the heat given up by the rod.

A very long copper rod [$k=372\text{W/m}\cdot^\circ\text{C}$] 2.5cm in diameter has one end maintained at 90°C . The rod is exposed to a fluid whose temperature is 40°C . The heat transfer coefficient is $3.5\text{W/m}^2\cdot^\circ\text{C}$. How much heat is lost by the rod?

An aluminum fin 1.6mm thick is placed on a circular tube with 2.5cm OD. The fin is 6.4mm long. The tube wall is maintained at 150°C , the environment temperature is 15°C , and the convection heat transfer coefficient is $23\text{W/m}^2\cdot^\circ\text{C}$. Calculate the heat lost by the fin.

A straight rectangular fin of steel (1% C) is 2.6cm thick and 17cm long. It is placed on the outside of a wall which maintained at 230°C . The surrounding air temperature is 25°C , and the convection heat transfer coefficient is $23\text{W/m}^2\cdot^\circ\text{C}$. Calculate the heat lost from the fin per unit depth and the fin efficiency.

A triangular fin of stainless steel (18% Cr, 8% Ni) is attached to a plane wall maintained at 460°C . The fin thickness is 6.4mm, and the length is 2.5cm. The environment is at 93°C , and the convection heat transfer coefficient is $28\text{W/m}^2\cdot^\circ\text{C}$. Calculate the heat lost from the fin.

A 2.5cm diameter tube has circumferential fins of rectangular profile spaced at 9.5mm increments along its length. The fins are constructed of aluminum and are 0.8mm thick and 12.5mm long. The tube wall temperature is maintained at 200°C , and the environment temperature is 93°C . The heat transfer coefficient is $110\text{W/m}^2\cdot^\circ\text{C}$, calculate the heat loss from the tube per meter of length.

An aluminum fin 1.6 mm thick surrounds a tube 2.5 cm diameter. The length of the fin is 12.5 mm. The tube wall temperature is 200°C, and the environment temperature is 20°C. The heat transfer coefficient is 60 W/m²·°C. What is the heat lost by the fin?

A long stainless steel rod [k=16 W/m·°C] has a square cross section 12.5 by 12.5 mm and has one end maintained at 250°C. The heat transfer coefficient is 40 W/m²·°C, and the environment temperature is 90°C. Calculate the heat lost by the rod.

Steam in a heating system flows through tubes whose outer diameter is 5 cm and whose walls are maintained at a temperature of 180°C. Circular aluminum alloy 2024-T6 fins (k = 186 W/m·°C) of outer diameter 6 cm and constant thickness 1 mm are attached to the tube. The space between the fins is 3 mm, and thus there are 250 fins per meter length of the tube. Heat is transferred to the surrounding air at T_∞ = 25°C, with a heat transfer coefficient of 40 W/m²·°C. Determine the increase in heat transfer from the tube per meter of its length as a result of adding fins. *Answer: 2639 W*

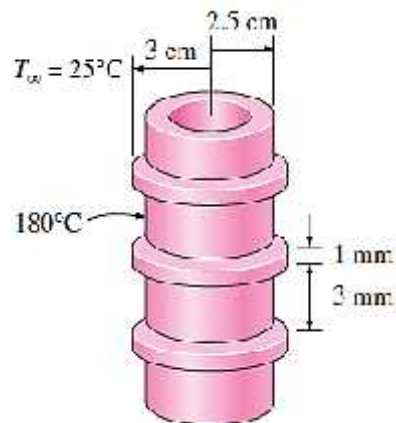

A hot surface at 100°C is to be cooled by attaching 3-cm-long, 0.25-cm-diameter aluminum pin fins (k = 237 W/m·°C) to it, with a center-to-center distance of 0.6 cm. The temperature of the surrounding medium is 30°C, and the heat transfer coefficient on the surfaces is 35 W/m²·°C. Determine the rate of heat transfer from the surface for a 1-m × 1-m section of the plate. Also determine the overall effectiveness of the fins.

