



REPUBLIC OF IRAQ
MINISTRY OF HIGHER EDUCATION
AND SCIENTIFIC RESEARCH
AL-FURAT AL-AWSAT TECHNICAL
UNIVERSITY
ENGINEERING TECHNICAL
COLLEGE- NAJAF



Optimization Technique Based on Genetic Algorithm for Cognitive Relay Networks

A THESIS

SUBMITTED TO THE COMMUNICATION TECHNIQUES
ENGINEERING DEPARTMENT

IN PARTIAL FULFILLMENT OF THE REQUIREMENTS FOR
THE TECHNICAL MASTER DEGREE

BY

Ban Khalid Ammar

(B. Sc. Communication Techniques Eng.)

Supervised by

Asst. Prof. Dr. Hayder Jawad Mohammed Al-Battat

Asst. Prof. Dr. Ahmed Ghanim Wadday

September 2019

Dedications

Gratefully dedicated to... my inspiration source, my first teacher, to my precious mother who leaved us so early...

To my beloved husband for his support and encouragement

To my dear brothers who supported me in very difficult days

Finally...to my lovely children who gave me hope and strength...

Acknowledgments

In the name of Allah, the Most Merciful, the Most Beneficent

I would like to thank the members of my supervisors Dr. Hayder Jawad Mohammed and Dr. Ahmed Ghanim Wadday, for the time and attention they have given to me.

Special thanks are for Mr. Mohannad Adnan Al-Ja'afari for his time, effort, and his guidelines that helped me at each step to complete the programming of my work.

Many thanks are for my entire family for their support, and for the people who are closest to me, especially thanks for my beautiful daughter Mina for her big helps.

Supervisor Certification

We certify that this thesis titled "**Optimization Technique Based on Genetic Algorithm for Cognitive Relay Networks**" which is being submitted by **Ban Khalid Ammar** was prepared under our supervision at the Communication Techniques Engineering Department, Engineering Technical College-Najaf, AL-Furat Al-Awsat Technical University, as a partial fulfillment of the requirements for the degree of Master of Technical in Communication Engineering.

Signature:

Name: **Asst. Prof. Dr. Hayder
Jawad Mohammed**

(Supervisor)

Date: / / 20

Signature:

Name: **Asst. Prof. Dr. Ahmed
Ghanim Wadday**

(Co-Supervisor)

Date: / / 20

In view of the available recommendation, I forward this thesis for debate by the examining committee.

Signature:

Name: **Dr. Salim Muhsen Wadi**

(Head of comm. Tech. Eng. Dept.)

Date: / / 20

Committee Report

We certify that we have read this thesis titled "**Optimization Technique Based on Genetic Algorithm for Cognitive Relay Networks**" which is being submitted by **Ban Khalid Ammar** and as Examining Committee, examined the student in its contents. In our opinion, the thesis is adequate for award of degree of Master of Technical in Communication Engineering.

Signature:

Name: **Asst. Prof. Dr. Hayder Jawad Mohammed**

(Supervisor)

Date: / / 20

Signature:

Name: **Asst. Prof. Dr. Ali Saeed**

(Member)

Date: / / 20

Signature:

Name: **Asst. Prof. Dr. Ahmed Ghanim Wadday**

(Supervisor)

Date: / / 20

Signature:

Name: **Dr. Asaad. S. Daghhal**

(Member)

Date: / / 20

Signature:

Name: **Prof. Dr. Mahmood Farhan Mosleh**

(Chairman)

Date: / / 20

Approval Dean of the Engineering Technical College- Najaf

Signature:

Name: **Asst. Prof. Dr. Hassanain Ghani Hameed**

Dean of Engineering Technical College- Najaf

Date: / / 20

Abstract

The Cognitive Relay Network is an emergent technology to deal with the scarceness and authority conditionality of frequency spectrum by dynamically assigning spectrum to unlicensed users with relaying. This new technology changes the model of conventional wireless system design by allowing unlicensed user with ability to sense, adapt and share the dynamic spectrum through relay nodes. The resource allocation (RA) of Cognitive Relay Network such (power allocation, sub-carrier allocation), interference management and relay selection are the important challenges because the adaption is operating under consideration of all constraints that prevent harmful the licensed user.

In this thesis, CRN models with an objective function of maximizing secondary users overall transmission rate are proposed. These CRN models adopted on OFDM as modulation scheme with multiple secondary users to enhance the spectrum efficiency, the model formulation schemes are supposed on a group of small cells within one macro cell in a heterogeneous cellular system with cross-tier interference.

Genetic Algorithm (GA) is used to solve the optimization problems. The results showed high ability of this algorithm to effectively determine the sub-channel (subcarrier) and power assignment, and increase the total capacity for the secondary network. The highest total transmission data rates obtained from these system models are (16.9715, 17.0391, 5.0686) bit/sec/Hz. The results are simulated by using the commercial package soft MATLAB 2018b.

Contents

Title	Page No.
Acknowledgements	I
Supervisors Certification	II
Committee Report	III
Abstract	IV
List of Symbols	X
Abbreviations	XIII
Chapter One: Introduction and Literature Review	
1.1 Overview of Cognitive Relay Network	1
1.2 Literature Review	2
1.3 Contributions	5
1.4 Thesis Organization	5
Chapter Two: Theoretical Background	
2.1 Cognitive Radio Network with Dynamic Spectrum Access	8
2.2 Dynamic Spectrum Access	8
2.2.1 Spectrum Management	9
2.2.1 Spectrum Sharing	10
2.3 Wireless Relay Concepts	12
2.4 Relay Functions	13
2.4.1 Decode and Forward (DF) relay	14
2.4.2 Amplify and Forward (AF) relay	14
2.4.3 Compress and Forward (CF) relay	14
2.5 Cognitive Relay Network	14

2.6 Orthogonal Frequency Division Multiplexing (OFDM)	15
2.6.1 Introduction to OFDM	15
2.6.2 OFDM Concept	16
2.6.3 OFDM Transmitter	16
2.6.4 Cyclic Prefix in OFDM	17
2.6.5 Mathematical Analysis of OFDM Transmitted Signal	18
2.6.6 OFDM Receiver	19
2.6.7 Application of OFDM to Cognitive Radio Net.	21
2.7 Resources Allocation for Cognitive Relay Networks	21
2.7.1 Resources Allocation Approaches	21
2.7.2 Resources Allocation Architecture	22
2.7.3 Resources Allocation Elements	22
2.7.4 Resources Allocation Strategies	23
2.8 Genetic Algorithm	24
Chapter Three: Optimization Techniques for Cognitive Relay Networks	
3.1 Introduction	26
3.2 System Model 1 : OFDM based- Cognitive (Two-Way AF) Relay Network	26
3.2.1 System Model	27
3.2.2 Rate Analysis for Secondary Network	29
3.2.3 Interference Analysis for Secondary Network	31
3.2.4 Problem Formulation	31
3.3 System Model 2 : OFDM based- Cognitive (One-Way AF) Relay Network	33

3.3.1 System Model	33
3.3.2 Rate Analysis for Secondary Network	35
3.3.3 Interference Analysis for Secondary Network	36
3.3.4 Problem Formulation	37
3.4 System Model 3:Interference Management for OFDM Based- Small Cells Cognitive Relay Heterogeneous Network	38
3.4.1 System Model	38
3.4.2 Rate Analysis for Secondary Network	41
3.4.3 Interference Analysis for Secondary Network	45
3.4.4 Problem Formulation	46
Chapter Four : Simulation Results and Discussion	
4.1 System Model 1	48
4.1.1 Simulation Results for System Model 1	48
4.1.2 Comparison Between The Results of System Model 1 and The System Model in [10]	54
4.2 Simulation Results for System Model 2	55
4.3 Simulation Results for System Model 3	60
Chapter Five : Conclusions and Future works	
5.1 Conclusions	68
5.2 Future Works	69
References	70

List of Symbols

Symbol	Definition	Unit
A_f	Amplification Factor	----
i	Subcarrier for MA phase	----
j	Subcarrier for BC phase	----
I_{th}	Interference threshold	Watt
K	Number of Relay nodes	----
N	Number of total Subcarriers	----
P_{max}	Maximum transmission power	Watt
P_{mBS}	Maximum Base station power	Watt
R	Transmission data Rate	Bit/sec/Hz
\mathcal{Z}	Cross-tier noise from MBS	----
n	Total noise is AWGN plus Cross-tier noise	----
Greek Symbols		
σ^2	Variance of AWGN	Watt
μ	Mean of AWGN	Watt

Abbreviations

Symbol	Description
A	Subcarrier Allocation matrix
AF	Amplify and Forward
AWGN	Additive White Gaussian Noise
B	Relay selection matrix
BC	Broad Cast phase
BW	Bandwidth
CR	Cognitive Radio
CRN	Cognitive Radio Network
CP	Cyclic Prefix
DFT	Discrete Fourier Transform
DSA	Dynamic Spectrum Access
FDM	Frequency Division Multiplexing
GA	Genetic Algorithm
HetNet	Heterogeneous Network
IDFT	Inverse Discrete Fourier Transform
i.i.d	Independent and Identical distributed
MA	Multi Access phase
MBS	Macro cell Base Station
OFDM	Orthogonal Frequency Division Multiplexing
PU _s	Primary Users
RA	Resources Allocation
SAN	Software Adaptable Network
SBS	Small cell Base Station
SDR	Software Defined Radio
SINR	Signal to Interference plus Noise Ratio
SNR	Signal to Noise Ratio
SSA	Static Spectrum Access
SU _s	Secondary Users
w	Watt

Chapter one

Introduction and Literature Review

1.1 Overview for Cognitive Radio Network

A simple definition of cognitive radio (CR) is a form of wireless communication in which a transceiver can intelligently detect which communication channels are in use and which are not, and instantly move into vacant channels while avoiding occupied ones. It is an intelligent radio that adapts its parameters as depending on the environment around it. Some of these parameters are: frequency of system operation, modulation type, transmission power and pattern of antenna beam. This adaptation depends on CR capabilities. CR has the ability to learn from its actions and back to this learning to decide the new actions in future [1], [2]. CR is equipped with hardware and software platforms depending on the software defined radio (SDR), but the cognition operation for awareness to its outer environments automatically. Figure 1.1 shows its components in a simple form (Mitola [3] for CR architecture). The concept of CR was first coined by Mitola with Maguire in 1999 [1]. CRN can be defined as a network that consists of multiple CR devices, and then the CRN has a software adaptable network (SAN) to adapt the network layers for its CR nodes. The main motivations of using the cognitive radio networks are to enhancement of the frequency utilization and to management of the resources efficiently [3].

The important problems or challenges of using CRN are: usage the frequency band efficiently by exploiting the vacant frequency band with the

resource allocation (subcarrier allocation and power allocation) and interference management to avoid the interference between users.

The first commercial application for cognitive network is IEEE 802.22 wireless regional area network (WRAN). It is used for the TV broadcast bands to exploit the white space in the TV bands [4], where this standard (IEEE 802.22) was first used in 2011[5].

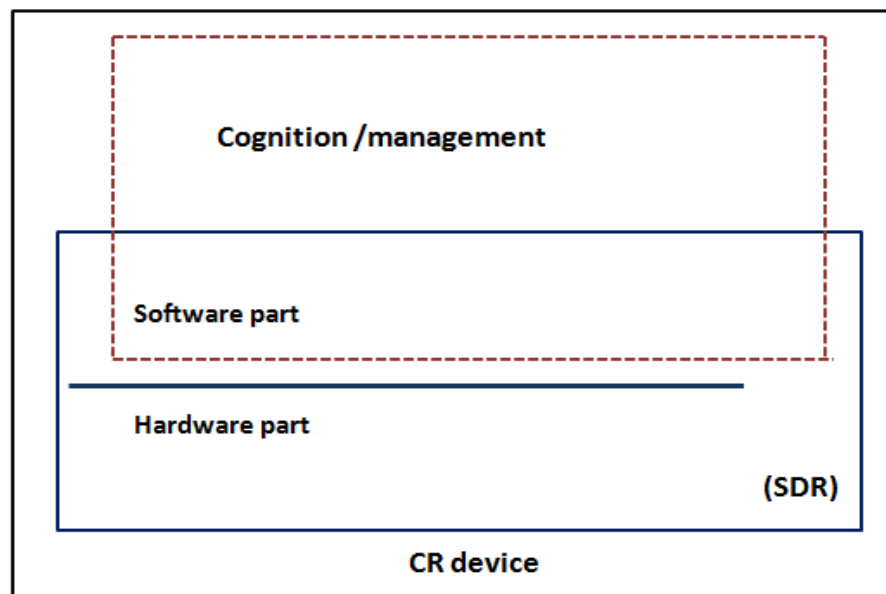

Fig. 1.1: The essential components for Cognitive Radio device

1.2 Literature Review

The main idea of CRN is that: allow the secondary users (SUs), also called unlicensed users, to exploit the unused spectrum bands owned by primary users (PUs), also called licensed users, by sensing and detecting the unused spectrum bands, also called (white holes), in the frequency spectrum band. In the concerning literature for this work, the resources allocation (RA) works (for power allocation and/or subcarrier allocation) for secondary users (SUs) and/or for relay nodes. Furthermore with or without relay selection for their systems, the constraints of (power and/or interference) are proposed for their works. In [6] the dual decomposition method was used as an optimization technique to

maximize the transmission rate under the power constraints to avoid the interference with primary user. And was used two activities: the subcarrier pairing (SP) to all the relays and joint power allocation. The destination received the signals from all relays not from specific relay; this is the difference with the other works. In [7] a genetic algorithm (GA) for suboptimal approach with the interference management was proposed. Moreover a dual decomposition and sub-gradient methods were used in order to solve issue of relay selection and RA of two-way relaying cognitive networks in the two protocols amplify and forward (AF) and decode and forward (DF) respectively. In [8] two activities for cognitive DF-relay network was presented, where a pairing of (subcarrier and power allocation) were arranged based-on-Genetic algorithm. In [9], a bandwidth product optimization metric was proposed. It used to achieve the optimal spectrum sharing for multi relays with DF protocol and used the Hungarian method for relay selection. The RA with perfect and imperfect sensing is proposed in [10] where a two-way multi AF relays to maximize the total data rate of the secondary network under the interference constraints were considered. Using three optimization techniques which are Lagrange dual decomposition, discrete searching, and Hungarian algorithm which used to achieve the subcarrier allocation, optimal power allocation and relay selection.

From the concept of CRNs, a group of small cells are used the license spectrum band owned by primary network or so called (macro cell). With a dynamic spectrum access (DSA) by spectrum sensing technique with hierarchical access model that preventing small cells to interference with macro cell under interference threshold. This is the simplest definition of Heterogeneous Networks (HetNet) [11]. To increase the coverage area between small cells and to help small cell users to communicate with each other, it is possible to propose the relay technique with small cells, within the macro cell [12]-[14]. In the related literature for this work, the HetNet consist from small cells (femto cell, micro cell, pico cell) within one macro cell. The proposed

heterogeneous model in [15] downlink transmission, using an OFDMA as a multiple access technique to limit the cross-tier and allocate a group of sub channels to different users same idea of cognitive radio, dual decomposition method used for power allocation and sub channels allocation. The authors in [16] proposed a new method for DSA for a hybrid-cognitive femto cell. The dual decomposition method was used to solve the problems of a power allocation and channel allocation there by, to maximize the total downlink rate. In [17] the optimal-power allocated has been solved by using a Lagrange method, where a MIMO femto cell was proposed with MIMO pico cell which shared the same frequency band with macro cell. In [18] two activity problems (the power and sub channel allocation) were solved by using a game theory to maximize the uplink transmission rate between a macro cell and multiple femto cells under the two-tier interference and delay for femto cell users. For power allocation problem in [19], it was solved by using proportional-integral (PI) controller (feedback closed loop) for OFDM femto cell with two-tiers.

The system model in this thesis is adopted based on reference [10], noting the main differences listed as follow:

1. In [10] a perfect and imperfect spectrum sensing were proposed, while this thesis is only addressed a perfect spectrum sensing method.
2. A genetic algorithm (GA) is used in this thesis to solve the suggested optimization problems; where as a three different methods (Lagrange dual decomposition method, discrete searching approach, and the Hungarian algorithm to obtain the optimal power allocation, subcarrier pairing matrix and relay selection matrix) were used in [10].
3. In [10], a step size has been used to find an optimal power through discrete searching method. In contrast in this thesis a maximum power is divided into 256 levels to give more flexibility of choosing a suitable power value.

The adopted system will be analyzed theoretically and then programmed using MATLAB in Chapter 3 and 4.

1.3 Contributions

The objective function of this thesis is to maximize the total transmission rate for secondary network. The main contributions of this thesis to improve system performance are:

1. Increase the total transmission data rate for secondary network, by using Genetic Algorithm which finds all calculations for the overall system models.
2. Cross-tier interference equations are calculated, and added with all calculations of $SINR$ to find the total transmission data rate for HetNet system model.
3. Giving more flexibility for power allocation which also leads to reducing the interference from SUs to PUs.
4. Getting higher total transmission data rate, when the value of interference threshold decreases.

1.4 Thesis Organization

Chapter 1: This chapter introduces an introduction to CRN, simple architecture, the first application for CRN, related literature review, main motivations and contributions of this thesis.

Chapter 2: This chapter presents in detail all issues related to this thesis, starting with an overview of CRN and how to exploit the spectrum through DSA, the relay technology, OFDM, then all classifications for RA that used in this thesis for cognitive relay network, and the GA.

Chapter 3: This chapter includes the adopted system models. Through this chapter three system models are introduced, for each model: system model description, rate and interference analysis are presented.

Chapter 4: This chapter discusses and views all the results for the three system models in chapter three including: the subcarrier-pairing matrix, relay selection matrix, all power allocation for each SU_s and each relay node, signal to noise ratio SNR formulated for optimizing the channel efficiency of each relay node, and then the overall transmission data rate.

Chapter 5: It includes the conclusion for the results in this thesis and the new ideas for research suggestions that proposed in the future.

Chapter 2

Theoretical Background

2.1 Cognitive Radio Network with Dynamic Spectrum Access

The main idea of CR technique is that the capability of this technique to sharing the spectrum band among PUs and SUs). It is allowing the SUs to benefit from the unexploited spectrum by the PUs, or so called (white gaps), through sensing the vacant bands in the spectrum with consideration of some interference limitation from SUs to PUs.

To access these holes dynamically by Dynamic Spectrum Access (DSA) technology, all this is explained in details in the next part.

Spectrum sensing is an important step in the cognitive radio network since the vacant spectrum can be exactly detected. Depending on this step, cognitive radio network has the capability to adapt its parameters according to the unlicensed spectrum properties (for example: modulation type, power value, frequency type) and when it is back to its licensed spectrum, the network will return to its parameters [20]. Figure 2.1 illustrates the cognitive radio cycle adopted from [1], [2]:

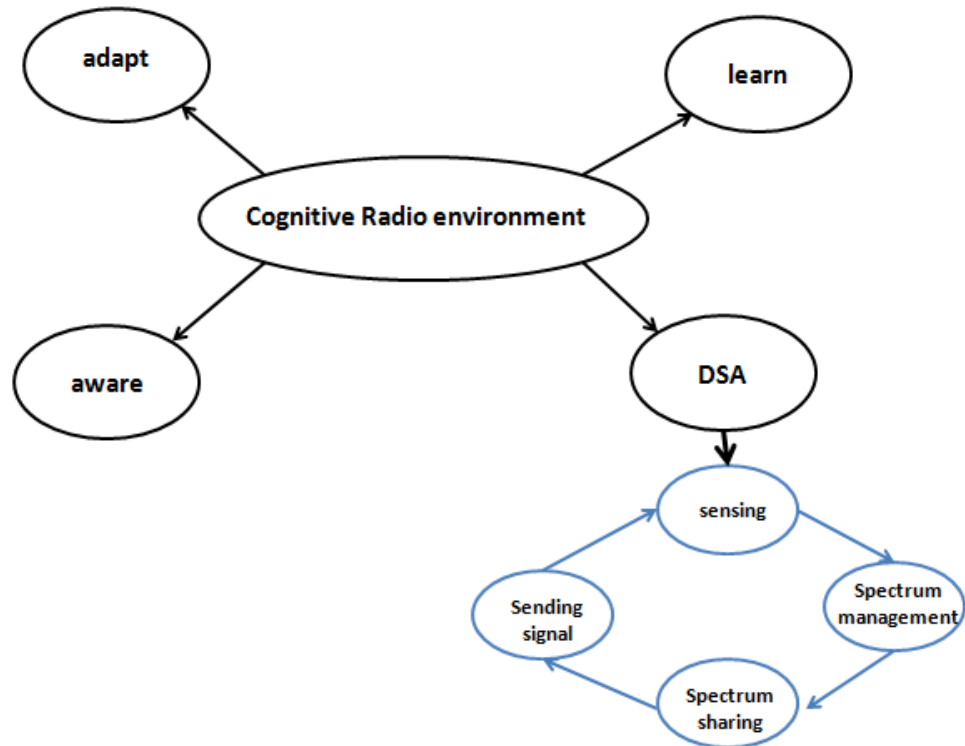

Fig. 2.1: Cognitive Radio Cycle

2.2 Dynamic Spectrum Access (DSA)

Instead of using a fixed spectrum bands in a static spectrum access (SSA), cognitive radio is introduced to repeat the searching of the white hole or unused spectrum bands periodically. This is the meaning of dynamic spectrum access (DSA). In DSA, spectrum management is based. The SUs can sense the spectrum band (owned by PUs) to find the unused spectrum bands that are unoccupied by PUs, then sharing them among the SUs, with the all constraints must be under threshold level are considered, to prevent the interference from SUs to PUs. With DSA, the cognitive radio network uses the spectrum band efficiently to enhance the spectrum utilization. Figure 2.2 demonstrates the idea of cognitive radio for spectrum holes concept [21].

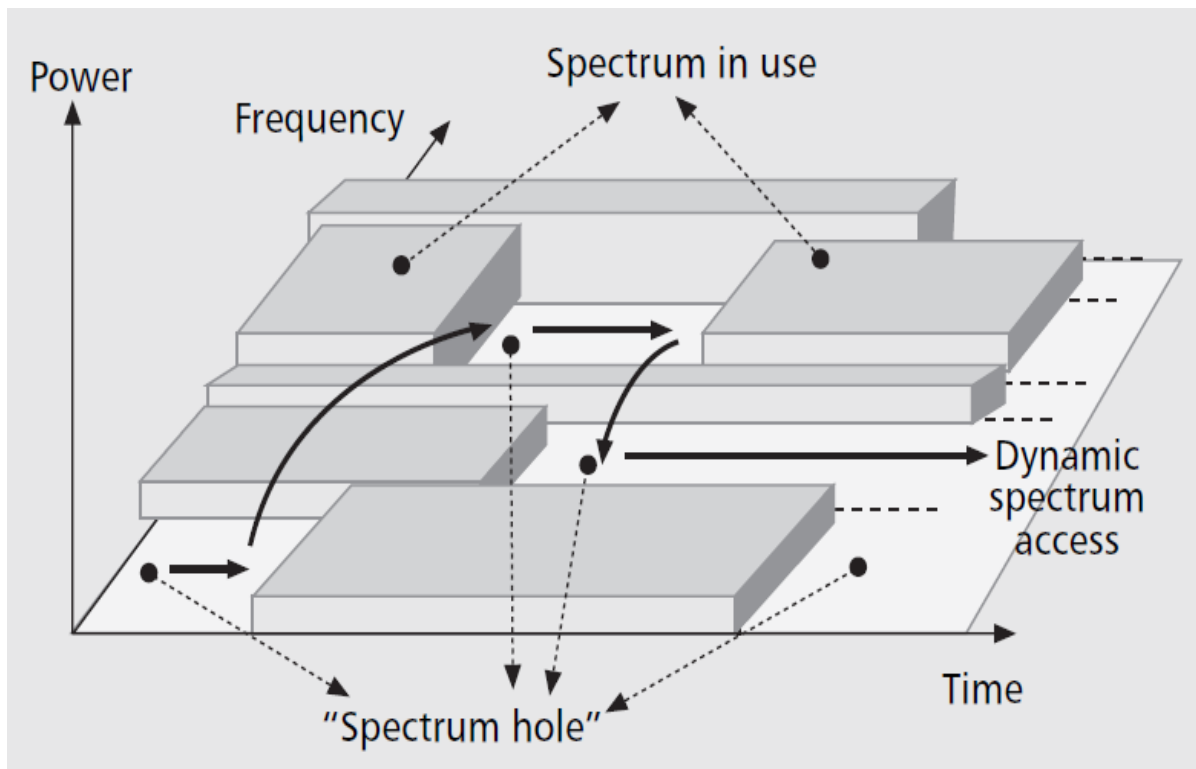

Fig. 2.2: The idea of Cognitive Radio with DSA

2.2.1 Spectrum Management

Cognitive radio technology enable SUs to detect the unused licensed spectrum bands to determine which portions are not occupied by licensed users (PUs) to avoid the interference to PUs and exploit the vacant spectrum bands. This describes the spectrum management for cognitive radio by four steps [21], [22]:

1. Spectrum sensing: This is an important step because SUs can detect the spectrum holes in time and frequency domain, without any harm to primary users. In this step cognitive radio detects only the vacant spectrum bands that are unused by the primary users.
2. Spectrum decision: to select the best spectrum band that matches with user communication requirements over the all available spectrum bands.
3. Spectrum sharing: coordinates the access to this spectrum bands with other users.

4. Spectrum mobility: in this step, the cognitive user must search other spectrum bands by sensing the spectrum again, if primary users appear and want to use the same portion of spectrum bands.

Figure 2.3 illustrates the four steps for spectrum management, adopted from [23].

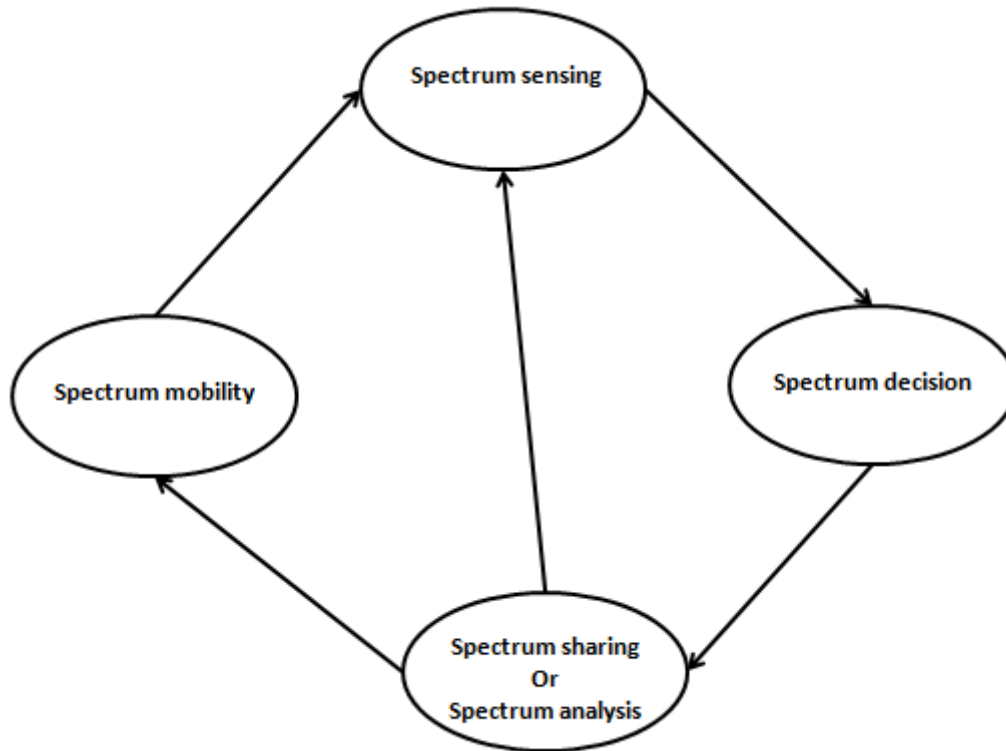

Fig. 2.3: The main steps of spectrum management

2.2.2 Spectrum Sharing

Also called spectrum access paradigm, after the spectrum sensing and detecting the white holes, the access from secondary users with primary user must be controlled to avoid the interference with the primary user. There are three types of spectrum access paradigm [24]:

1. Overlay paradigm: in this type, the SUs use the vacant band and transmit the signal simultaneously with PUs, and the primary user has the priority to use that spectrum. This paradigm controls the interference with PUs by using an

advanced coding technique. (The SUs and PUs are sharing the spectrum and sending at the same time).

2. Underlay paradigm: in this type, the SUs use the frequency band simultaneously with the PUs, but with interference threshold and low transmission power with power constraint, to avoid any interference with PUs. (The SUs and PUs are sharing the spectrum and sending at the same time).

3. Interweave paradigm: in this paradigm, the SUs can use the spectrum holes only if the primary user does not transmit. (The SUs and PUs are sharing the spectrum and sending not at the same time).

In this thesis the Underlay paradigm is adopted. Figure 2.4 shows the overlay and underlay paradigms [1].

To increase the coverage area among the SUs, and to assist the SUs to communicate with each other with lower transmission power, it is possible to propose a relay technique combined with the SUs within the cognitive radio network [10]. The relay technique explained in detail in the next part.

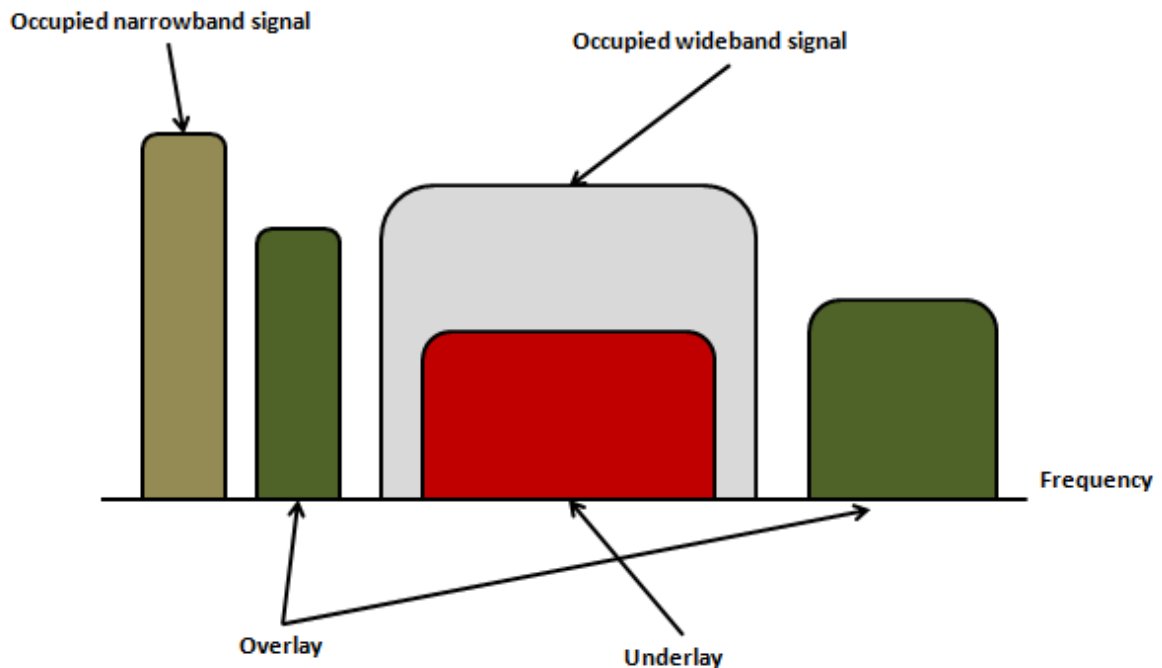

Fig. 2.4: The spectrum access paradigms

2.3 Wireless Relay Concept

The main concept of relay nodes is to assist the transmitter to communicate with the destination. This idea was first coined by Edward C. Van Der Meulen [25]. In the beginning of using relay in communication, it is capable of operating in a full-duplex mode (FD). The drawback of this mode is that the relay device will transmit and receive the signals on the same frequency band which introduces the interference called self-interference. In addition, the power values from the transmitter and the receiver are different in levels. Therefore, the half-duplex mode is considered better than a full-duplex mode since it operates in different bands for transmitter and receiver which imply to eliminate the self-interference and separating between transmitted and received signals. When a direct link between the source and the destination is available, and the relay node also available as intermediate node between the source and destination, is introduced a cooperative relay protocol (orthogonal and non-orthogonal), and the received signals at destination will be from two paths (from direct link and from relay node). In orthogonal protocol, the source node (S1) transmits the signal in the first phase to relay node and to destination node (S2), in the second phase the (S1) will be silent and the relay node only transmit the signal to (S2). In non-orthogonal protocol, (S1) transmits the signal in the first phase to relay node and to (S2), in the second phase the (S1) continuously transmitted in addition to the relay node also transmitted the signal to (S2). Therefore, the non-orthogonal protocol is more challenging than orthogonal protocol, since it combined between direct link and orthogonal protocol. Relay protocols are classified into one-way and two-way (bidirectional relay) to exchange messages between source and destination. One-way protocol takes four phases to complete the message exchange: (the first phase from source node (S1) to relay node; the second phase from relay node to destination node (S2); the third phase from destination node (S2) transmit to relay node; and the fourth phase from relay node to source node (S1)). Two-way protocol either takes three phases or takes two phases. In two-way with three phases, the source node (S1) transmits in first

time slot to relay node. The destination node (S_2) transmits to relay node in the second phase. The relay node in the third phase transmits to (S_1) and (S_2) at the same time. In two-way with two phases, the (S_1) and (S_2) nodes transmit to relay node in first phase and in the second phase the relay node transmits to S_1 and S_2 nodes [7], [26] and [27], Fig. 2.5 demonstrates some of half-duplex protocol schemes [26].

2.4 Relay Functions

The main benefit of the relay node is to assist the source and the destination to communicate with each other in low transmission power. It has also offered three types of relay: Decode and Forward (DF), Amplify and Forward (AF) and, compress and forward (CF), according to relay functions [7], [26].

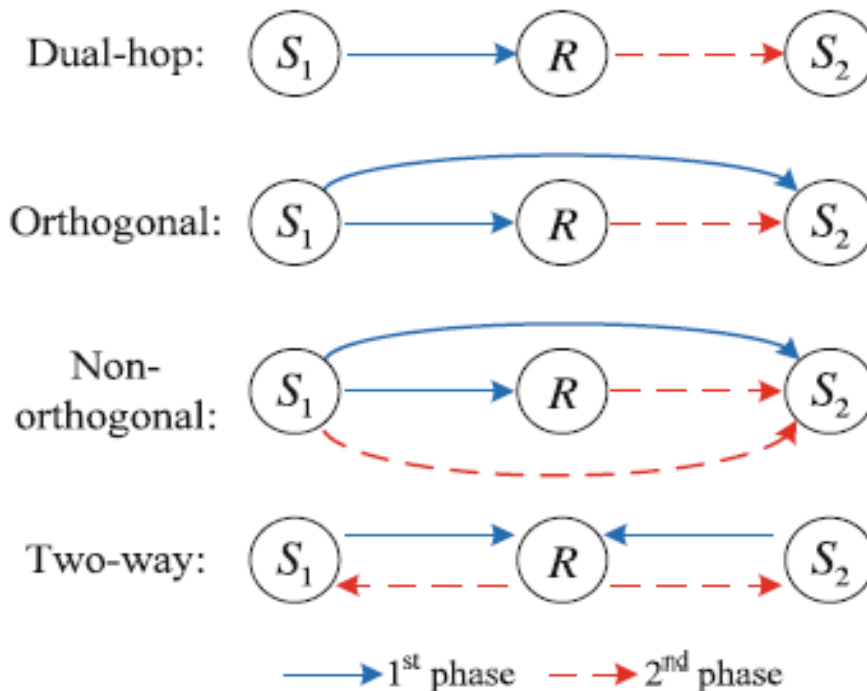

Fig. 2.5: Half-duplex protocols: dual-hop (one-way but into two phases), orthogonal and non-orthogonal (cooperative relay protocol), and two-way protocol

2.4.1 Decode and Forward (DF) relay: in this type the relay decodes the received signals from source nodes and encodes the signals then forward them to the destination nodes.

2.4.2 Amplify and forward (AF) relay: in this type the relay only amplifies the received signals from source nodes with amplification factor, then forward the signals to the destination nodes, the AF relay is simplest and has a low delay from DF.

2.4.3 Compress and Forward (CF) relay: in this type the relay compresses the received signals and forward them to destination node [26], [28], [29], CF relay quantizes the received signals, and then decodes the quantized bits before forwarding them to destination nodes [30].

The AF amplifies and forwards the received signal in addition the noise signal, DF encoded the received signal in addition the noise signal. In the CF is better because it compresses the signals and the noise signal since it eliminates the noise signal which received at the receiver [28]-[30].

The AF relay is simple and practical to implement, lower computational complexity and has less delay in the relay terminal. Therefore, the relay node is adopted in this thesis (two-way AF) with two phases.

2.5 Cognitive Relay Networks

Depending on all sections mentioned above about cognitive radio technique and relay communication technology, the combination of cognitive radio and relay techniques gives advantages to these techniques [31]. A combination of this cooperative work has an important role in advanced communication systems, where the relay nodes assist the secondary users to communicate with each other. Some of the cognitive relay combination advantages [32] - [34] are:

1. Enhancing the frequency band efficiency.
2. Expanding the coverage area.
3. Eliminating the transmit power for SUs.

4. Improving spectrum utilization.
5. Helping to increase the total capacity for the network.

Secondary users (one SUs pair or multiple SUs) communicate with each other over relay nodes. In the concerning studies suggest using one rely node and/or multiple relay nodes to help secondary users. Some other concerning studies propose the type of relay mode, the type of rely, and the type of communication protocols [7], [9], [35]-[39].

In this thesis the OFDM modulation technique is adopted for cognitive relay network, due to the advantage of subcarrier allocation. In addition to the advantage of the orthogonality to limit the inter-carrier-interference subcarriers [10], [40] OFDM techniques are explained in detail in the next part.

2.6 Orthogonal Frequency Division Multiplexing (OFDM)

2.6.1 Introduction to OFDM

In high data rate transmission of wireless systems, the total bandwidth will be larger than the coherence bandwidth ($BW \gg W_c$) in a frequency domain, meaning that the total time of transmission symbols be smaller than the time delay in wireless channel ($T_s \ll T_d$). This leads to a problem known as inter-symbols-interference (ISI), (the time delay due to the spreading out for the act of reaching destination time from multi path, called frequency selective fading) [42].

The parallel transmission data rate firstly back to 1950s [41]. In this transmission technique, the total bandwidth of frequency is divided into numbers of smaller subcarrier bands (N) where each has a part of bandwidth equal to (BW/N) . This technique is defined as frequency division multiplexing FDM. The main disadvantage of using FDM is that it needs a guard band between the subcarriers to avoid the interference between them.

The developed idea of FDM is proposed in mid-1960 [41]. It is the same idea of frequency division technique but without using the guard band. On the contrary, these suppose the overlap between the subcarriers on the frequency

domain. This developed technique is defined as orthogonal frequency division multiplexing (OFDM). This technique has effectively increased the spectrum efficiency with the increasing of the total bandwidth by using the orthogonality property between the subcarriers.

The total bandwidth BW will be divided into N subcarriers, each subcarrier has a data rate equal to (BW/N) and each will transmit a group of data symbols. Then the total bandwidth will be decreasing by N , that leading the total bandwidth to become smaller than the coherence bandwidth ($BW \ll B_C$), in addition the time of each subcarrier is equal to (N/BW) will be larger than time delay of wireless channel ($T_S \gg T_d$) that lead to no ISI [41], [42].

2.6.2 OFDM Concepts

In OFDM, keeping the concept of transmitting a high data rate is by dividing the total bandwidth into N subcarriers with a smaller bandwidth, which each has a band (BW/N) . In OFDM, instead of using multi-oscillators to generate N subcarriers, in 1971 Weinstein and Ebert proposed a mathematical technique of using the Inverse Discrete Fourier Transform (IDFT) to generate the N subcarriers (that are orthogonal on each other in a frequency domain without the need to add a guard band) and convert them from frequency domain to time domain. Figure 2.6 depicts the difference in using a bandwidth between FDM and OFDM [41].

2.6.3 OFDM Transmitter

Firstly, the high data rate of a stream symbols input to a (serial-to-parallel) converter to divide the total band in serial form to N smaller band sub-stream in a parallel form, each sub-stream band is equal to (BW/N) . Then, these N sub-streams are inputs to the IDFT to transform the sub-streams from frequency domain to a pulse form in time domain. After IDFT, the N sub-streams go to the (parallel-to-serial) convertor to put and send them in a serial form. The output is defined as an OFDM- symbol block. The data symbols are generated originally

in a frequency domain, and are carried by the peak of sync function. That meaning in the necessary the zero crossing of the subcarrier must be across at the peak of the other adjacent subcarrier, because in the receiver the symbols data will be recovered from the peak of subcarriers in a frequency domain [42].

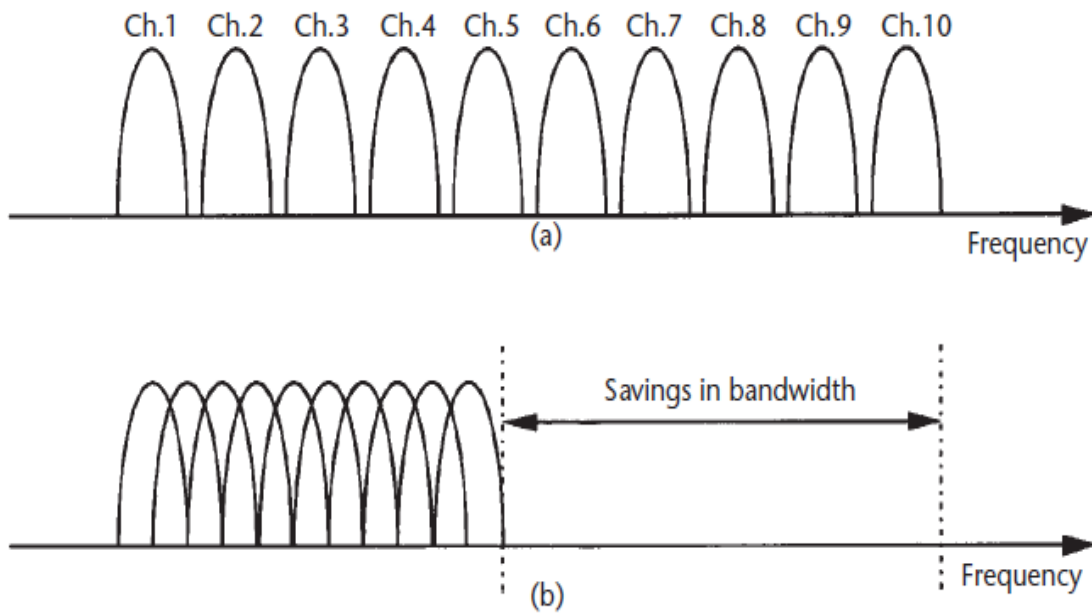

Fig. 2.6: The difference between the FDM technique with additional band needed and the OFDM that efficiently saved a bandwidth

2.6.4 Cyclic Prefix in OFDM

The OFDM symbols or blocks from the OFDM transmitter will transmit one after one directly, due to the multipath. The OFDM blocks will interfere with each other in a time domain. This is called an inter-block-interference (IBI), but there is no interference between symbols inside each block. To eliminate the interference between the adjacent OFDM blocks, the guard time is added between them in a time domain. Practically the additional (g) symbols are added at the beginning of each symbols after IDFT operation, then the symbols inside OFDM block will be $(N+g)$, the extra symbols are also known by the cyclic prefix [42].

2.6.5 Mathematical Analysis of OFDM Transmitted Signal

The analysis for OFDM signal is at specific time (T) which is the time of OFDM block equal to the time of OFDM symbols plus the time of guard symbols (T_S+T_g). The high data rate symbols are the input to a serial-to-parallel convertor to separate them into N low data rate sub-stream symbols X_N . This N symbol goes to k -point of IDFT to convert this data from frequency domain to its corresponding time domain $x_{(n)}$ in Eq. (2.1) (because the original data is generated in a frequency domain). After that, the guard symbols are added and inputted to a parallel-to-serial convertor, to converting them into a serial form in time domain. A digital-to-analogue convertor is applied to convert the multicarrier stream from a digital form to its corresponding analogue form $x_{(t)}$ in Eq. (2.2). Determining a specific symbols at a time T by multiplying a part of this stream $x_{(t)}$ with a rectangular function ($\text{rect}(t) \cdot e^{-j2\pi f t}$), where the multiplication operator in a time domain is equivalent to a convolution in frequency domain between the multicarrier and sinc function takes a $2/T$ time. Figure 2.7 shows the convolution to introduce the multicarrier [42], where, the number of N symbols equals the number K points of IDFT.

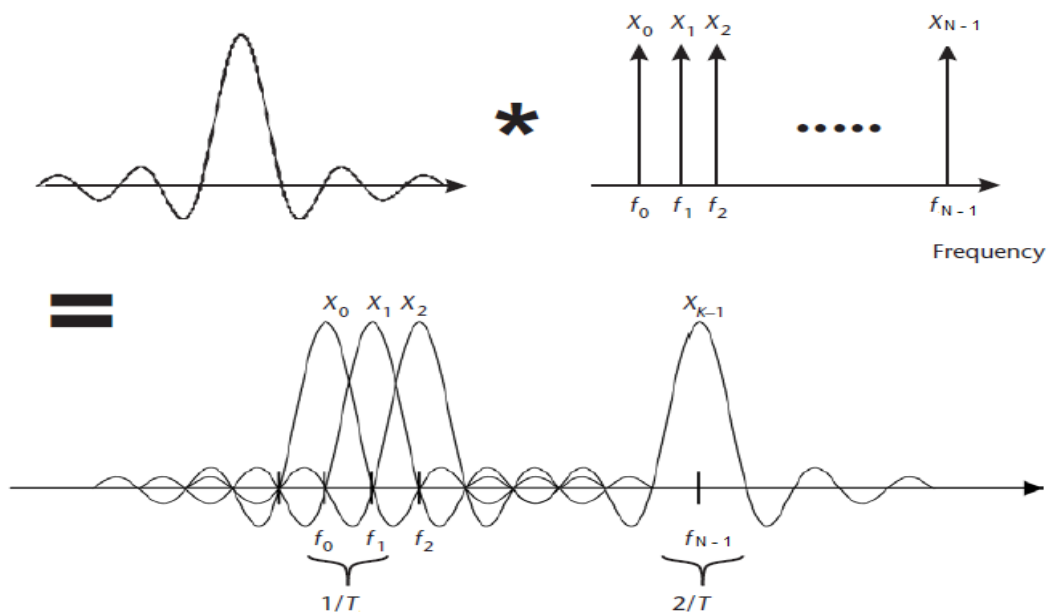

Fig 2.7: The Convolution in frequency to introduce the multicarrier

$$x_{(n)} = IDFT \{X_N\} = \frac{1}{N} \sum_{k=0}^{N-1} X_k \cdot e^{j2\pi \frac{k n}{N}} \quad (2.1)$$

$$x_{(t)} = \frac{1}{N} \sum_{k=0}^{N-1} X_k \cdot e^{2j\pi \frac{k}{T} t} \quad (2.2)$$

Where, $f_k = \frac{k}{T}$ is a substitution the carrier frequency by a corresponding time of OFDM blocks that is equal to the time of rectangular function, and N is a sample in a time T , then $n T \rightarrow n = \frac{N}{T} t$. In OFDM signal, each group of symbols is between two high power subcarriers, called the pilot subcarrier. The pilot subcarrier carries information signals to help the receiver to estimate that symbols are actually sending on their corresponding channel [42].

2.6.6 OFDM Receiver

At the receiver, the original data symbols can be recovered from the peak of each subcarrier, where the recovered is data symbols in the frequency domain.

The peak of each subcarrier has exactly to be across with a zero-crossing of the other adjacent subcarriers. To avoid the Doppler shift (frequency dispersion) due to the frequency offset caused by the motion between the transmitter and receiver (required time selective channel), requires precisely the peak of each subcarrier occur with a zero crossing with the others.

The OFDM symbols or block goes to OFDM receiver, firstly pass into the low-pass-filter (LPF) to get the analogue baseband signal in the time domain, then multiply it by complex conjugate of rectangular function, to convert it from continuous in time to discrete in time by using analogue to digital converter (ADC). After that it goes to S/P convertor to convert this stream of discrete symbols into groups of symbols consisting of N and g , and then the cyclic prefix (CP) is removed before DFT.

To return back the received symbols from time to frequency domain, the symbols then input to DFT to get the discrete symbols in frequency. Each symbol then goes to its equalizer and its detector to cancel the influence of the channel (channel distortion) on the symbols and to sure an each symbol is actually carried by its corresponding subcarrier.

Each data symbol in low data rate returns to its origin form finally, all low data rate symbols are gathered by inputting them to the P/S convertor to get the high data rate in frequency domain [42]. Figure 2.8 shows the OFDM transmitter and receiver [43].

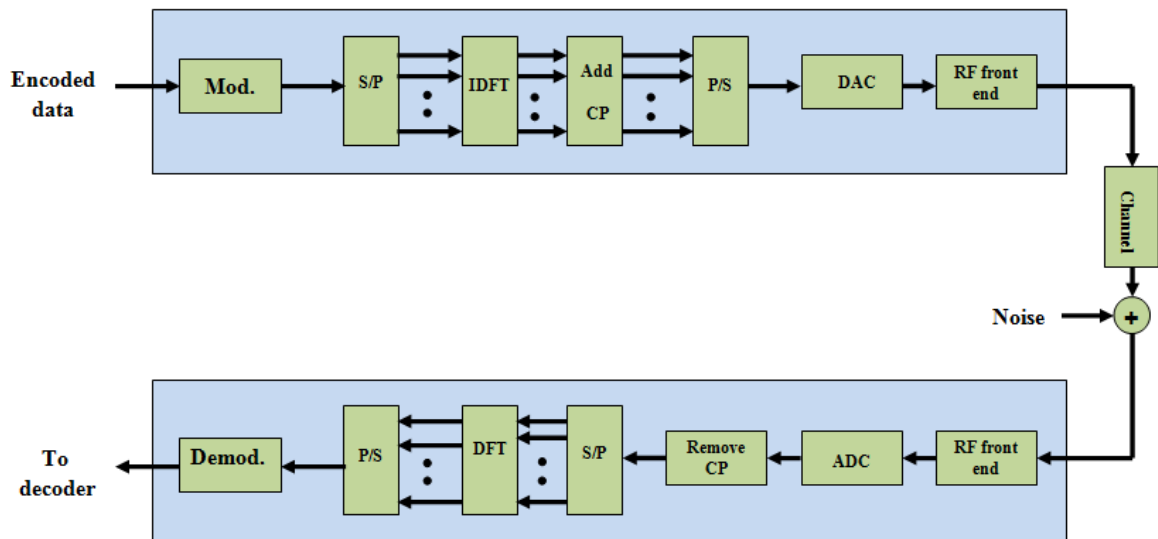

Fig. 2.8: OFDM Transmitter and Receiver

The DFT equation to convert discrete time symbol to its equivalent in frequency in Eq. (2.3) below:

$$DFT\{x_{(n)}\} = X_k = \sum_{n=0}^{N-1} x_{(n)} \cdot e^{-2j\pi\frac{k}{N}n} \quad (2.3)$$

2.6.7 Application of OFDM to Cognitive Radio Network

The OFDM is applied to CRN since it has the good benefits for this network [43]. Some of these benefits are:

1. Spectrum sensing in frequency domain is easy, due to the DFT technique is built-in OFDM.
2. Parameters adaptation, because the OFDM can easily adapt its parameters according to different environments. Some of these parameters include type of modulation, transmission power for subcarriers, size of DFT and CP and spacing between subcarriers.
3. Spectrum utilization efficiently, where the signal is shaped according to the vacant subcarriers by turning off the occupied subcarriers used by primary user.
4. Other advantages are MIMO antenna and spectrum allocation for multiple users, because OFDM is easy to access support multiple access.

2.7 Resource Allocation for Cognitive Relay Networks

Resource Allocation (RA) play a significant role in exploiting the spectrum underutilization in cognitive relay network, through allowing the secondary users the opportunity to access the licensed band without harmful the primary users. RA can be classified into four types:

2.7.1 Resource Allocation Approaches

In this classification, RA uses two approaches to solve the problem, which are the centralized and distributed. In centralized approach, one node such base station (BS) is central node that collects all information about the network and sends the control signal to all users. One major problem in this approach is that if the central node fails, this leads to frailer network too. But this approach is suitable in high-load network. The distributed approach is more flexible than the central approach since each user can collect network information by itself or by cooperating with a cooperation node or with adjacent users, leading to more

flexible adaptation according to the variations in the network. This approach is suitable for low-load networks [44].

2.7.2 Resources Allocation Architecture

This classification is according to the model of the network, infra-structure and Ad-hoc models. In infra-structure there are a number of users connected to one BS. The central approach is used in this model to implement the central structure. BS can protect primary users in this model when secondary users use the spectrum with resource allocation in cognitive networks. The Ad-hoc model is different from the infra-structure model, there is no BS in this model and the communication between users is direct with each other. It is either single or multi hop where the distributed approach is used in this model [44].

2.7.3 Resource Allocation Elements

The elements of RA are classified according to the objective problem. Some targets of optimization or constraint that accompany the resources allocation problem are [44], [45]:

1. Maximization throughput or sum-rate: this is a general target of RA problem, proposing maximization throughput for one user or sum rate for all secondary and primary users in the network.
2. Power allocation: the challenging of power allocation in cognitive network must be under acceptable level to avoid the interference from SUs to licensed users.
3. Relay selection: the relay nodes in cognitive network can help efficiently the power allocation to decrease for SUs and the best relay that helps the SUs to communicate with each other from allowing the receiver user to receive information from another relay if the relay in the deep fades.
4. Sub-carrier allocation: The subcarrier allocation or subcarrier pairing is important in cognitive networks that utilize the OFDM.

The other elements will be shown in the Fig. 2.11

2.7.4 Resources Allocation Strategies

There are several classification algorithms according to the strategies to solve the objective problems [44], [46]:

1. Heuristic: for a certain problem it is very difficult or impossible to obtain the optimal solution in some cases. Simplifying the system structure and finding the optimal solution for the new structure is the manner of this strategy. There is no fixed method for heuristic. For generating a method or a technique for the system structure this depends on the study of the problem.
2. Optimization: this is for all solutions. Optimization problems search the optimal of all possible solutions, which is either minimizes or maximizes a certain objective function. Some of the objective functions are: min-transmission power, max-sum rate, max-capacity, max-spectrum utilization and max-channels utilization. The constraints in the optimization technique are: power and interference constraints. All resources of classifications are depicted in Fig. 2.11 [44].

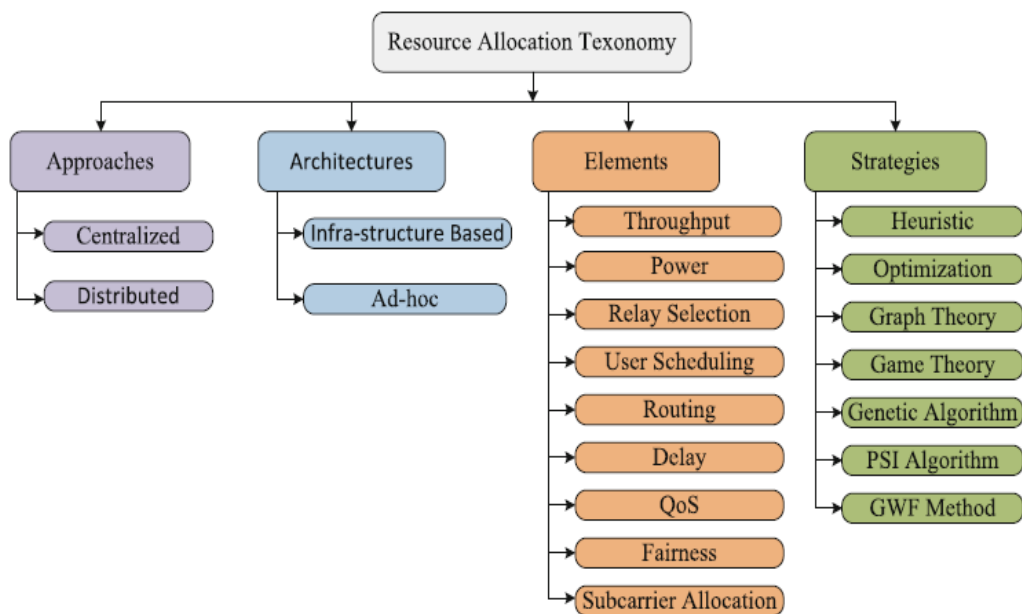

Fig. 2.9: Classification of Resources Allocation with all elements, strategies or techniques

2.8 Genetic Algorithm

In this thesis, genetic algorithm (GA) is adopted to find the objective function which is: maximization of the total transmission rate for secondary network, and solving three optimization problems (power allocation, subcarrier allocation and relay selection) with the consideration of all constraints.

In 1975 [47] John Holland applied the natural selection to optimization problems from the concept of "Survival of the Fittest". From this approach, the steps of GA were proposed. Which are listed as follow [47], [48]:

1. The initial population is generated at first randomly according to the fitness problem (objective function), where each individual of these populations is called parent. Each parent acts as a vector, called chromosome, to have a number of genes (formulation problems).

GA selects which of chromosomes are particular chosen to generate a new generations by a selection process (roulette wheel selection method), many selection technique use a selection roulette methods, in this method the selection process based on probability.

2. Crossover and mutation operations are applied between the initial populations (parents) to create new generation (children).

The new generation has some parts of its parents, cross over operation take points in a new generation, if takes one-point that meaning the new generation cross the two chromosomes parents in one points (takes two parts one from parents1 and the other from parent2), the other types are (two-points, three points or more).

The mutation process is a random process, where any gene is replaced by another gene in a new generation, it applied by a low probability take a range from 0.001 to 0.01

3. The children of the next generation are chosen according to the fitness problem.

4. The crossover is applied to generate a new generation. This operation will stop if a best fitness is given a value or the generation size reaches to a maximum number.

Genetic Algorithm is used to solve multi optimization problems and to give best solutions to fitness functions for the systems that change frequently in nature[47]. GA flow chart is shown in Fig. 2.12 [49].

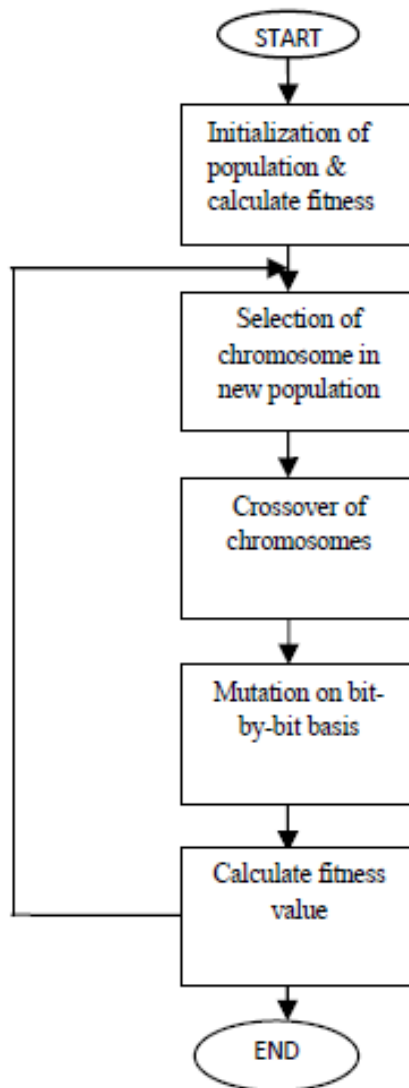

Fig. 2.12: GA flow chart

Chapter 3

Optimization Techniques for Cognitive Relay Networks

3.1 Introduction

Due to increasing the demand on the spectrum through the rapid progress in telecommunication technologies, the capacity improving, radio resource allocation and interference management are considered for this development. Cognitive relay network (CRN) is a combination between two significant techniques (CR and RN techniques) which can be supposed as a best elucidation for spectrum band utilization task. Optimization of the total transmission rate for the cognitive relay network is the objective function in this chapter. The optimization problems adopted in this chapter are: power allocation, subcarrier allocation, with relay selection for underlay OFDM-CRN assistance by one-way and two-way, AF relay nodes.

In this thesis the GA is adopted to solve the entire optimization problems to maximize the total transmission rate for the secondary users. GA shows its capability to generate all the variables used to find the maximum transmission rate.

3.2 System Model 1: OFDM based-Cognitive Two-Way AF Relay Network

In this model, OFDM system based on cognitive radio network with half-duplex two-way AF relay network and perfect spectrum sensing is adopted. GA is used to maximize the total transmission rate, with the power allocation, subcarrier allocation, and relay selection.

3.2.1 System Model

In this model, one primary user pair (source and destination) PU_s and PU_d shares the license band with the other users, called the SU_s , where $\mathcal{S}_s \in \{SU_1, \dots, SU_a\}$, the symbol (a) refers to number of secondary users. The relay node is denoted as R_k , $\mathcal{K} \in \{1, 2, \dots, k, K\}$ is refer to the total number of relay nodes which used to assist the secondary users communicating with others. The overall spectral sub-bands maintained by the licensed user are divided into sub-channels equal to N subcarriers of OFDM. The subcarriers occupied by the licensed user are defined by the set N_o , and the unused subcarriers or vacant are allocated to secondary network defined by the set N_v . The elements of the variables which used in this system model are listed in table 3.1, where the system model is shown in Fig. 3.1, and all the system definitions are shown in Table 3.2. It is important to state that the total spectrum band owned by the PU shares it with secondary network (consisting of SU and relay nodes). This is divided into a specific number of subcarriers N ($N = 6$).

Table-3.1: System variables

SU_s	$\{SU_1, SU_2\}$
R_k	$\{R_1, R_2\}$
N	$\{1, 2, 3, 4, 5, 6\}$
N_o	$\{1, 2\}$
N_v	$\{1, 2, 3, 4\}$

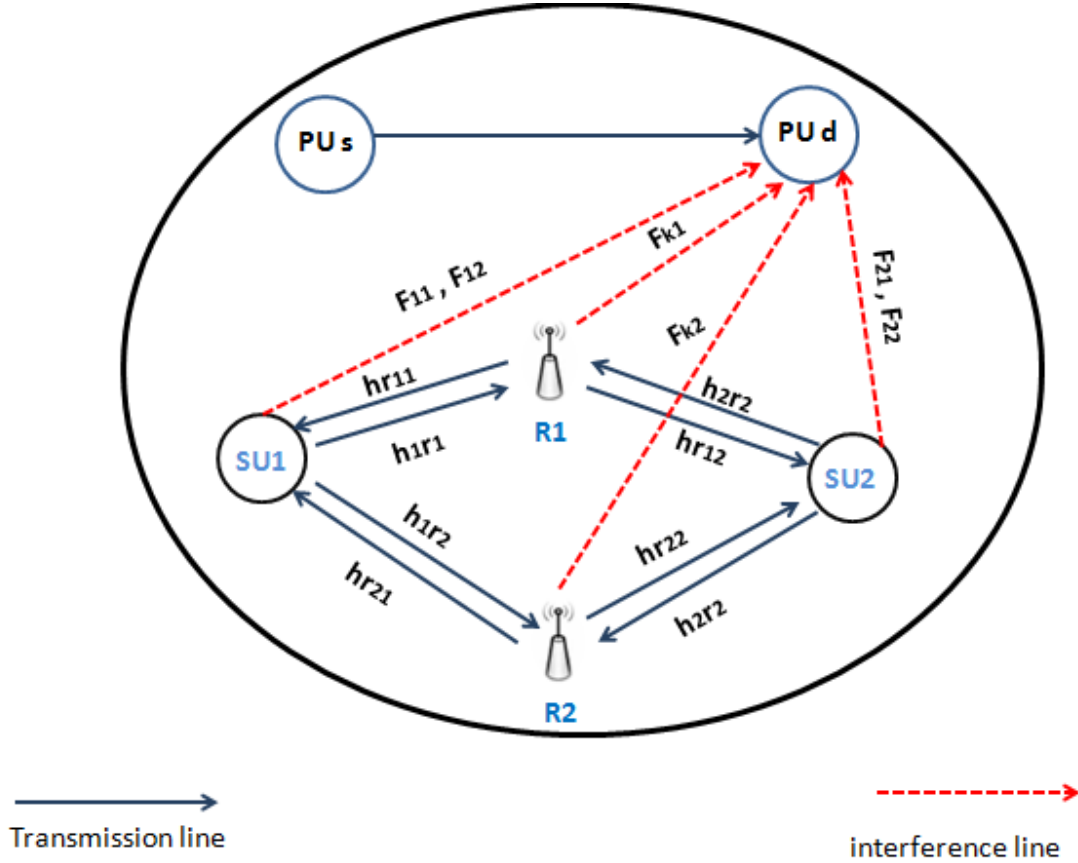

Fig. 3.1: System Model 1

Table-3.2: System Definitions for System Model 1

i	Subcarrier index for MA-phase from (SU_s) to relays. $i \in N_v$.
j	Subcarrier index for BC-phase from relays to (SU_s). $j \in N_v$.
x_{si}	Describe the transmitted symbols from SU_s through subcarrier i .
p_{si}	The power allocated to the SU_s when are sending to k^{th} relay on MA-phase.
$h_s r_k$	Represent the channel-gains when the SU_s are sending to k^{th} relay on MA-phase.
hr_{ks}	Represent the channel-gains from k^{th} -relay to the secondary users on BC-phase.
p_{kj}	The allocated power to k^{th} relay when it sending to secondary user on BC-phase.
F_{sq}	Represent the interference-channel gains from secondary users on MA-phase to primary users on subcarrier q , when SU_s transmits to relay nodes ($q \in N_o$)
F_k	Represent the interference-channel gains from the k^{th} relay in BC-phase to primary user on subcarrier q , when the relays broadcast the signal to SU_s .

3.2.2 Rate Analysis for the Secondary Network of System Model 1

To analyze the rate of secondary network with the two-way AF relay in two phases to exchange the signals between the SUs, the transmission through relays is divided into two phases to complete the total transmission [26]. The SUs transmit simultaneously to the selected relay in multi access (MA) phase on subcarrier i , then the selected relay amplifies the received signal with amplification factor (A_f) and broadcasts it to SUs in broadcast phase (BC) on subcarrier j .

1. Multi Access (MA) phase: in this phase SUs are transmit the signals at the same time to the selected relay R_k in the allocated subcarrier i , the received signal in the k^{th} relay is:

$$y_i^k = \sqrt{p_{1i}^k} h_{1r_k} x_{1i}^k + \sqrt{p_{2i}^k} h_{2r_k} x_{2i}^k + \theta_i^k \quad (3.1)$$

Where θ_i^k is an additive white gaussian noise (AWGN) for RF channel, its substitution by symbol (σ^2).

2. Broad Cast (BC) phase: the selected relay then amplifies the received signal with amplification factor Af_j^k and forwards this signal on the subcarrier j . Assume $E[|x_{1i}|^2] = 1$, $E[|x_{2i}|^2] = 1$ where $E[.]$ is denoted by expectation factor [7]. The amplification factor is calculated from [10]:

$$Af_j^k = 1 / \sqrt{p_{1i}^k h_{1r_k}^2 + p_{2i}^k h_{2r_k}^2 + \sigma^2} \quad (3.2)$$

The delivered signal to SU_1 and SU_2 denoted in (3.3) and (3.5).

$$y_{1j} = Af \sqrt{p_{kj}} h_{r_{1k}} y_i^k + \sigma^2 \quad (3.3)$$

$$y_{1j} = \underbrace{Af \sqrt{p_{kj}} hr_{1k} \sqrt{p_{1i}} h_{1r_k} x_{1i}}_{\text{Inter-user Interference}} + \underbrace{Af \sqrt{p_{kj}} hr_{1k} \sqrt{p_{2i}} h_{2r_k} x_{2i}}_{\text{Signal}} + \underbrace{Af \sqrt{p_{kj}} hr_{1k} \sigma^2 + \sigma^2}_{\text{Noise}} \quad (3.4)$$

$$y_{2j} = Af \sqrt{p_{kj}} hr_{2k} y_i^k + \sigma^2 \quad (3.5)$$

$$y_{2j} = \underbrace{Af \sqrt{p_{kj}} hr_{2k} \sqrt{p_{1i}} h_{1r_k} x_{1i}}_{\text{Signal}} + \underbrace{Af \sqrt{p_{kj}} hr_{2k} \sqrt{p_{2i}} h_{2r_k} x_{2i}}_{\text{Inter-user Interference}} + \underbrace{Af \sqrt{p_{kj}} hr_{2k} \sigma^2 + \sigma^2}_{\text{Noise}} \quad (3.6)$$

$$SNR1 = \frac{|Af|^2 p_{kj} |hr_{1k}|^2 p_{2i} |h_{2r_k}|^2}{|Af|^2 p_{kj} |hr_{1k}|^2 \sigma^2 + \sigma^2} \quad (3.7)$$

$$SNR2 = \frac{|Af|^2 p_{kj} |hr_{2k}|^2 p_{2i} |h_{2r_k}|^2}{|Af|^2 p_{kj} |hr_{2k}|^2 \sigma^2 + \sigma^2} \quad (3.8)$$

Notice that this system is considered with a perfect sensing, there by the channel estimation can cancel the effectiveness of the inter-user-interference in (3.4) and (3.6) [7].

By substituting the amplification factor Af (3.2) into (3.7) and (3.8), Numerator and denominator are divided by σ^4 and is given by:

$$SNR1 = \frac{P_{kj} HR_{1k} P_{2i} H_2 R_k}{P_{kj} HR_{1k} + p_{1i} H_1 R_k + p_{2i} H_2 R_k + 1} \quad (3.9)$$

$$SNR2 = \frac{P_{kj} HR_{2k} P_{1i} H_1 R_k}{P_{kj} HR_{2k} + p_{1i} H_1 R_k + p_{2i} H_2 R_k + 1} \quad (3.10)$$

Where: $HR_{sk} = \frac{|hr_{sk}|^2}{\sigma^2}$, $H_s R_k = \frac{|h_s r_k|^2}{\sigma^2}$.

The total transmission rate of SU_1 and SU_2 with the assistance of two-way AF relays on sub-carrier $\langle i, j \rangle$ with two time slots is given by [27]:

$$R_{AF}^{i,j,k} = \frac{1}{2} \log_2 (1 + SNR1) + \frac{1}{2} \log_2 (1 + SNR2) \quad (3.11)$$

Where: $SNR1$, $SNR2$ represent the signal to noise ratio of SU_1 and SU_2 , respectively.

3.2.3 Interference Analysis for Secondary Network for System Model 1

To analyze the interference for secondary network with perfect spectrum sensing, means that the SU_s detect the spectrum perfectly without harming the PU_d . The interference from SU_s on subcarrier- i to the PU_d on subcarrier- q is given by:

$$I_{Si} = \sum_{i \in N_v} \sum_{k \in \mathcal{K}} \left(p_{1i} \sum_{q \in N_o} |f_{1q}|^2 + p_{2i} \sum_{q \in N_o} |f_{2q}|^2 \right) \leq I_{th} \quad (3.12)$$

The interference from relay nodes on subcarrier- j to PU_d on subcarrier- q is:

$$I_{kj} = \sum_{j \in N_v} \sum_{k \in \mathcal{K}} \left(p_{kj} \sum_{q \in N_o} |f_{kq}|^2 \right) \leq I_{th} \quad (3.13)$$

3.2.4 Problem Formulation for System Model 1

The objective function for this model is to maximize the total system capacity that leads to maximize the total transmission rate according to *Shannon theory* [9], [13]. The RA and relay selection under the interference threshold and maximum transmission power for secondary network constraints are adopted in this system model. To explain this problems, a two-dimensions binary matrix denotes $(A_{i \times j})$ is considered, where the index $\langle i, j \rangle$ is refer to subcarrier pairing. However when A is equal to 1, this meaning the subcarrier i is allocated for SU_s in MA-phase and the subcarrier- j is allocated for k^{th} relay in BC-phase. In other words, when the element of A is equal to 1, the SU transmitter will

transmit the data to k^{th} relay node in the MA-phase, and the k^{th} relay node will AF the signal to the receiver SU in the BC-phase mode. In addition, a three-dimensional binary matrix denotes as $(B_{i \times j \times k})$ is considered, where the index $(i \times j \times k)$ is referred to the subcarrier pair $\langle i, j \rangle$ based on the k^{th} relay. In other words, where the element in B is equal to 1, that means the subcarrier pair $\langle i, j \rangle$ is allocated to the k^{th} relay.

The constraints for the optimization problems to maximize the total transmission-rate for secondary network include: c1 if the *subcarrier* i is paired with subcarrier- j , c2 the subcarrier pair $\langle i, j \rangle$ is allocated to the k^{th} relay, c3 and c4 for the transmission-power from the SU_s and k^{th} relay must be less than the maximum power, respectively, the c5 and c6 refer to the interference power from SU_s and from k^{th} relay which must be less than the interference threshold that is known by the PU_s , respectively. [8], [10].

$$OP: \left(\begin{matrix} \max \\ A, B, P \end{matrix} \right) \sum_{i \in N_v} \sum_{j \in N_v} \sum_{k \in \mathcal{K}} B_{i,j,k}^k A_{i,j} R_{AF}^{i,j,k} \quad (3.14)$$

$$c1: \sum_{i \in N_v} A = 1, \quad \sum_{j \in N_v} A = 1 \quad (3.14a)$$

$$c2: \sum_{k \in \mathcal{K}} B = 1, \quad \text{for all } \langle i, j \rangle \quad (3.14b)$$

$$c3: \sum_{i \in N_v} \sum_{k \in \mathcal{K}} p_{si} \leq p_{S \max}. \quad \text{for } s = 1, 2 \quad (3.14c)$$

$$c4: \sum_{j \in N_v} p_{kj} \leq p_{k \max}. \quad \text{for all } k \quad (3.14d)$$

$$c5: I_{Si} = \sum_{i \in N_s} \sum_{k \in \mathcal{K}} \left(p_{1i} \sum_{q \in N_o} |f_{1q}|^2 + p_{2i} \sum_{q \in N_o} |f_{2q}|^2 \right) \leq I_{th} \quad (3.14e)$$

$$c6: I_{kj} = \sum_{j \in N_v} \sum_{k \in \mathcal{K}} \left(p_{kj} \sum_{q \in N_o} |f_{kq}|^2 \right) \leq I_{th} \quad (3.14f)$$

3.3 System Model 2 OFDM Based-Cognitive (One-Way AF) Relay Network

In this model, OFDM system is based on cognitive with half-duplex dual-hop (one-way with two phases) AF relay network with a perfect spectrum sensing. The power allocation, subcarrier allocation, and relay selection, which are under the interference threshold and power constraints to prevent the secondary network from harmful the primary users are considered.

3.3.1 System Model

This model is considered a part from system model1. All definitions are mentioned in section 3.2. One primary user pair PU_s and PU_d shares the licensed band with the other one pair of SU_s and SU_d . Some relay nodes are used to assist the secondary users through allowing the SU_s to communicate with SU_d in lower transmission power and for farther distant. The total frequency band owned by the licensed user is divided into some subcarrier equal to N subcarrier, all symbols used in this model are defined in system model1. To implement the system model 2, the numbers for all variables of this system are illustrated in Table 3.1, and the system definitions are in Table 3.3. The system model is depicted in Fig. 3.2.

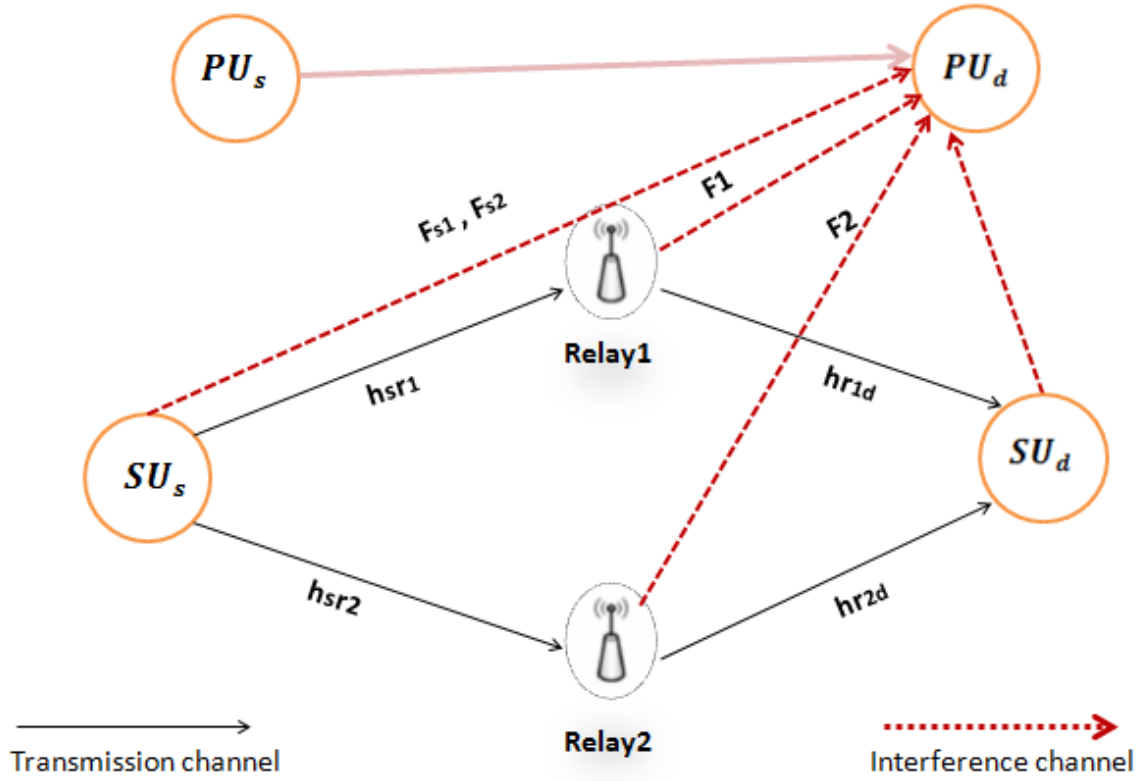

Fig. 3.2: System Model 2

Table-3.3: System Definitions for System Model

i	Subcarrier for phaseI from SU_s to Relay nodes. $i \in N_v$
j	Subcarrier for phaseII from relays to SU_d . $j \in N_v$
x_{si}	Describe the transmitted symbols from SU_s on subcarrier i
p_{si}	Power allocation to SU_s when sending to k^{th} relay on phaseI
$h_s r_k$	Represent the channel-gains when SU_s sending to k^{th} relay on phaseI
hr_{kd}	Represent the channel-gains from k^{th} relay to SU_d on phaseII
p_{kj}	Power allocation to k -relay when sending to SU_d on phaseII
F_{sp}	Represent the interference-channel gains from SU_s on phaseI to primary user on subcarrier q , when SU_s transmits to k^{th} relay.
F_k	Represent the interference-channel gains from the k^{th} relay on phaseII to primary user on subcarrier q , when the relays forward the signal to SU_d .

3.3.2 Rate Analysis for Secondary Network for System Model 2

To analyze the transmission rate of secondary network with one-way AF relay, the transmission signal from the SU_s to SU_d will take two phases. In the first phase SU_s transmits the signal to the selected relay on subcarrier i in phase I, then in the second phase the selected relay amplifies the received signal with amplification factor (A_f) and forwards it to SU_d in phase II on subcarrier j [26].

1. phase I: the SU_s transmits the signals to the selected relay R_k in the allocated subcarrier i , so the received signal at the k^{th} relay is given by:

$$y_i^k = \sqrt{p_{1i}^k} h_{sr_k} x_{1i}^k + \theta_i^k \quad (3.15)$$

The Signal to Noise ratio at relay nodes is:

$$SNR_{sR} = \frac{p_{1i}^k |h_{sr_k}|^2}{\sigma^2} \quad (3.16)$$

2. phase II: the selected relay then amplifies the received signal with amplification factor Af_j^k and forwards this signal on the subcarrier- j . Assume the expectation operator of $E(|x_{1i}|^2) = 1$, $E(|x_{2i}|^2) = 1$ denoted by $E(\cdot)$ [7].

$$Af_j^k = 1/\sqrt{y_i^{k2} + \sigma^2} = 1/\sqrt{p_{1i}^k |h_{sr_k}|^2 + \sigma^2} \quad (3.17)$$

Where σ^2 is the AWGN from k^{th} relay into SU_d . The received signal at the SU_d is given by:

$$y_j = Af \sqrt{p_{kj}} h_{rkd} y_i^k + \sigma^2 \quad (3.18)$$

$$y_j = Af \sqrt{p_{kj}} h_{rkd} \sqrt{p_{si}} h_{sr_k} x_{si} + Af \sqrt{p_{kj}} h_{rkd} \sigma^2 + \sigma^2 \quad (3.19)$$

The signal to noise ratio at SU_d is given by:

$$SNR_{Rd} = \frac{|Af|^2 p_{kj} |hr_{kd}|^2 p_{si} |h_{sr_k}|^2}{|Af|^2 p_{kj} |hr_{kd}|^2 \sigma^2 + \sigma^2} \quad (3.20)$$

By substituting of the amplification factor Af (3.17) into (3.20), and Numerator and denominator are divided by σ^4 , we will get:

$$SNR_{Rd} = \frac{P_{kj} HR_{kd} P_{si} H_S R_k}{P_{kj} HR_{kd} + p_{si} H_S R_k + 1} \quad (3.21)$$

$$\text{Where: } HR_{kd} = \frac{|hr_{kd}|^2}{\sigma^2}, \quad H_S R_k = \frac{|h_{sr_k}|^2}{\sigma^2}.$$

The total transmission rate of SU_s with the assistance of one-way AF relays on sub-carrier $\langle i, j \rangle$ with two time slots SU_d is [27] given by:

$$R_{AF}^{i,j,k} = \frac{1}{2} \log_2 (1 + SNR_{sR}) + \frac{1}{2} \log_2 (1 + SNR_{Rd}) \quad (3.22)$$

Where: $SNR1$, $SNR2$ represent the signal to noise ratio of SU_1 and SU_2 , respectively.

3.3.3 Interference Analysis for Secondary Network for System Model 2

To analyze the interference for secondary network with perfect spectrum sensing, means that the SU_s detect the spectrum perfectly without harming the PU_d . The interference from SU_s subcarrier i to the PU_d on subcarrier- q is:

$$I_{Si} = \sum_{i \in N_v} \sum_{k \in \mathcal{K}} \left(p_{si} \sum_{q \in N_o} |f_{sq}|^2 \right) \leq I_{th} \quad (3.23)$$

The interference from relay nodes subcarrier- j to PU_d on subcarrier- o is:

$$I_{kj} = \sum_{j \in N_v} \sum_{k \in \mathcal{K}} \left(p_{kj} \sum_{q \in N_o} |f_{kq}|^2 \right) \leq I_{th} \quad (3.24)$$

3.3.4 Problem Formulation for System Model 2

The objective function for this model is to maximize the total system capacity that leads to maximize of the total transmission rate according to *Shannon theory* [9], [13]. RA and relay selection under the interference threshold and maximum transmission power for secondary network constraints are adopted in this system model. To illustrate the problem, a two-dimensions binary matrix denotes $(A_{i \times j})$ considered, where the index $\langle i, j \rangle$ is refer to subcarrier pairing. However, if A equals to 1, meaning that the subcarrier i is allocated for SU_s is assigned to phaseI (when the SU_s transmit to k^{th} relay), and the subcarrier- j allocated to k^{th} relay is assigned to phaseII (when the k^{th} relay amplifies the received signal and forward it to SU_d). In addition, three-dimension binary matrix denotes $(B_{i \times j \times k})$ is considered, if B equal to 1 That means the subcarrier pair $\langle i, j \rangle$ is allocated to the k^{th} relay.

The constraints for the optimization problems to maximization the total transmission-rate for secondary network include: c1 if the subcarrier i is paired with subcarrier- j , c2 the subcarrier pair $\langle i, j \rangle$ is allocated to the k^{th} relay, c3and c4 for transmission-power from SU_s and from k relay must be less than the maximum power, respectively, the c5 and c6 refer to the interference power from SU_s and from k^{th} relay which must be less than the interference threshold that is known by the PU_s , respectively. [8], [10].

$$OP: \left(\begin{matrix} max \\ A, B, P \end{matrix} \right) \sum_{i \in N_v} \sum_{j \in N_v} \sum_{k \in \mathcal{K}} B_{i,j}^k A_{i,j} R_{AF}^{i,j,k} \quad (3.25)$$

$$c1: \sum_{i \in N_v} A = 1, \sum_{j \in N_v} A = 1 \quad (3.25a)$$

$$c2: \sum_{k \in \mathcal{K}} B = 1, \text{ for all } \langle i, j \rangle \quad (3.25b)$$

$$c3: \sum_{i \in N_v} \sum_{k \in \mathcal{K}} p_{si} \leq p_{S \max}. \text{ for } s = 1, 2 \quad (3.25c)$$

$$c4: \sum_{j \in N_v} p_{kj} \leq p_{k \max}. \text{ for all } k \quad (3.25d)$$

$$c5: I_{Si} = \sum_{i \in N_s} \sum_{k \in \mathcal{K}} \left(p_{1i} \sum_{q \in N_o} |f_{sq}|^2 \right) \leq I_{th} \quad (3.25e)$$

$$c6: I_{kj} = \sum_{j \in N_v} \sum_{k \in \mathcal{K}} \left(p_{kj} \sum_{q \in N_o} |f_{kq}|^2 \right) \leq I_{th} \quad (3.25f)$$

3.4 System Model 3 Interference Managements for OFDM-Based Small Cells Cognitive Relay Heterogeneous Networks

In this model, the power allocation and subcarrier allocation are adopted for the cognitive-based small cells and for Amplify and Forward (AF) relay nodes with two-way protocol, under the maximum transmission power constraint for the small cell users SUs and the interference power (caused by secondary network to primary users) constraint. The cross-tier interference which caused by MBS affect on secondary network is simultaneously considered. The objective function here is to maximize the total transmission-rate between the small cell users (SUs) with assistance AF relay nodes.

3.4.1 System Model

In this model, a multiple small cells are deployment, where cognitive heterogeneous network (HetNet) is considered and consist of one macro cell, multiple-small cells and multiple-relay nodes. Macro cell is defined as (primary network) and small cells with relay nodes are defined as (secondary networks).

The set of relay nodes is defined as $\mathcal{K}=\{1,\dots, k,\dots,K\}$ and the set of small cell users is defined as $\mathcal{S} = \{SU_1, SU_2, \dots, SU_n\}$ with the notice that (n: represents total number of small cells). The total licensed frequency band used by primary network (macro cell) can be divided into smaller parts or a specific numbers of sub-carriers that are equal to N subcarriers, the set of subcarriers denoted as $\mathcal{N}=\{1,2,\dots,n,\dots,N\}$. The set of subcarriers occupied by primary network and defined as $N_p= \{1,\dots, l,\dots, L\}$, small cell users perfectly sensing the spectrum band and detecting the unused subcarriers, and with underlay spectrum access way. The small cell users and relay nodes are accessing the spectrum and allocating the vacant subcarriers defined as $N_s= \{1,\dots, m,\dots, M\}$. OFDM technique is adopted for the transmission mechanism for the macro cell, small cells and relay nodes. Figure 3.3 shows in general the overall proposed system model.

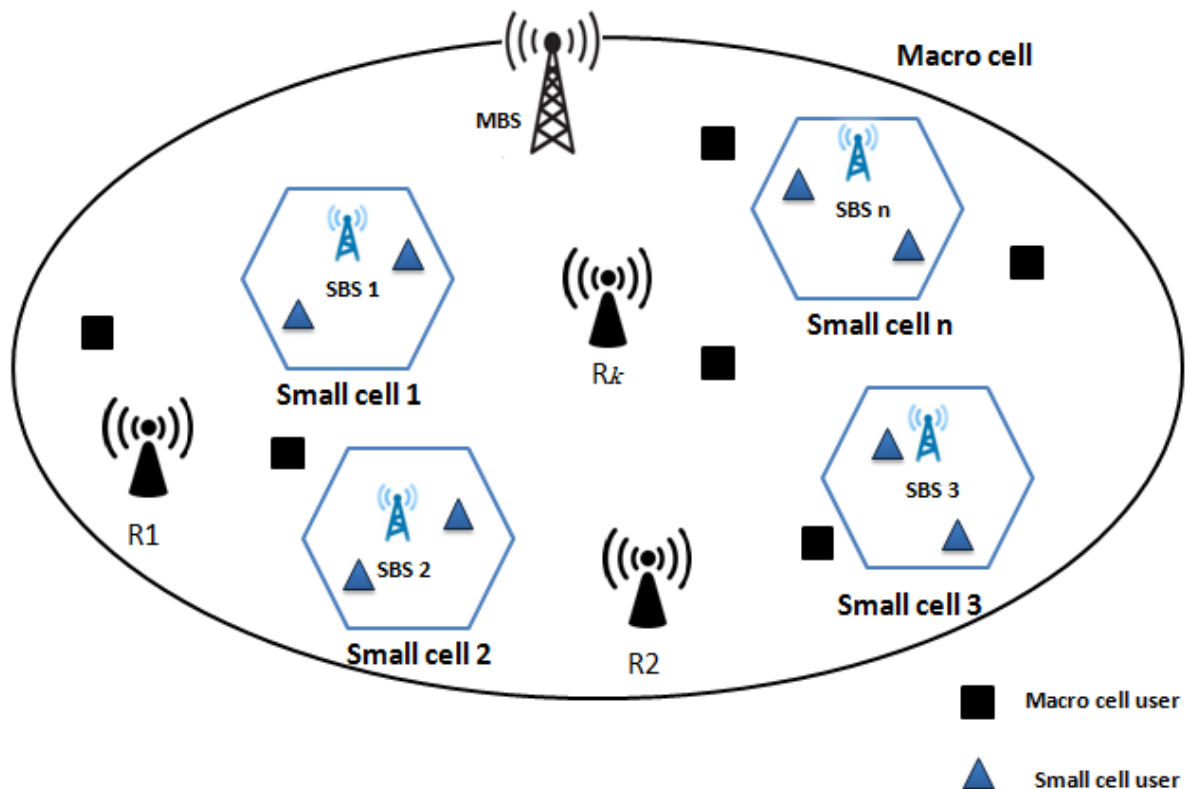

Fig. 3.3: General model for system model 3

The implemented system shown in Fig. 3.4, consist of one macro cell (primary network) with one macro cell base station (MBS) and one macro cell user pair (sender MU-s and destination MU-d). It also consist of two small cells base station (SBS1) and (SBS2). Each small cell has one small cell user, SU1 and SU2, to communicate with each other through two relay nodes R1 and R2 in two-way protocol and half duplex mode to exchange the messages between the SUs. The total spectrum band is divided into 6 subcarriers $N = \{1, 2, 3, 4, 5, 6\}$; two subcarriers are occupied by macro cell users $N_p = \{1, 2\}$, and the other unused subcarriers are used by secondary network $N_s = \{3, 4, 5, 6\}$, (where these numbers represent the indicator of subcarriers). All system definitions are listed in the Table 3.4.

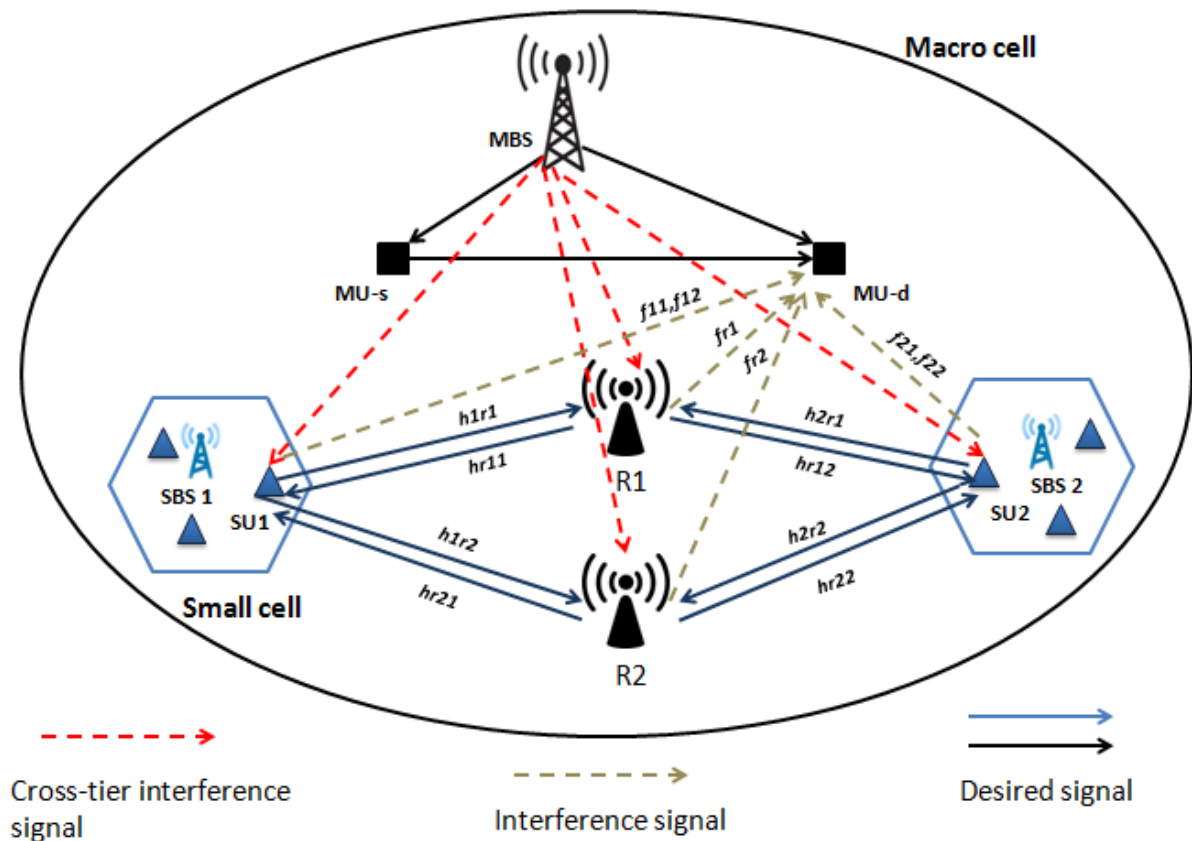

Fig. 3.4: Implemented model for system model 3

Table-3.4: System Definitions for System Model 3

\mathcal{K}	Identify the number of relay nodes $\{1, \dots, k, \dots, K\}$
N	Total Bandwidth divided into N subcarrier
N_p	no. of subcarrier used by macro cell (primary) user $N_p \in \mathcal{N}$ $N_p = \{1, \dots, l, \dots, L\}$
N_s	no. of subcarrier used by small cell (secondary) network $N_s \in \mathcal{N}$ $N_s = \{1, \dots, m, \dots, M\}$
i	subcarrier for MA phase from (SUs) to Relays, $i \in N_s$
j	subcarrier for BC phase from relays to (SUs) , $j \in N_s$
x_{si}	Represent the symbols transmitted by SUs on sub-carrier i
p_{si}	Power allocation to small cell users when sending to k^{th} relay in MA phase.
h_{nr_k}	Represent the channel-gains when small cell users sending to k^{th} relay in MA phase
hr_{kn}	Represent the channel-gains from k -relay to small cell users in BC phase
p_{rj}	Power allocation to k^{th} relay when sending to small cell user in BC phase
f_{il}	Represent the interference-channel gains from small cell users in MA phase to macro cell users on sub-carrier l , when SUs transmits to relays
fr_l	Represent the interference-channel gains from the k^{th} relay in BC phase to macro cell user on sub-carrier l , when the relays broadcast the signal to SUs
hc_{ki}	Cross-tier interference channel effect on k^{th} relay when it received a signals from SUs in MA on subcarrier i
hc_{nj}	Cross-tier interference channel effect on SUs when received a signals from k^{th} relay in BC on subcarrier j
p_{MBS}	Transmit power from macro cell base station.

3.4.2 Rate Analysis for Secondary Network for System Model 3

To analyze the rate of secondary networks with the AF two-way relays, it takes two phases to exchange the signals between the SUs. The transmission through relays is divided into two phases to complete the total transmission: the SUs transmit simultaneously to the selected relay in MA phase on subcarrier i , then the selected relay amplifies the received signal with amplification factor (A_f) and broadcasts it to SUs in broadcast phase (BC) on subcarrier j [26].

1. Multi Access (MA) phase: the SUs users transmit signals in the same time to the k -relay on the allocated sub-carrier (i). The signal received at the k^{th} relay is:

$$y_i^k = \sqrt{p_{1i}} h_{1r_k} x_{1i} + \sqrt{p_{2i}} h_{2r_k} x_{2i} + \theta_i^k + Z_i^k \quad (3.26)$$

Where θ_i^k is a thermal noise power of AWGN at the relay k which caused by SUs on sub-carrier i , and it is same in all receivers (assuming the mean equals to zero $\mu=0$ and the variance $\sigma^2=0.01$) which are defined as (μ, σ^2) , then $\theta_i^k = \sigma^2$. And Z_i^k Cross-tier interference from MBS with each signal transmits from SUs to k^{th} relay in MA on subcarrier i , assuming the total noise power from SUs to relay nodes is denoted by a symbol nr_i^k , and calculated in eq.(3.27) is given by.

$$nr_i^k = \sigma^2 + Z_i^k \quad (3.27)$$

2. Broad Cast (BC) phase: the k^{th} relay then amplifies the received signal with amplification factor A_f and forwards this signal on the subcarrier j , assuming the expectation operator of $E[|x_{1i}|^2] = 1$, $E[|x_{2i}|^2] = 1$ is denoted by $E[.]$ [7].

$$A_f = \frac{1}{\sqrt{p_{1i} |h_{1r_k}|^2 + p_{2i} |h_{2r_k}|^2 + (nr_i^k)^2}} \quad (3.28)$$

The received signal at SU1, SU2 from k^{th} relay (broadcast signal) on subcarrier j denoted: y_{1j} , y_{2j} , respectively.

$$y_{1j} = A_f \sqrt{p_{rj}} h_{r1k} y_i^k + \theta_j^k + Z_j^k \quad (3.29)$$

$$y_{1j} = \underbrace{A_f \sqrt{p_{rj}} h_{r1k} \sqrt{p_{1i}} h_{1r_k} x_{1i}}_{\text{Inter-user Interference}} + \underbrace{A_f \sqrt{p_{rj}} h_{r1k} \sqrt{p_{2i}} h_{2r_k} x_{2i}}_{\text{Signal}} + \underbrace{A_f \sqrt{p_{rj}} h_{r1k} nr_i^k + n_{1j}^k}_{\text{Noise}} \quad (3.30)$$

$$y_{2j} = A_f \sqrt{p_{rj}} h r_{2k} y_i^k + \theta_j^k + \mathcal{Z}_{2j}^k \quad (3.31)$$

$$y_{2j} = \underbrace{A_f \sqrt{p_{rj}} h r_{2k} \sqrt{p_{1i}} h_1 r_k x_{1i}}_{\text{Signal}} + \underbrace{A_f \sqrt{p_{rj}} h r_{2k} \sqrt{p_{2i}} h_2 r_k x_{2i}}_{\text{Inter-user Interference}} + \underbrace{A_f \sqrt{p_{rj}} h r_{2k} n r_i^k + n_{2j}^k}_{\text{Noise}} \quad (3.32)$$

Where, \mathcal{Z}_{1j}^k and \mathcal{Z}_{2j}^k are the cross-tier noises from MBS with each signal broadcasted from k^{th} relay to SU1, SU2, respectively in BC phase on subcarrier j , on the assumption that the total noise signal at SU1 is denoted by n_{1j}^k and SU2 denoted by n_{2j}^k , and can be calculated in (3.33) and (3.34), respectively:

$$n_{1j}^k = \sigma^2 + \mathcal{Z}_{1j}^k \quad (3.33)$$

$$n_{2j}^k = \sigma^2 + \mathcal{Z}_{2j}^k \quad (3.34)$$

With perfect channel state information that leads to the inter-user interference part in (3.30) and (3.32) which can be eliminated using channel estimation [7], [10], then the SINR (the signal to cross-tier interference plus noise ratio) can be calculated as:

$$SINR_1 = \frac{A_f^2 p_{rj} |h r_{1k}|^2 p_{2i} |h_2 r_k|^2}{A_f^2 p_{rj} |h r_{1k}|^2 n r_i^{k^2} + n_{1j}^{k^2}} \quad (3.35)$$

$$SINR_2 = \frac{A_f^2 p_{rj} |h r_{2k}|^2 p_{1i} |h_1 r_k|^2}{A_f^2 p_{rj} |h r_{2k}|^2 n r_i^{k^2} + n_{2j}^{k^2}} \quad (3.36)$$

By dividing (3.35) by $(A_f^2 n r_i^{k^2} n_{1j}^{k^2})$, (3.36) by $(A_f^2 n r_i^{k^2} n_{2j}^{k^2})$, and substituting this equation:

$$\frac{1}{A_f^2} = p_{1i} |h_1 r_k|^2 + p_{2i} |h_2 r_k|^2 + (n r_i^k)^2, \text{ the result equal to:}$$

$$\begin{aligned}
SINR_1 &= \frac{\frac{A_f^2}{A_f^2} p_{rj} \frac{|hr_{1k}|^2}{n_{1j}^{k^2}} p_{2i} \frac{|h_2 r_k|^2}{nr_i^{k^2}}}{\frac{A_f^2}{A_f^2} p_{rj} \frac{|hr_{1k}|^2}{n_{1j}^{k^2}} \frac{nr_i^{k^2}}{nr_i^{k^2}} + \frac{n_{1j}^{k^2}}{A_f^2 n_{1j}^{k^2} nr_i^{k^2}}} \\
&= \frac{P_{rj} HR_{1k} P_{2i} H_2 R_k}{P_{rj} HR_{1k} + \frac{p_{1i} |h_1 r_k|^2 + p_{2i} |h_2 r_k|^2 + (nr_i^k)^2}{nr_i^{k^2}}}
\end{aligned}$$

Then,

$$SINR_1 = \frac{P_{rj} HR_{1k} P_{2i} H_2 R_k}{P_{rj} HR_{1k} + p_{1i} H_1 R_k + p_{2i} H_2 R_k + 1} \quad (3.37)$$

$$\begin{aligned}
SINR_2 &= \frac{\frac{A_f^2}{A_f^2} p_{rj} \frac{|hr_{2k}|^2}{n_{2j}^{k^2}} p_{1i} \frac{|h_1 r_k|^2}{nr_i^{k^2}}}{\frac{A_f^2}{A_f^2} p_{rj} \frac{|hr_{2k}|^2}{n_{2j}^{k^2}} \frac{nr_i^{k^2}}{nr_i^{k^2}} + \frac{n_{2j}^{k^2}}{A_f^2 n_{2j}^{k^2} nr_i^{k^2}}} \\
&= \frac{P_{rj} HR_{2k} P_{1i} H_1 R_k}{P_{rj} HR_{2k} + \frac{p_{1i} |h_1 r_k|^2 + p_{2i} |h_2 r_k|^2 + (nr_i^k)^2}{nr_i^{k^2}}}
\end{aligned}$$

And,

$$SINR_2 = \frac{P_{rj} HR_{2k} P_{1i} H_1 R_k}{P_{rj} HR_{2k} + p_{1i} H_1 R_k + p_{2i} H_2 R_k + 1} \quad (3.38)$$

Where, $H_n R_k = \frac{|h_n r_k|^2}{nr_i^{k^2}}$, $HR_{1k} = \frac{|hr_{nk}|^2}{n_{1j}^{k^2}}$

Where, $SINR_1$, $SINR_2$ are signals to noise plus cross-tier interference ratio calculated at SU_1 , SU_2 , respectively after the signal is amplified and broadcasted from k relay on subcarrier j .

The total transmission rate of SUs with the assistance of AF with two-way protocol of k^{th} relay on subcarrier pairs $\langle i, j \rangle$ can be calculated with two time slots to complete the transmission messages between SU_s : [15]-[18].

$$R_{AF}^{i,j,k} = \frac{1}{2} (\log_2(1 + SINR_1) + \log_2(1 + SINR_2)) \quad (3.39)$$

3.4.3 Interference Analysis for Secondary Network for System Model 3

To analyze the interference from secondary network (SUs with relay nodes) to primary network with a perfect sensing of licensed spectrum, means that the SUs detect only the unused subcarrier perfectly, leading to SUs use subcarriers that are different from primary users. The interference power from secondary users on subcarriers i , when sending to all k^{th} relay nodes in MA phase denote as I_{si} , and the interference power from k^{th} relay on subcarrier j , when they amplify and broadcast to SUs in BC phase denote as I_{rj} , and must be less than I_{th} threshold interference defined by Primary network.

$$I_{si} = \sum_{i \in N_s} \sum_{k \in \mathcal{K}} \left(p_{1i} \sum_{l \in N_p} |f_{1l}|^2 + p_{2i} \sum_{l \in N_p} |f_{2l}|^2 \right) \leq I_{th} \quad (3.40)$$

$$I_{rj} = \sum_{j \in N_s} \sum_{k \in \mathcal{K}} \left(p_{rj} \sum_{l \in N_p} |f_{rl}|^2 \right) \leq I_{th} \quad (3.41)$$

To analyze the cross-tier interference from MBS to secondary network, the cross-tier interference power affect on k^{th} relay when it receives a signals from SUs in MA on sub-carrier i is \mathcal{Z}_i^k calculated in (3.42). The cross-tier interference power affect on SUs receiving signals from k relay in BC on sub-carrier j is \mathcal{Z}_{1j}^k and \mathcal{Z}_{2j}^k calculated in (3.43).

$$\mathcal{Z}_i^k = \sum_{l \in N_p} \left(\sum_{k \in \mathcal{K}} p_{MBS} \sum_{i \in N_s} |hc_{ki}|^2 \right) \quad (3.42)$$

$$Z_{sj}^k = \sum_{i \in N_p} \sum_{k \in \mathcal{K}} \left(p_{MBS} \sum_{j \in N_s} |hc_{1j}|^2 + p_{MBS} \sum_{j \in N_s} |hc_{2j}|^2 \right) \quad (3.43)$$

3.4.4 Problem Formulation for System Model 3

The identification of the objective function in this model is to maximize the total data rate for secondary network, with the power constraints for secondary network and the interference constraints from secondary network to macro cell network. To solve this problem, a two dimension binary matrix $A_{i \times j}$ is considered. Where $A \in \{0,1\}$, if $A=1$, means that the subcarrier i is allocated to SUs when transmit to k^{th} relay on MA phase. And the subcarrier j is allocated to k^{th} relay when AF the signal and transmit to SUs on BC phase. Then the subcarrier i is paired with subcarrier j denoted by a symbol $\langle i, j \rangle$. In addition, a three dimension matrix $B_{i \times j \times k}$ is considered, where $B \in \{0,1\}$ if $B=1$ means that the subcarrier pair $\langle i, j \rangle$ allocated for k^{th} relay. To solving this formulation problem to maximization the total transmission rate for some constraints. The Power constraint from SUs is c3 and for k^{th} relay is c4. The interference constraint from SUs is c5 and from k relay is c6 [8], [10].

$$OP: \left(\begin{matrix} \max \\ A, B, P \end{matrix} \right) \sum_{i \in N_s} \sum_{j \in N_s} \sum_{k \in \mathcal{K}} B_{i,j}^k A_{i,j} R_{AF}^{i,j,k} \quad (3.44)$$

$$c1: \sum_{i \in N_s} A = 1, \quad \sum_{j \in N_s} A = 1 \quad (3.44a)$$

$$c2: \sum_{k \in \mathcal{K}} B = 1, \quad \text{for all } \langle i, j \rangle \quad (3.44b)$$

$$c3: \sum_{i \in N_s} \sum_{k \in \mathcal{K}} p_{si} \leq p_{s \max} \quad \text{for } s = 1, 2 \quad (3.44c)$$

$$c4: \sum_{j \in N_s} p_{rj} \leq p_{r \max} \quad \text{for all } k \quad (3.44d)$$

$$c5: I_{si} = \sum_{i \in N_s} \sum_{k \in K} \left(p_{1i} \sum_{l \in N_p} |f_{1l}|^2 + p_{2i} \sum_{l \in N_p} |f_{2l}|^2 \right) \leq I_{th} \quad (3.44e)$$

$$c6: I_{rj} = \sum_{j \in N_s} \sum_{k \in K} \left(p_{rj} \sum_{l \in N_p} |f_{rl}|^2 \right) \leq I_{th} \quad (3.44f)$$

Chapter 4

Simulation Results and Discussion

4.1 System Model 1

The results will be viewed in detail for this system model with all calculations for optimization problems (subcarrier allocation, power allocation and relay selection).

4.1.1 Simulation Results for System Model 1

To maximize the total transmission-rate for secondary network and solve the optimization problems, GA is adopted in this thesis which obtains jointly the results of the resources allocation RA and relay selection. All parameters for GA and the power values used in this system model are listed in Table-4.1

Table-4.1: GA parameters and power values for System Model 1

number of iterations size data	10
number of initial generations data	100
total number of variables	$(X_T = 48)$
power variables	$(X_P = 24)$, its range 256 levels
subcarrier variables	$(X_F = 24)$, binary range (0 or 1)
Maximum transmission power for secondary users	$p_{Si} = 1.5 \text{ watt}$
Maximum transmission power for relay nodes	$p_{kj} = 1.5 \text{ watt}$
interference power threshold	$I_{th} = 1 \times 10^{-6} \text{ watt}$
AWGN	zero-mean and 0.01 variance

The adopted channel gains and interference-channel gains are independent-and-identically distributed (i.i.d) as $\mathcal{CN} \sim (\mu, \sigma^2)$ with zero mean [10].

The results of this system model are:

1. The subcarrier-pair matrix A and relay selection matrix B for each relay obtained from GA are:

$$A = \begin{bmatrix} 0 & 1 & 0 & 0 \\ 0 & 0 & 0 & 1 \\ 0 & 0 & 1 & 0 \\ 1 & 0 & 0 & 0 \end{bmatrix}$$

$$B_1 = \begin{bmatrix} 0 & 1 & 0 & 1 \\ 0 & 1 & 0 & 1 \\ 0 & 1 & 0 & 1 \\ 0 & 1 & 0 & 1 \end{bmatrix}, \quad B_2 = \begin{bmatrix} 1 & 0 & 1 & 0 \\ 1 & 0 & 1 & 0 \\ 1 & 0 & 1 & 0 \\ 1 & 0 & 1 & 0 \end{bmatrix}$$

$$A \times B_1 = \begin{bmatrix} 0 & 1 & 0 & 0 \\ 0 & 0 & 0 & 1 \\ 0 & 0 & 0 & 0 \\ 0 & 0 & 0 & 0 \end{bmatrix}, \quad A \times B_2 = \begin{bmatrix} 0 & 0 & 0 & 0 \\ 0 & 0 & 0 & 0 \\ 0 & 0 & 1 & 0 \\ 1 & 0 & 0 & 0 \end{bmatrix}$$

In matrix A : the rows represent the subcarriers- i while the columns represent the subcarriers- j . The values of ones in matrix A means that the subcarrier i of the MA-phase is paired with the subcarrier j of the BC-phase which known by subcarrier pairs $\langle i, j \rangle$. To distinguish if the subcarrier-pairs in matrix A is allocated to R_1 or R_2 , the matrix A will multiply (dot product) by each of the matrices B_1 and B_2 , respectively. According to that, the subcarrier-pair $\langle 1, 2 \rangle$ is allocated for R_1 , $\langle 2, 4 \rangle$ is allocated for R_1 , $\langle 3, 3 \rangle$ is allocated for R_2 and $\langle 4, 1 \rangle$ is allocated for R_2 . All of subcarrier-pairs which are allocated are shown in Fig. 4.1.

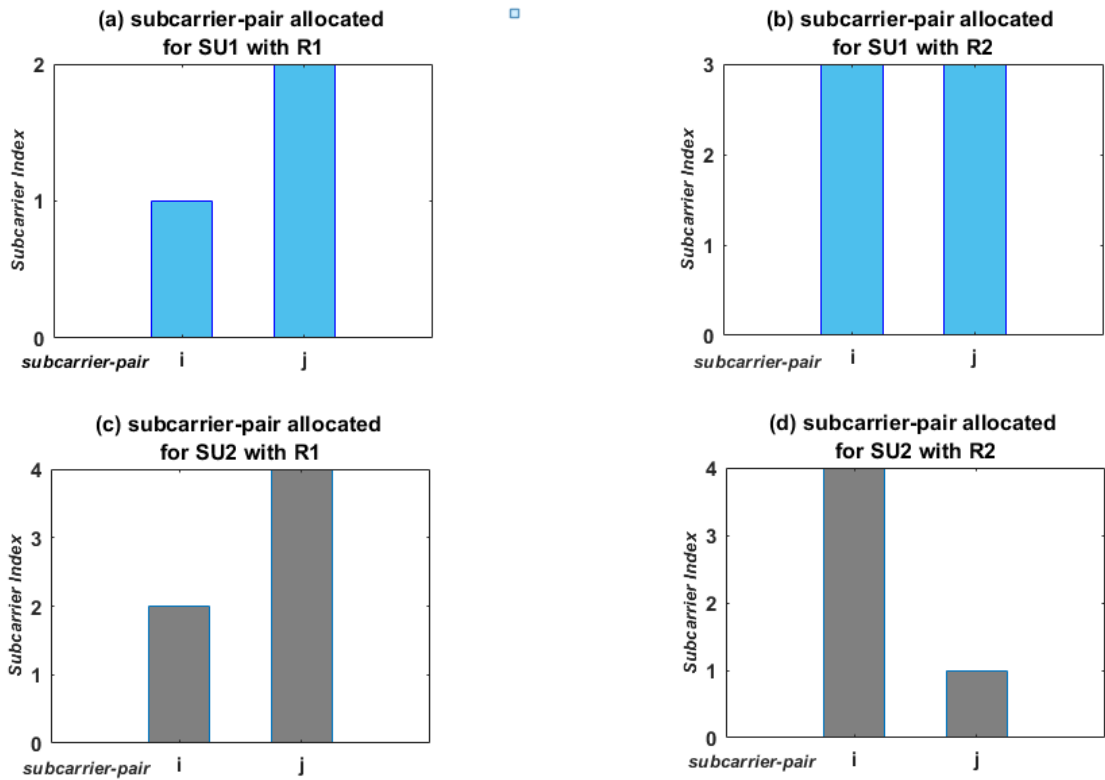

Fig. 4.1: Subcarrier-pairs allocated for all users with each relay nodes

2. The powers allocated for each of secondary users and relay nodes under maximum transmission-power constraint ($p_{Si} = 1.5 \text{ watt}$) are depicted in Fig. 4.2 and Fig. 4.3 respectively. The power values will be calculated for each subcarrier i when the SU_s transmitted to k^{th} relay, in addition it will be calculated for each subcarrier j when the k^{th} relay will AF the signal and transmitted to SU_s . Then, we will find the power allocated for each subcarrier pair $\langle i, j \rangle$ according to matrix A and the multiplication of $(A \times B_1 \text{ and } A \times B_2)$. The power values of each subcarrier pairs are listed in Table-4.2.

Table-4.2: allocated power values of subcarrier pairs for system model 1

R_1		R_2	
Subcarrier pairs	Power values	Subcarrier pairs	Power values
$\langle 1, 2 \rangle$	0.2477w, 0.414w	$\langle 3, 3 \rangle$	3e-07w, 0.3703w
$\langle 2, 4 \rangle$	0.2294w, 0.07262w	$\langle 4, 1 \rangle$	0.2049w, 0.229w

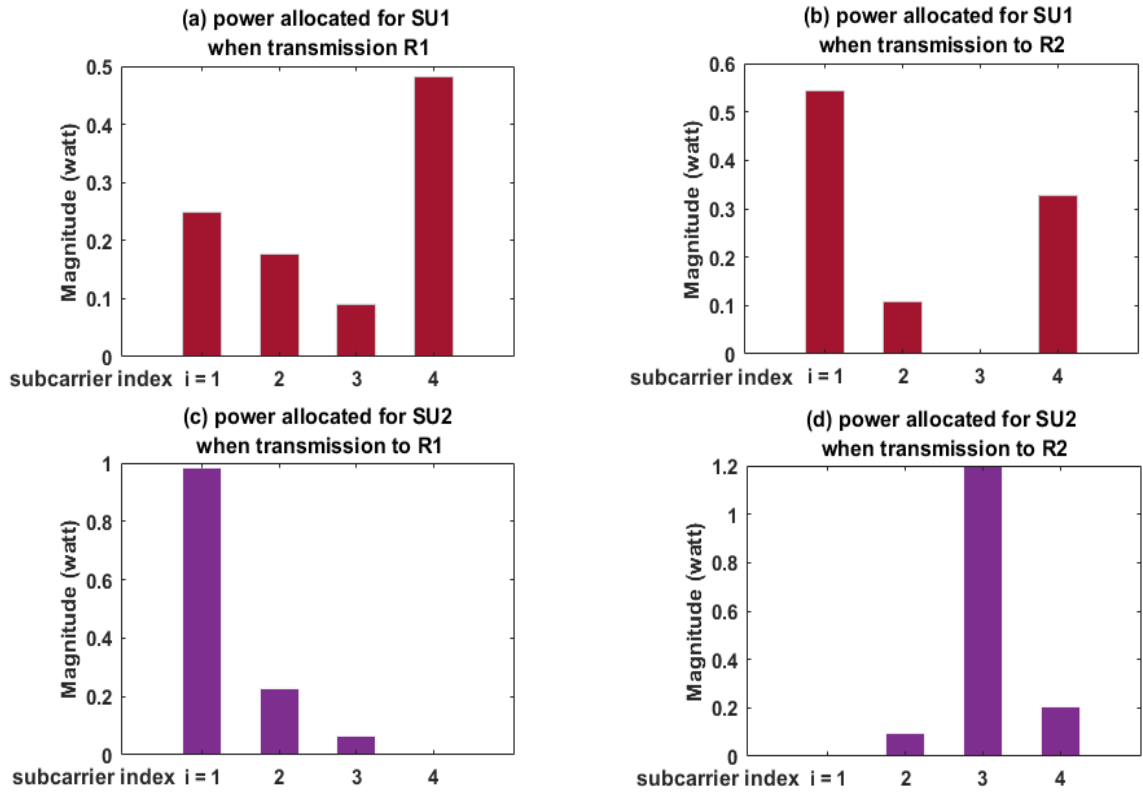

Fig. 4.2: Power allocated for secondary users when transmits to relay nodes on subcarrier- i for MA-phase

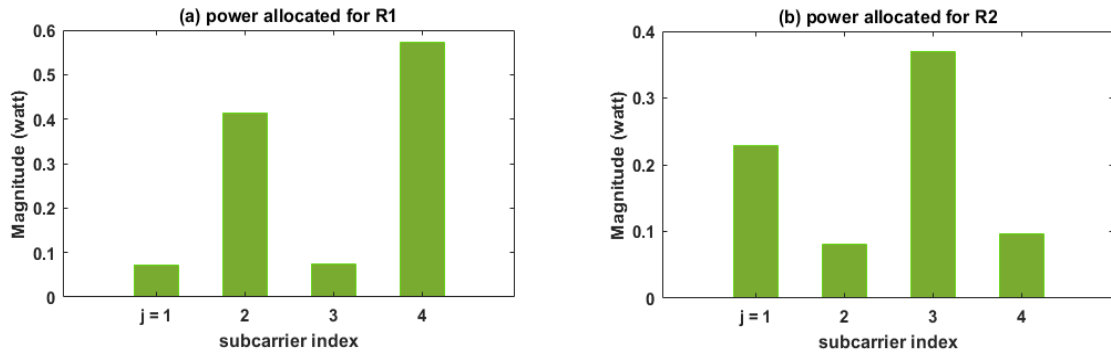

Fig. 4.3: Power allocated for relay nodes on subcarrier- j for BC-phase when it amplifies and forwards the signals to secondary users

3. The Signal to Noise ratio for SU_s with k^{th} relay shown in Fig. 4.4:

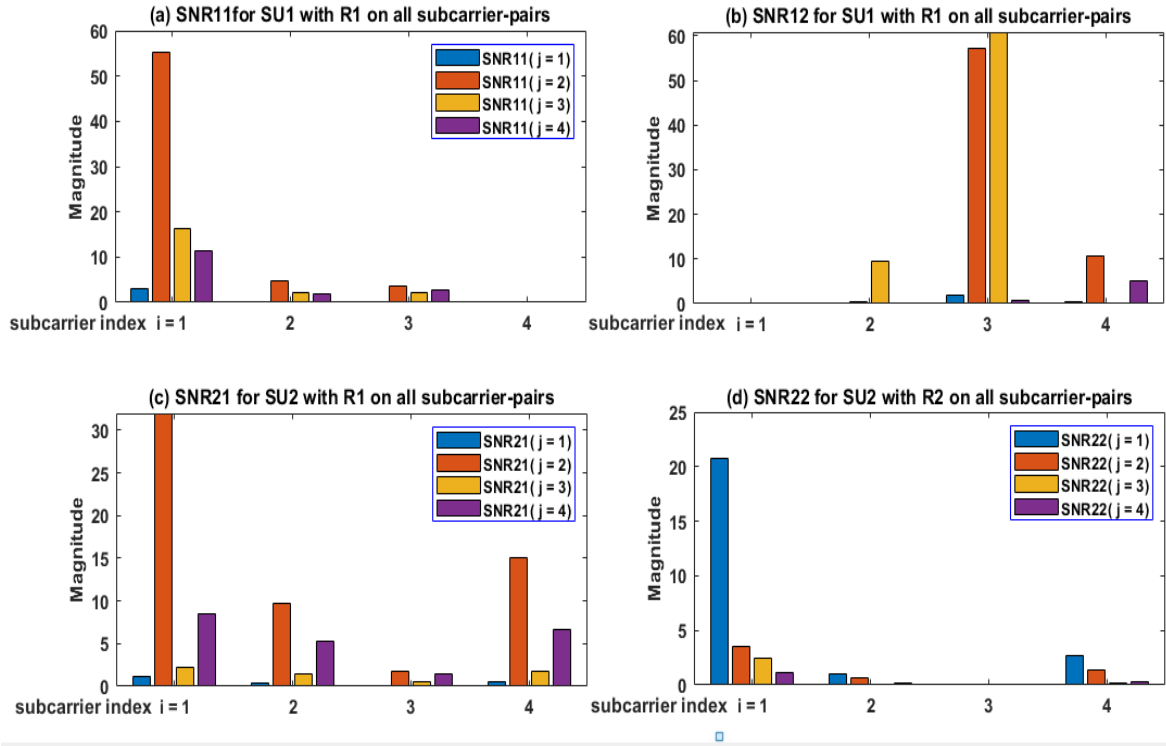

Fig. 4.4: SNR for all Subcarrier-pairs

Note that in Fig. 4.4 the value of SNR_{11} at the pair $\langle 1, 2 \rangle$ in Fig. 4.4(a) takes the highest value than the others SNR on the same pair. For this reason the subcarrier-pair depends on SNR when allocated to secondary users and relay nodes. Also for the same way in SNR_{12} in Fig. 4.4(b) the highest value is obtained at $\langle 3, 3 \rangle$ subcarrier-pair, then it will be allocated for SU_1 with R_2 , SNR of each relay according to the allocated subcarriers are listed in Table-4.3.

Table-4.3 SNR of each relay for system model 1

SNR of R_1		SNR of R_2	
Subcarrier pairs	SNR values	Subcarrier pairs	SNR values
$\langle 1, 2 \rangle$	55.1365	$\langle 3, 3 \rangle$	60.873
$\langle 2, 4 \rangle$	5.31	$\langle 4, 1 \rangle$	1.43

4. The total data rate from the two relays is shown in Fig. 4.5. From the SNR in Fig. 4.4 we can calculate the total data rate shown in Fig. 4.5 from each node according to the Shannon theory mentioned in (3.12).

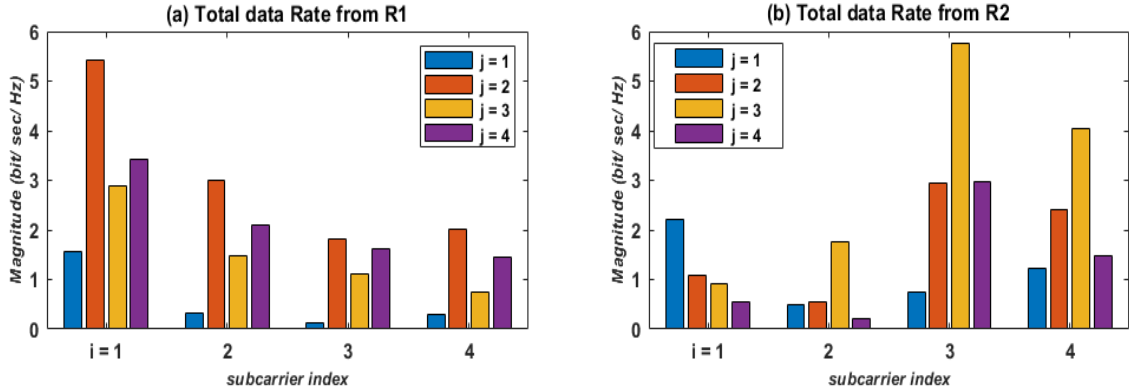

Fig. 4.5: Total data rate from each relay on all Subcarrier-pairs

The calculated data rates from each relay according to the allocated subcarriers are listed in Table-4.4.

$$Rate_1 = 0.5 \log_2(1 + SNR11) + 0.5 \log_2(1 + SNR21) \quad (4.1)$$

$$Rate_2 = 0.5 \log_2(1 + SNR12) + 0.5 \log_2(1 + SNR22) \quad (4.2)$$

Table-4.4: total data rate of each relay for system model 1

<i>Rate of R₁</i>		<i>Rate of R₂</i>	
Subcarrier pairs	<i>Rate values</i>	Subcarrier pairs	<i>Rate values</i>
<1 , 2 >	5.42672	<3 , 3 >	5.76676
<2 , 4 >	2.09849	<4 , 1 >	1.23926

Depending on subcarrier-allocation matrix A and the subcarrier-pairs, the highest individual value of data rate can be calculated:

$Rate_1 = 7.525 \text{ bit/s/Hz}$, $Rate_2 = 7.006 \text{ bit/s/Hz}$ then, the total data rate (bit/s/Hz) of this system model is the result of adding the two rates: $Total \text{ data rate} = 14.5312 \text{ bit/s/Hz}$.

To find the total transmission rate (bit/s) must be suggested a frequency band. This system model can respond in general for any wireless system.

4.1.2 Comparison between the Results of System Model 1 and System Model in ref. [10]

As mentioned earlier in chapter 1, the system model1 is adopted from ref [10]. By using GA in this system model to maximize the total transmission data rate, it is noticed that: the obtained total data rate in this system model was increased, compared with the total data rate obtained in ref [10] with perfect sensing.

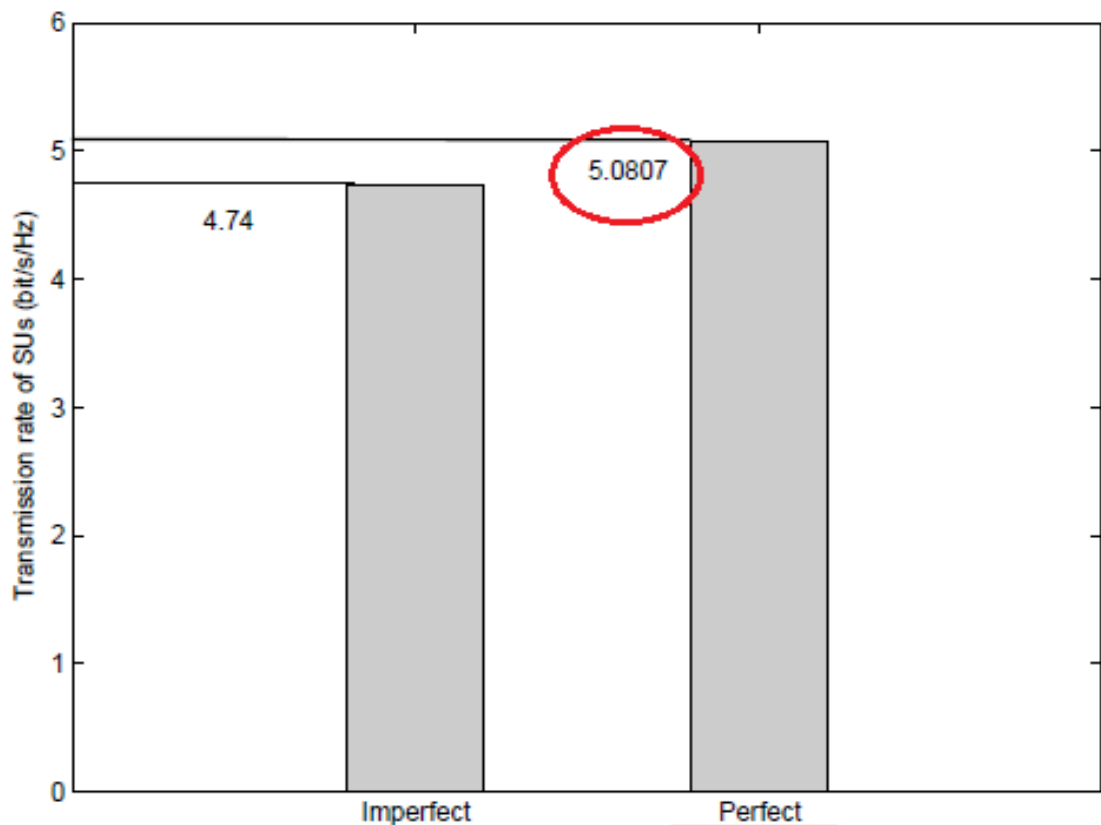

Fig. 4.6: Depicts the total capacity for perfect sensing for the system model in ref. [10] that compared with the total capacity for this system

knowing that in this system model the interference threshold imposed to ($I_{th} = 1 \times 10^{-6}$ watt) is much higher than the threshold imposed on the ref [10] ($I_{th} = 1 \times 10^{-12}$ watt). Figure 4.6 shows the total capacity for the perfect sensing for the system model in [10].

For system model1, if the interference threshold changed to $I_{th} = 1 \times 10^{-9}$, then the result will be equal to: $Rate_1 = 3.3858 \text{ bit/s/Hz}$, $Rate_2 = 13.5857 \text{ bit/s/Hz}$, where the total data rate of this model is the result of adding the two rates: $Total \ data \ rate = 16.9715 \text{ bit/s/Hz}$. From this result can notice that, the decreasing in the interference threshold will help to increase the total data rate of this system model.

4.2 Simulation Results for System Model 2

To maximize the total transmission-rate for secondary network and solve the optimization problems, GA is adopted to obtain jointly the results of the RA and relay selection. All parameters for GA and the power values that used in this system model are listed in Table 4.5.

Table-4.5: GA parameters and power values for System Model 2

number of iterations size data	10
number of initial generations data	500
total number of variables	($X_T = 40$)
power variables	($X_P = 20$), its range 256 levels
subcarrier variables	($X_F = 20$), binary range (0 or 1)
Maximum transmission power for secondary users	$p_{Si} = 1.5 \text{ watt}$
Maximum transmission power for relay nodes	$p_{kj} = 1.5 \text{ watt}$
interference power threshold	$I_{th} = 1 \times 10^{-6} \text{ watt}$
<i>AWGN</i>	zero-mean and ($\sigma^2 = 0.01$)

The adopted channel gains and interference-channel gains are i.i.d as $\mathcal{CN} \sim (\mu, \sigma^2)$ with zero mean [10].

The results for this system model are:

1. The subcarrier-pair matrix and relay selection matrix for each relay obtained from GA are:

$$A = \begin{bmatrix} 0 & 0 & 0 & 1 \\ 0 & 0 & 1 & 0 \\ 0 & 1 & 0 & 0 \\ 1 & 0 & 0 & 0 \end{bmatrix}$$

$$B1 = \begin{bmatrix} 0 & 1 & 0 & 0 \\ 0 & 1 & 0 & 0 \\ 0 & 1 & 0 & 0 \\ 0 & 1 & 0 & 0 \end{bmatrix}, \quad B2 = \begin{bmatrix} 1 & 0 & 1 & 1 \\ 1 & 0 & 1 & 1 \\ 1 & 0 & 1 & 1 \\ 1 & 0 & 1 & 1 \end{bmatrix}$$

$$A \times B1 = \begin{bmatrix} 0 & 0 & 0 & 0 \\ 0 & 0 & 0 & 0 \\ 0 & 1 & 0 & 0 \\ 0 & 0 & 0 & 0 \end{bmatrix}, \quad A \times B2 = \begin{bmatrix} 0 & 0 & 0 & 1 \\ 0 & 0 & 1 & 0 \\ 0 & 0 & 0 & 0 \\ 1 & 0 & 0 & 0 \end{bmatrix}$$

In matrix A : the rows represent the subcarriers- i while the columns represent the subcarriers- j . The values of ones in matrix A represent the subcarrier pairs $\langle i, j \rangle$, means that the subcarrier- i (when SU_s transmit to k^{th} relay) for phaseI which is paired with the subcarrier- j (when k^{th} relay transmit to SU_d) for phaseII. To distinguish the subcarrier pairs in matrix A which will allocated to R_1 or R_2 , by multiply each of B_1 and B_2 with matrix A (dot product). According to that, the subcarrier pair $\langle 3, 2 \rangle$ is allocated to $R1$ and the subcarrier pairs $\langle 1, 4 \rangle$, $\langle 2, 3 \rangle$ and $\langle 4, 1 \rangle$ are allocated to $R2$. All of subcarrier-pairs allocated to each relay are shown in Fig. 4.7.

2. The powers allocated for SU_s are calculated for all subcarriers- i of phaseI (when SU_s transmit to k^{th} relay) and calculated for relay nodes on all subcarriers- j of phaseII (when k^{th} relay transmit to SU_d), are shown in Fig. 4.8. Then, according to matrix A and the multiplication of ($A \times B_1$ and $A \times B_2$)

it will be find the powers allocated for each subcarrier pair $\langle i, j \rangle$. The power values of each sub carrier pairs are listed in Table-4.6.

Table-4.6: power values of each subcarrier pair for System Model 2

R_1		R_2	
Subcarrier pairs	Power values	Subcarrier pairs	Power values
$\langle 3, 2 \rangle$	0.1709w, 0.0587w	$\langle 1, 4 \rangle$	0.4338w, 1.1532w
---	---	$\langle 2, 3 \rangle$	0.4314w, 0.0247w
---	---	$\langle 4, 1 \rangle$	0.3179w, 0.0163w

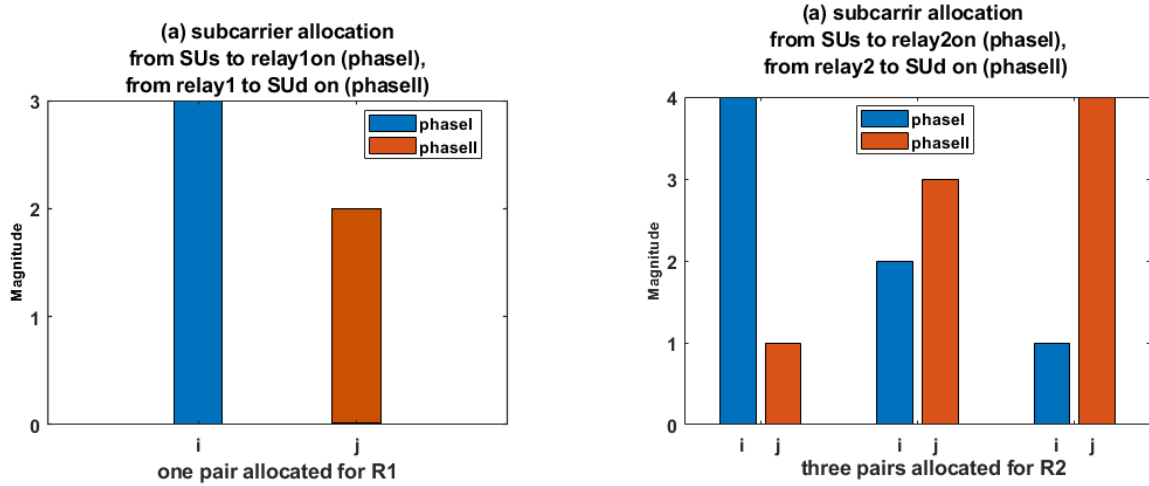
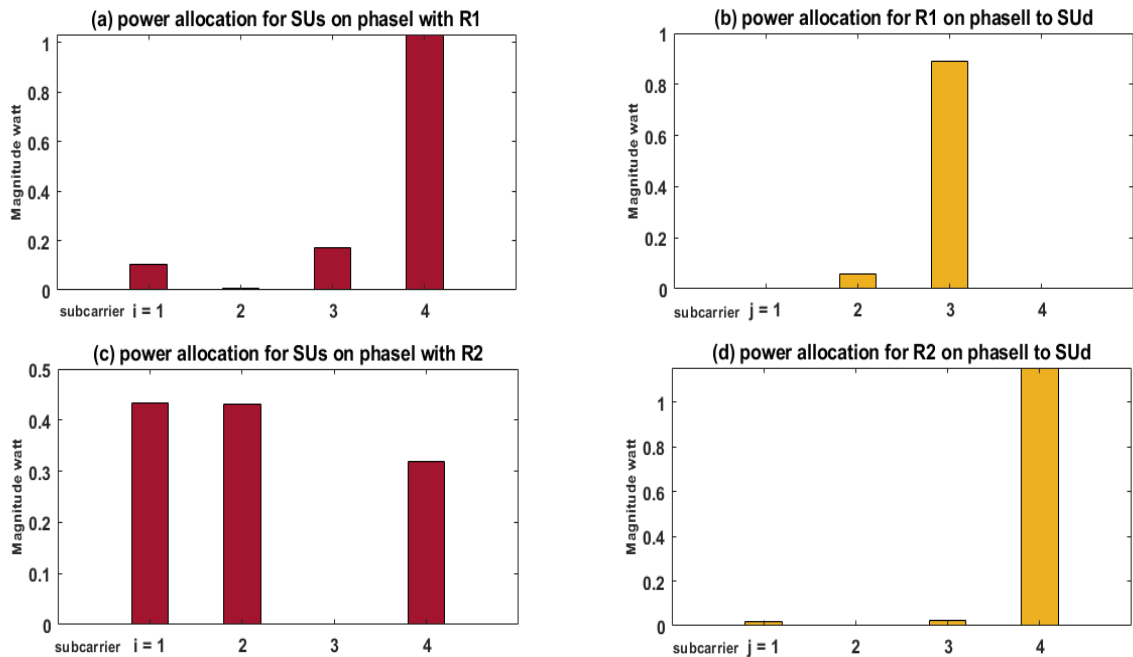

Fig. 4.7: Subcarrier Allocation for system model 2

3. The Signal to Noise ratio for SU_s with k^{th} relay are shown in Fig. 4.9. It can be noticed that, the SNR in fig 4.9 for phasel (from SU_s to R1) on each subcarrier pair is different in subcarrier i for all subcarriers j (subcarriers j are fixed), because the subcarrier j is not allocated yet, but in phasell it has a different SNR on subcarrier j for all subcarriers i (subcarriers i are also different) because they are allocated before in the first phase. The SNR for each relay node listed in Table-4.7:

Table-4.7: The SNR of each relay node for system model 2

SNR of R_1		SNR of R_2	
Subcarrier pairs	SNR values	Subcarrier pairs	SNR values
$\langle 3, 2 \rangle$	3.653	$\langle 1, 4 \rangle$	1.0238
---	---	$\langle 2, 3 \rangle$	0.462
---	---	$\langle 4, 1 \rangle$	3.6502

Fig. 4.8: Power Allocation for SU_s and for k^{th} relay on each subcarrier pairs

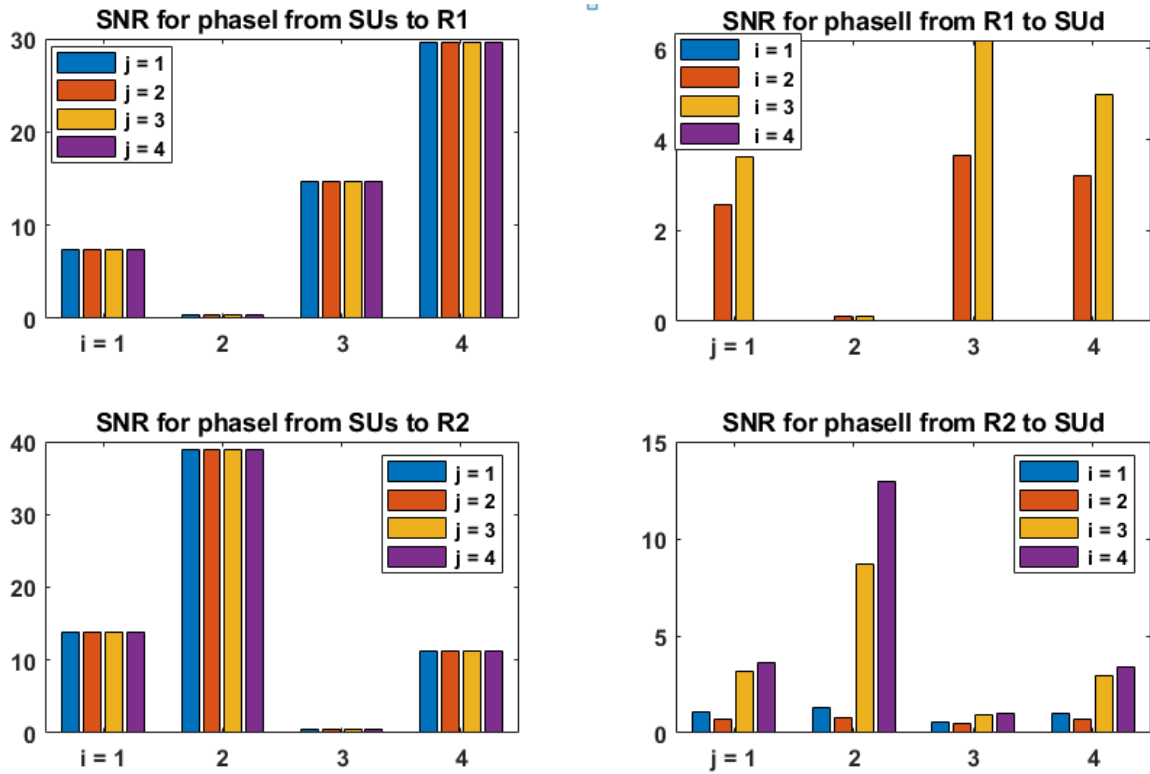

Fig. 4.9: SNR for each Subcarrier pair

4. The total data rate from the two relays is shown in Fig. 4.10. The data rates are calculated of each relay are listed in Table-4.8.

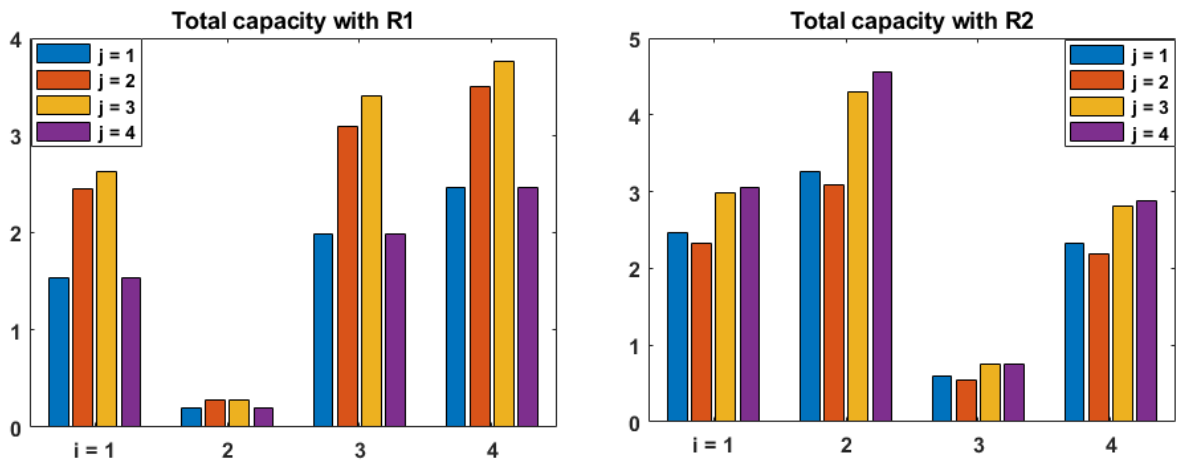

Fig. 4.10: The Total data rate from each relay

Table-4.8: transmission rate of each relay for system model 2

$Rate_1$		$Rate_2$	
Subcarrier pairs	SNR values	Subcarrier pairs	SNR values
<3 , 2 >	3.0963	<1 , 4 >	2.3185
---	---	<2 , 3 >	4.2968
---	---	<4 , 1 >	3.0557

According to (3.22), the total data rate (bit/s/Hz) can be calculated for each relay with secondary users (secondary network). Depending on subcarrier allocation matrix A and the subcarrier pairs the highest individual value of data rates are equal to:

$Rate_1 = 3.0963 \text{ bit/s/Hz}$, $Rate_2 = 9.6712 \text{ bit/s/Hz}$ then, the total data rate of this system model is result of adding the two rates: $Total \ data \ rate = 12.7675 \text{ bit/s/Hz}$.

For this model, the interference threshold is changed to $I_{th} = 1 \times 10^{-9}$, then the result also is changed to: $Rate_1 = 12.1136 \text{ bit/s/Hz}$, $Rate_2 = 4.9255 \text{ bit/s/Hz}$. The total data rate of this model is the result of adding the two rates: $Total \ data \ rate = 17.0391 \text{ bit/s/Hz}$. From this result it is noticed that: the decreasing in the interference threshold will help in increasing the total data rate of this system model.

4.3 Simulation Results for System Model 3

Particularly this section will find the optimized power allocated for the cognitive small cell users SUs and relay nodes, and sub-carrier pairing matrix to the maximization of the total data rate evaluated in numerical results of the implemented system model 3. All parameters for GA and the powers values used in this system model are listed in Table 4.9.

Table-4.9: GA parameters and power values for System Model 3

number of iterations size data	50
number of initial generations data	200
total number of variables	$(X_T = 48)$
power variables	$(X_P = 24)$, its range 256 levels
subcarrier variables	$(X_F = 24)$, binary range (0 or 1)
Maximum transmission power for secondary users	$p_{s\ max} = 1\ watt$
Maximum transmission power for relay nodes	$p_{r\ max} = 1\ watt$
Maximum transmission power for macro cell	$p_{MBS} = 1\ watt$
interference power threshold	1×10^{-9} watt
AWGN	zero-mean and 0.01 variance

Assuming the maximum transmission power of all elements ($p_{s\ max}$, $p_{r\ max}$, and p_{MBS}) be in normalized power that is equal to 1 watt, the adopted all channel gains and interference-channel gains are i.i.d as $\mathcal{CN} \sim (\mu, \sigma^2)$ with zero mean [10]. This is to guarantee the inter-carrier-interference that does not occur from carrier overlapping, assuming an offset constant randomly is between (0 and 1) for each subcarrier i and j [50].

The results for this system model:

1. The optimized sub-carrier pairing matrix and relay selection matrix for relay1 and relay2 are A, B1, and B2 respectively:

$$A = \begin{bmatrix} 1 & 0 & 0 & 0 \\ 0 & 0 & 1 & 0 \\ 0 & 0 & 0 & 1 \\ 0 & 1 & 0 & 0 \end{bmatrix}$$

$$B1 = \begin{bmatrix} 0 & 1 & 0 & 1 \\ 0 & 1 & 0 & 1 \\ 0 & 1 & 0 & 1 \\ 0 & 1 & 0 & 1 \end{bmatrix}, \quad B2 = \begin{bmatrix} 1 & 0 & 1 & 0 \\ 1 & 0 & 1 & 0 \\ 1 & 0 & 1 & 0 \\ 1 & 0 & 1 & 0 \end{bmatrix}$$

$$A \times B1 = \begin{bmatrix} 0 & 0 & 0 & 0 \\ 0 & 0 & 0 & 0 \\ 0 & 0 & 0 & 1 \\ 0 & 1 & 0 & 0 \end{bmatrix}, \quad A \times B2 = \begin{bmatrix} 1 & 0 & 0 & 0 \\ 0 & 0 & 1 & 0 \\ 0 & 0 & 0 & 0 \\ 0 & 0 & 0 & 0 \end{bmatrix}$$

Each number in matrix A represents the $\langle i, j \rangle$ pair. The rows represent the subcarrier $i = [1 \ 2 \ 3 \ 4]$ and the columns represent the subcarrier $j = [1 \ 2 \ 3 \ 4]$, when $A=1$ in the first row, meaning that the user uses the subcarrier ($i=1$) for sending to the k^{th} relay (of MA phase) and the k^{th} relay uses the subcarrier ($j=1$) for forwarding to user (of BC phase). The $B1, B2$ are the relay assignment matrix depending on matrix A . To determine which subcarrier pairs are assigned to R_1 or R_2 will be multiply matrix A by matrices $B2$, and $B1$, (dot product) respectively. That meaning, the $\langle 4, 2 \rangle$ pair is assigned to relay1, $\langle 3, 4 \rangle$ pair is assigned to relay1, $\langle 1, 1 \rangle$ pair is assigned to relay2, and $\langle 2, 3 \rangle$ pair is assigned to relay2. Figure 4.11 illustrates the subcarrier pair allocated for SU_1 with each relay and for SU_2 with each relay.

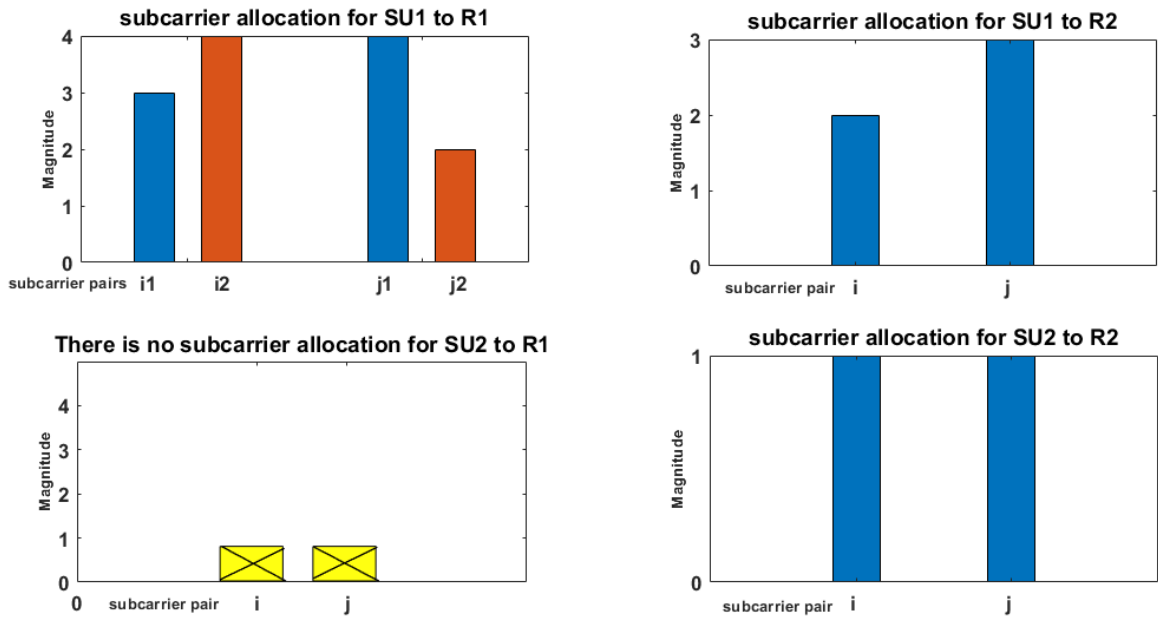

Fig. 4.11: Subcarrier Allocation for SU_s with each relay

2. The powers allocated for SU_s and Relay nodes are shown in Fig. 4.12 and 4.13 respectively. Figure 4.12 shows the transmit power allocation for MA phase from SUs on all subcarriers i to the relay nodes under the maximum power constraint which is equal to normalized power $p_{s\ max} = 1$ watt. Figure 4.13 show the power allocation from the relay nodes R_1 and R_2 for BC phase on all subcarriers j to SU_s under the maximum power constraint which is equal to normalized power $p_{r\ max} = 1$. From Fig. 4.13 and Fig. 4.14, the summation of all powers sent on each sub-carrier for each user and relay node does not exceed the maximum power. According to matrix A and the multiplication of $(A \times B_1$ and $A \times B_2)$, the powers allocation for each subcarrier pair of each relay are listed in Table-4.10.

Table-4.10: power values of each subcarrier pair for System Model 3

R_1		R_2	
Subcarrier pairs	Power values	Subcarrier pairs	Power values
$\langle 4, 2 \rangle$	0.02971w, 0.024w	$\langle 1, 1 \rangle$	0.0342w, 0.4109w
$\langle 3, 4 \rangle$	1.11 e-05w, 0.2028 w	$\langle 2, 3 \rangle$	0.0622w, 0.0431w

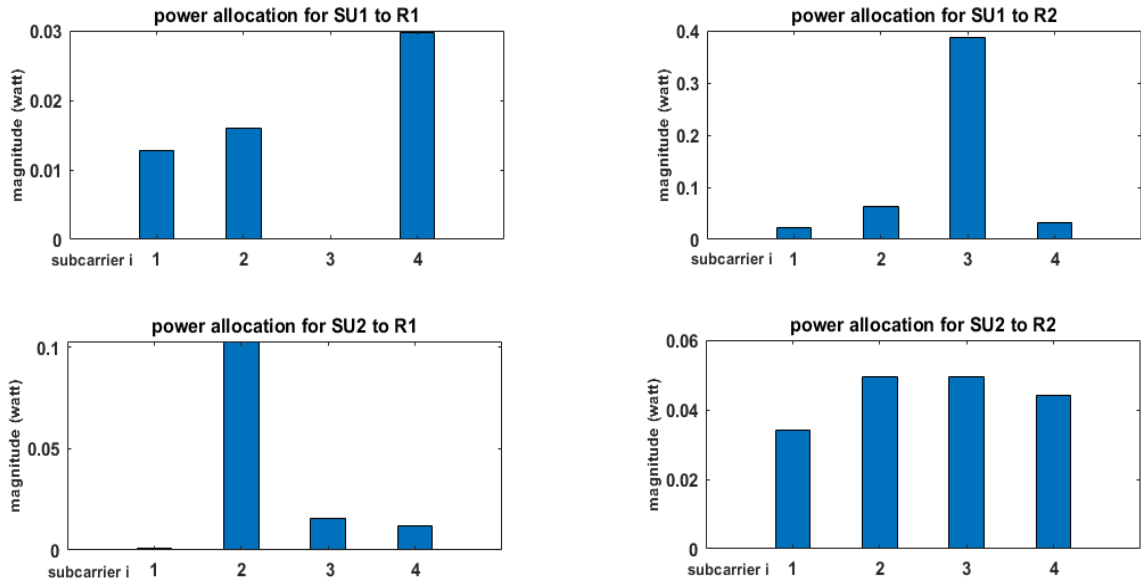

Fig. 4.12: Power Allocation for SU_s on all pairs under maximum power constraints

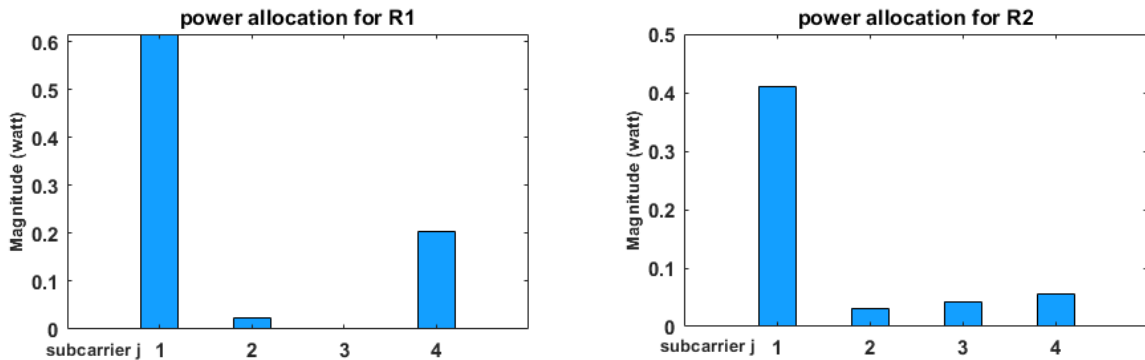

Fig. 4.13: Power Allocation for R_1 and R_2 under maximum power constraint

3. The signal to noise ratio SNR are shown in Fig. 4.14. To determine the pairs allocated to SU_1 or SU_2 depending on which have highest SNR from the other, therefore it is noticed that there is no subcarrier allocated from SU_2 to R_1 , but the path from SU_1 to R_2 takes two subcarrier pairs. Figure 4.14 shows the SNR to each $\langle i, j \rangle$ pair for both SU_1 to (R_1 and R_2) and for SU_2 to (R_1 and R_2) in MA phase with interference threshold constraint $I_{th} = 1 \times 10^{-9}$.

The SNR_{21} in Fig. 4.14 (c) at $i = 3$ is equal to zero for all subcarrier j , for this reason no subcarrier will be allocated in this path (from SU_2 to R_1) and all subcarrier pairs to R_1 will be allocated to SU_1 , because the values of SNR_{11} in Fig. 4.14 (a) at the pairs $\langle 3, 4 \rangle$ and $\langle 4, 2 \rangle$ are larger than SNR_{21} in Fig. 4.14 (c). The SNR values for each subcarrier pair of each relay are listed in Table-4.11.

Table-4.11 SNR of each relay for system model 3

SNR of R_1		SNR of R_2	
Subcarrier pairs	SNR values	Subcarrier pairs	SNR values
$\langle 4, 2 \rangle$	0.1257	$\langle 1, 1 \rangle$	0.061
$\langle 3, 4 \rangle$	0.4223	$\langle 2, 3 \rangle$	0.2122

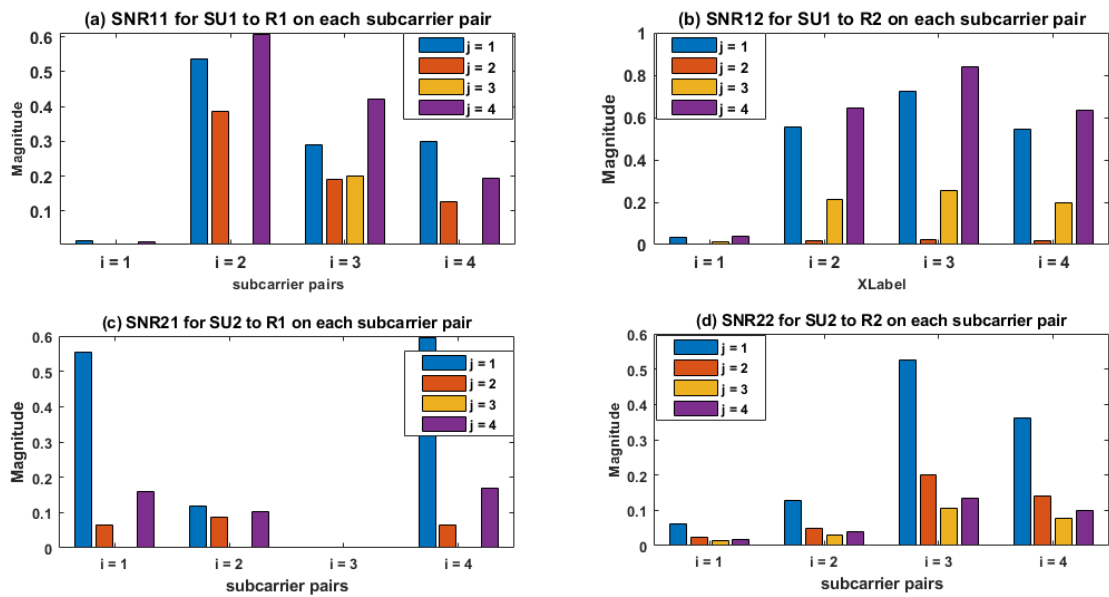
Fig. 4.14: SNR from SU_s on all subcarrier pairs with cross-tier interference

4. The total transmission data rates from each relay are shown in Fig. 4.15, it shows the total data rate (bit/s/Hz) for SU_s with R_1 and for SU_s with R_2 on each

subcarrier pairs, based on the signal noise ratio SNR , assuming that the relay used responds to any bandwidth. To obtain the total maximum transmission rate (bit/s), by suggest a bandwidth for this system model and compensate it in the Shannon law. The data rates are calculated for each subcarrier of each relay are listed in Table-4.12.

Table-4.12: Total transmission data rate of each relay for system model 3

Rate of R_1		Rate of R_2	
Subcarrier pairs	Rate value	Subcarrier pairs	Rate value
$\langle 4, 2 \rangle$	0.1331	$\langle 1, 1 \rangle$	0.0668
$\langle 3, 4 \rangle$	0.2726	$\langle 2, 3 \rangle$	0.1663

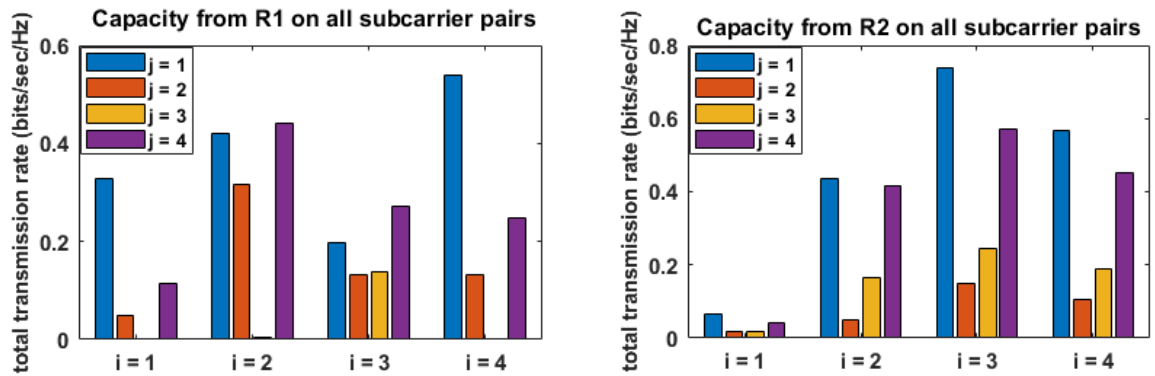

Fig. 4.15: Maximum data rate for SU_s with relay nodes R_1 and R_2 under maximum power constraint and interference threshold

According to (3.39), the result is equal to: $Rate_1 = 0.4666 \text{ bit/s/Hz}$, and $Rate_2 = 0.2605 \text{ bit/s/Hz}$. The total data rate of this system model is the result of adding the two rates: $Total \text{ transmission data rate} = 0.7271 \text{ bit/s/Hz}$.

For this system model, if the interference threshold is changed to $I_{th} = 1 \times 10^{-12}$, then the result will be equal to: $Rate_1 = 4.4606 \text{ bit/s/Hz}$, $Rate_2 = 0.6080 \text{ bit/s/Hz}$. The total data rate of this system model it is the result of adding the two rates: $Total \text{ transmission data rate} = 5.0686 \text{ bit/s/Hz}$. From this result, the decreasing in the interference threshold will help in increasing the total transmission data rate of this system model.

The total transmission data rates obtained for the all system models in this thesis are shown in this table-4.13.

Table-4.13: Total transmission data rates for all the system models

	Data rate (bit/s/Hz) with $I_{th} = 1 \times 10^{-6}$	Data rate (bit/s/Hz) with $I_{th} = 1 \times 10^{-9}$	Data rate (bit/s/Hz) with $I_{th} = 1 \times 10^{-12}$
System model 1	14.5312	16.9715	-----
System model 2	12.7675	17.0391	-----
System model 3	-----	0.7271	5.0686

Chapter 5

Conclusions and Future works

5.1 Conclusions

This thesis has addressed some optimization problems (resources allocation and relay selection) with all calculations under the power constraints and interference threshold.

To maximize the objective function is that maximization the total transmission data rate for the secondary network, when the primary network (license network) shares its licensed frequency band with the secondary network (unlicensed network).

Genetic Algorithm (GA) has been used in this thesis to maximize the objective function. The obtained results in this thesis can be summarized below:

1. The results have showed the ability of GA to effectively determine the frequency and power values of secondary network (users and relays).
2. Maximizing the total transmission rate for secondary network.
3. The total transmission rate will increase when the interference threshold value is decreased.
4. Increasing the spectrum efficiency by exploiting the vacant band (white holes) without any interference from secondary network to primary network.
5. Flexibility to allocate the power values because the power value is divided into 256 levels under the maximum power constrains.
6. The results indicate that the ability of this algorithm effectively determines the optimal frequency subcarrier and the suitable power assignment for secondary system's users.

5.2 Future works

A number of ideas can be added to the system models for this thesis. For example, the number of secondary users (SUs) can be increased and compete among them to exploit the empty holes in the licensed frequency spectrum. The competition depends on several factors including SU's speed and SU which is near or far from the primary network.

For the third model, the co-tier interference (caused from small cells that used the same frequency band) can be calculated and added to calculate the SINR.

For the three system models, other optimization algorithms can also be used to solve the formulation problems which can improve the results, by using the artificial intelligent (AI) to train the system models and get best results.

A non-orthogonal frequency division multiplexing technique can be proposed instead of the OFDM technique that is used in the system models.

References

- [1] Linda E. Doyle, "Essentials of Cognitive Radio", 1st edition, Cambridge University Press, ISBN: 052189770X, 2009.
- [2] Joseph Mitola, "Cognitive Radio Architecture: The Engineering Foundations of Radio XML", Wiley, ISBN: 0471742449, 2006.
- [3] HÜSEYİN ARSLAN, "Cognitive Radio, Software Defined Radio, and Adaptive Wireless Systems", 1st edition, Springer, ISBN: 1402055412, 2007.
- [4] Youping Zhao, Lizdabel Morales, Joseph Gaeddert, Kyung K. Bae, Jung-Sun Um, and Jeffrey H. Reed, "Applying Radio Environment Maps to Cognitive Wireless Regional Area Networks", 2nd IEEE International Symposium on New Frontiers in Dynamic Spectrum Access Networks, Dublin, Ireland, June 2007.
- [5] "ISO/IEC/IEEE International Standard", IEEE std.802.22-2011, May 2015.
- [6] Xueyi Li, Qi Zhang, Guangchi Zhang, and Jiayin Qin, "Joint Power Allocation and Subcarrier Pairing for Cooperative OFDM AF Multi-Relay Networks, "IEEE COMMUN. LETT., Vol. 17, No. 5, pp. 872 – 875, MAY 2013.
- [7] Ahmad Alsharoa, Faouzi Bader, and Mohamed-Slim Alouini, "Relay Selection and Resource Allocation for Two-Way DF-AF Cognitive Radio Networks, "IEEE WIRELESS COMMUN. LETT., Vol. 2, No. 4, pp. 427 – 430, AUGUST 2013.
- [8] Hung-Sheng Lang, Shih-Chun Lin, and Wen-Hsien Fang, "Subcarrier Pairing and Power Allocation with Interference Management in Cognitive Relay Networks Based on Genetic Algorithms", IEEE Transactions on Vehicular Technology, Vol. 65, No. 9, pp. 7051 – 7063, 2016.

- [9] Bo Chen, Ming Lei, Minjian Zhao, "An Optimal Resource Allocation Method for Multi-user Multi-relay DF Cognitive Radio Networks, "IEEE Communications Letters, Vol. 20, No. 6, pp. 1164 – 1167, June 2016.
- [10] Hangqi Li, Xiaohui Zhao," Joint Resource Allocation for OFDM-Based Cognitive Two-Way Multiple AF Relays Networks with Imperfect Spectrum Sensing, "IEEE Transactions on Vehicular Technology, Vol. 67, No. 7, pp. 6286 – 6300, July 2018.
- [11] Haesik Kim and Aarne Mammela, " Cognitive Communications", Wiley, ISBN: 9781118360316, July 2012.
- [12] Liang Liang, Gang Feng and Yunjian Jia, "Game-Theoretic Hierarchical Resource Allocation for Heterogeneous Relay Networks", IEEE transactions on vehicular technology, Vol. 64, No. 4, pp. 1480-1492, April 2015.
- [13] Zhengchuan Chen, Tao Li, Pingyi Fan, Tony Q.S. Quek and Khaled B. Letaief, "Cooperation in 5G Heterogeneous Networking: Relay Scheme Combination and Resource Allocation", IEEE transactions on communications, Vol. 64, No. 8, pp. 3430-3443, August 2016.
- [14] Tapas Kumar Patra and Albert Sunny, "Forwarding in Heterogeneous Mobile Opportunistic Networks", IEEE communications letters, Vol. 22, No. 3, pp. 626-629, March 2018.
- [15] Li Li , Changqing Xu , Meixia Tao, " Resource Allocation in Open Access OFDMA Femtocell Networks", IEEE wireless communications letters, Vol. 1, No. 6, pp. 625 – 628, December 2012.
- [16] Lei Zhang, Tao Jiang and Kai Luo, " Dynamic Spectrum Allocation for the Downlink of OFDMA-Based Hybrid Access Cognitive Femtocell Networks", IEEE transactions on vehicular technology, Vol. 65, No. 3, pp. 1772-1781, 2016.

- [17] Hyunsung Park and Taewon Hwang, " Energy-Efficient Power Control of Cognitive Femto Users for 5G Communications", IEEE journal on selected areas on communications, Vol. 34, No. 4, pp. 772-785, 2016.
- [18] Tuan LeAnh, Nguyen H. Tran, Sungwon Lee, Eui-Nam Huh, Zhu Han, and Choong Seon Hong, " Distributed Power and Channel Allocation for Cognitive Femtocell Network Using a Coalitional Game in Partition-Form Approach", IEEE transactions on vehicular technology, Vol. 66, No. 4, pp. 3475-3490, 2017.
- [19] Zhixin Liu, Yazhou Yuan, Huanhuan Yuan, and Xiping Guan, " Power Allocation Based on Proportional-Integral Controller in Femtocell Networks With Consideration of Maximum Power Constraint", IEEE Systems journal, Vol. 13, No. 1, pp. 88-97, 2019.
- [20] Mohammad A. Matin, "Spectrum Access and Management for Cognitive Radio Networks", 1st edition, Springer, ISBN 978-981-10-2253-1, 2017.
- [21] Ian F. Akyildiz, Won-Yeol Lee, Mehmet C. Vuran, and Shantidev Mohanty, "A Survey on Spectrum Management in Cognitive Radio Networks", IEEE communication magazine, Vol. 46, No. 4, pp. 40-48, April 2008.
- [22] Partha Pratim Bhattacharya, Ronak Khandelwal, Rishita Gera and Anjali Agarwal, "Smart Radio Spectrum Management for Cognitive Radio", International Journal of Distributed and Parallel Systems (IJDPS), Vol.2, No.4, July 2011.
- [23] Badr Benmammar, Asma Amraoui and Francine Krief, "A Survey on Dynamic Spectrum Access Techniques in Cognitive Radio Networks", International Journal of Communication Networks and Information Security (IJCNIS), Vol. 5, No. 2, August 2013.
- [24] Mehdi Seyfi, Sami Muhaidat and Jie Liang, " Relay selection in cognitive radio networks with interference constraints", Institution of Engineering and Technology (IET), Vol. 7, No. 10, pp. 922-930, August 2013.

- [25] Edward C. Van Der Meulen, "Three-Terminal Communication Channels", *Advances in Applied Probability*, Vol. 3, No. 1, pp. 120-154, 1971.
- [26] Leonardo Jiménez Rodríguez, Nghi Tran and Tho Le-Ngoc, "Amplify-and-Forward Relaying in Wireless Communications", 1st edition, Springer, ISBN 978-3-319-17981-0, 2015.
- [27] Xiaodong Ji, Baoyu Zheng, Yueming Cai, and Li Zou, " On the Study of Half-Duplex Asymmetric Two-Way Relay Transmission Using an Amplify-and-Forward Relay", *IEEE transactions on vehicular technology*, Vol. 61, No. 4, pp. 1649-1664, May 2012.
- [28] Chang-Lin Chen, and Che Lin, " Utility Maximization for Two-Way AF Relaying Under Rate Outage Constraints", *IEEE transactions on wireless communications*, Vol. 16, No. 9, pp. 5762-5778, sep. 2017.
- [29] Mohammad Torabi, David Haccoun, and Jean-François Frigon, " Relay Selection in AF Cooperative Systems: An Overview", *IEEE vehicular technology magazine*, Vol. 7, No. 4, pp. 104-113, Dec.2012.
- [30] Javad Haghghat and Walaa Hamouda, " Decode-Compress-and-Forward with Selective-Cooperation for Relay Networks", *IEEE communications letters*, Vol. 16, No. 3, pp. 378-381, March 2012.
- [31] D. Li, "Outage probability of cognitive radio networks with relay selection", *Institution of Engineering and Technology (IET) communications*, Vol. 5, No. 18, pp. 2730-2735, Dec. 2011.
- [32] P. Ubaidulla, and Sonia Aïssa, "Optimal Relay Selection and Power Allocation for Cognitive Two-Way Relaying Networks", *IEEE wireless communications letters*, Vol. 1, No. 3, June 2012.
- [33] Daniel Benevides da Costa and Sonia Aïssa, "Cooperative Dual-Hop Relaying Systems with Beamforming over Nakagami-m Fading Channels", *IEEE transactions on wireless communications*, Vol. 8, No. 8, pp. 3950-3954, August 2009.

- [34] Aria Nosratinia, Todd E. Hunter, Ahmadreza Hedayat, "Cooperative Communication in Wireless Networks", IEEE communications magazine, Vol. 42, No. 10, pp. 74-80, Oct. 2004.
- [35] Yi Zhao, Raviraj Adve, and Teng Joon Lim, "Improving Amplify-and-Forward Relay Networks: Optimal Power Allocation versus Selection", IEEE transactions on wireless communications, Vol. 6, No. 8, pp. 3114-3123, August 2007.
- [36] Sushant Sharma, Yi Shi, Y. Thomas Hou, and Sastry Kompella, "An Optimal Algorithm for Relay Node Assignment in Cooperative Ad Hoc Networks", IEEE/ACM Transactions on Networking, Vol. 19, No. 3, pp. 879-892, 2011.
- [37] Liying Li, Xiangwei Zhou, Hongbing Xu, Geoffrey Ye Li, Dandan Wang, and Anthony Soong, "Simplified Relay Selection and Power Allocation in Cooperative Cognitive Radio Systems", IEEE transactions on wireless communications, Vol. 10, No. 1, pp. 33-36, January 2011.
- [38] Peng Li, Song Guo, Weihua Zhuang, and Baoliu Ye, "On Efficient Resource Allocation for Cognitive and Cooperative Communications", IEEE journal on Selected Areas in Communications, Vol. 32, No. 2, pp. 264-273, Feb. 2014.
- [39] Yunxiang Jiang, Francis C.M. Lau, Ivan W.H. Ho, and Yi Gong, "Resource Allocation for Multi-User OFDMA Hybrid Full-/Half-Duplex Relaying Systems With Direct Links", IEEE transactions on vehicular technology, Vol. 65, No. 8, pp. 6101-6118, Aug. 2016.
- [40] Yuan Liu and Meixia Tao, "Optimal Channel and Relay Assignment in OFDM-Based Multi-Relay Multi-Pair Two-Way Communication Networks", IEEE Transactions on Communications, Vol. 60, No. 2, pp. 317-321, Feb. 2012.
- [41] Ramjee Prasad, "OFDM for Wireless Communications Systems", Artech House, ISBN 1580537960, 2004.
- [42] Samuel C. Yang, "OFDMA System Analysis and Design", 1st edition, Artech House, ISBN 160807076X, 9781608070763, 2010

- [43] Huseyin Arslan, Hisham A. Mahmoud, and Tefvik Yucek, " OFDM for Cognitive Radio: Merits and Challenges, chapter 11 from Cognitive Radio, Software Defined Radio, and Adaptive Wireless Systems", 1st edition, Springer, ISBN: 1402055412, 2007.
- [44] Xavier Fernando, Ajmery Sultana, Sattar Hussain and Lian Zhao, "Cooperative Spectrum Sensing and Resource Allocation Strategies in Cognitive Radio Networks", 1st edition, Springer, ISBN 978-3-319-73956-4, 2019.
- [45] Muhammad Naeem, Alagan Anpalagan, Muhammad Jaseemuddin and Daniel C. Lee, "Resource Allocation Techniques in Cooperative Cognitive Radio Networks", IEEE communications surveys and tutorials, Vol. 16, No. 2, pp. 729-744, 2014.
- [46] Manal El Tanab and Walaa Hamouda, " Resource Allocation for Underlay Cognitive Radio Networks: A Survey", IEEE communications surveys and tutorials, Vol. 19, No. 2, pp. 1249-1276, 2017.
- [47] Subhadip Samanta , "Genetic Algorithm: An Approach for Optimization (Using MATLAB) ", International Journal of Latest Trends in Engineering and Technology (IJLTET) , Vol. 3, No. 3, January 2014.
- [48] A. J. Chipperfield and P. J. Fleming, "The MATLAB Genetic Algorithm Toolbox", IEE Colloquium on Applied Control Techniques Using MATLAB Conference published in IET, London, UK, 26-26 Jan. 1995.
- [49] Subhasree Bhattacharjee, Amit Konar and Atulya K. Na gar, "Channel Allocation for a Single Cell Cognitive Radio Network Using Genetic Algorithm", Fifth International Conference on Innovative Mobile and Internet Services in Ubiquitous Computing, Seoul, South Korea, 30 June-2 July 2011.
- [50] Tianming Ma, "A new inter-carrier interference self-cancellation mapping scheme over fast time-varying fading channels", Institution of Engineering and Technology (IET), Vol. 53, No. 21, pp. 1433-1435, 2017.

List of publications

1. "Maximum Rate for OFDM based Cognitive two-way AF-Relay Network with joint Resources Allocation and Relay selection"

Accepted in the International Conference for Information Technology, engineering and Science (ICOITES) Conference, by Kufa University.

2. "Power Allocation, Subcarrier Allocation and Relay Selection with Interference Managements for OFDM-based Small Cells Cognitive Relay Heterogeneous Networks"

Under Review

أاللاة

شبكة الترحيل المعرفية هي عبارة عن دمج تقنيتي الشبكة المعرفية الراديوية مع المرحلات اللاسلكية. هناك مجموعة من التحديات او المشاكل التي تواجه هذا الدمج و هي مشكلة تخصيص الموارد (تخصيص القدرة و تخصيص الحوامل الفرعية)، مشكلة ادارة التداخل، واختيار المرحل للشبكة مع الاخذ بنظر الاعتبار اهم المحددات التي تمنع التداخل مع المستخدم الاصلي.

في هذه الرسالة، اقترحت نماذج لشبكة الترحيل المعرفية (CRN) و الهدف من هذه الدراسة هو تعظيم نقل البيانات للشبكة الثانوية التي تتكون من (مستخدمين ثانويين مع مجموعة مرحلات لاسلكية). هذه النماذج اعتمدت استخدام تقسيم التردد المتعامد على شبكة الترحيل المعرفية مع مجموعة من المستخدمين الثانويين لتحسين من كفاءة الطيف الترددي. ثم طبقت نفس مشاكل التحسين على مجموعة من الخلايا الصغيرة بداخل خلية اكبر في النظام الخليوي للشبكات الغير المتجانسة، مع حساب التداخل المؤثر من الخلية الكبيرة على مستخدمي الخلايا الصغيرة.

الخوارزمية الجينية (GA) استخدمت لحل مشاكل التحسين أظهرت النتائج قدرة عالية لهذه الخوارزمية لتحديد القناة الفرعية (الموجة الحاملة الفرعية) وتعيين القدرة بشكل فعال ، وزيادة السعة الإجمالية للشبكة الثانوية. أعلى معدلات بيانات الإرسال الإجمالية التي تم الحصول عليها من نماذج النظام هذه هي (5.0686،17.0391،16.9715) bit / sec / Hz. يتم محاكاة النتائج باستخدام

برنامج الماتلاب 2018b.MATLAB



جمهورية العراق
وزارة التعليم العالي والبحث
العلمي
جامعة الفرات الاوسط التقنية
الكلية التقنية الهندسية- نجف



تقنية التحسين المعتمدة على الخوارزمية الجينية لشبكات الترحيل المعرفي

رسالة مقدمة الى

قسم هندسة تقنيات الاتصالات

كجزء من متطلبات نيل درجة ماجستير تقني في هندسة الاتصالات

تقدمت بها

بان خالد عمار

بكالوريوس في هندسة تقنيات الاتصالات

إشراف

الأستاذ المساعد الدكتور حيدر جواد محمد

الأستاذ المساعد الدكتور أحمد غانم وداي

أيلول / 2019