

CHAPTER 6

POWER LAUNCHING AND COUPLING

Launching optical power from source into fiber needs following considerations:

Fiber parameters:

- Numerical aperture
- Core size
- Refractive index profile
- Core cladding index difference

Source parameters:

- Size
- Radiance
- Angular power distribution

Coupling efficiency:

It is the measure of the amount of optical power emitted from a source that can be coupled into a fiber .

$$= P_F / P_S$$

P_F = Power coupled into the fiber

P_S = Power emitted from the light source

Coupling efficiency depends on:

1. Type of fiber that is attached to the source
2. Coupling Process (e.g. lenses or other coupling improvement schemes)

Flylead / Pigtail:

Short length of optical fiber attached with the source for best power coupling configuration.

Thus

Power launching problem for these pigtailed sources reduces to a simpler coupling optical power from one fiber to another.

Effects to be considered in this case include:

1.Fiber misalignments:

- a. Different core sizes
- b. Numerical apertures
- c. Core refractive index profiles

2.Clean and smooth fiber end faces:

- a) perfectly perpendicular to the axis
- b) Polished at a slight angle to prevent back reflections



Optical fiber receptacles:

An alternate arrangement consist of light sources and optical fiber receptacles that are integrated within a transceiver package.

Fiber connector from a cable is simply mated to the built in connector in the transceiver package.

Commercially available configurations are the popular small form factor (SFF) and the SFF pluggable (SFP) devices.



Photodiode, PIN, 1310/1550 nm,
LC, SC or FC Receptacle



SFP ,Transceiver, 155 Mb/s STM-1

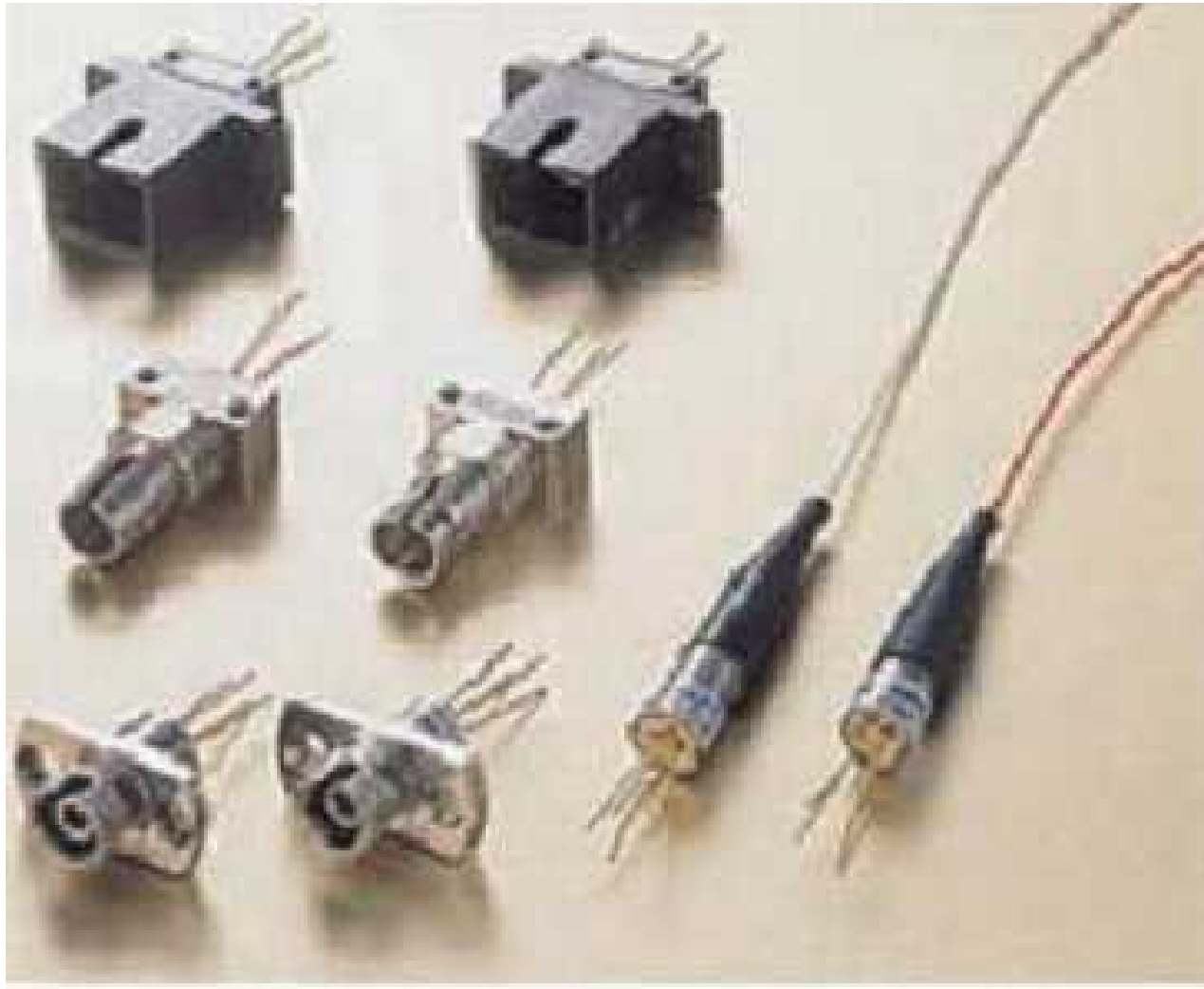

Laser diodes with pigtails and Receptacle

Source to fiber power launching

Optical output of a luminescent source is usually measured by its **radiance B** at a given diode current.

Radiance: It is the optical power radiated into a unit solid angle per unit emitting surface area and is generally specified in terms of watts per square centimeter per steradian.

Radiance = Power / per unit solid angle x per unit emitting surface area

Solid angle is defined by the projected area of a surface patch onto a unit sphere of a point.

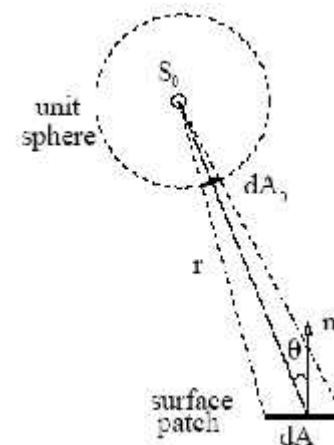
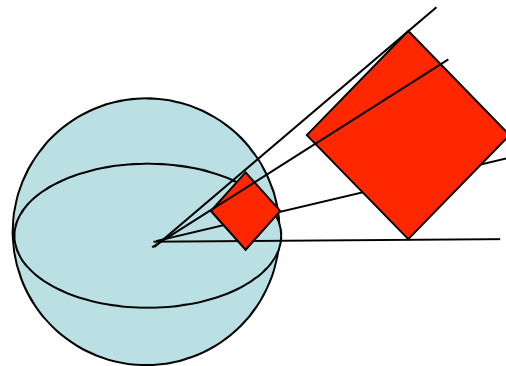

The angle that, seen from the center of a sphere, includes a given area on the surface of that sphere. The value of the solid angle is numerically equal to the size of that area divided by the square of the radius of the sphere

Radiance (Brightness) of the source

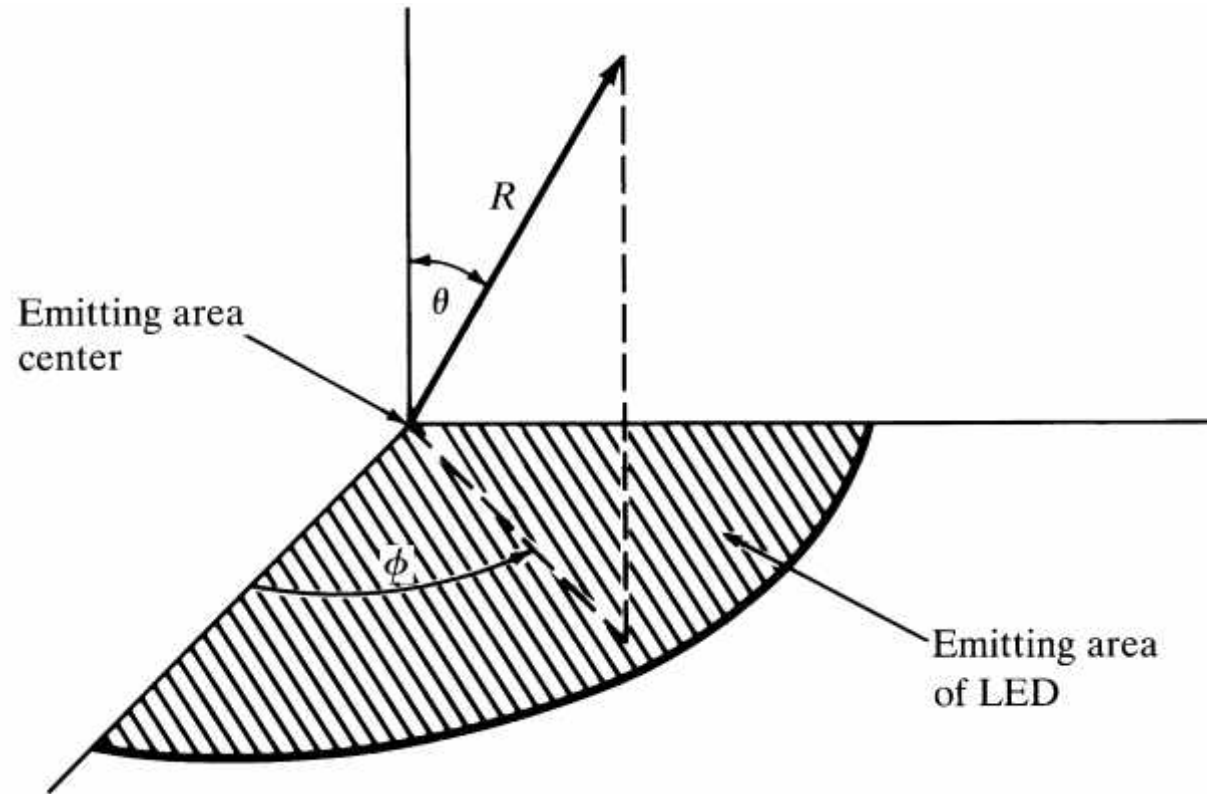

- $B =$ Optical power radiated from a unit area of the source into a unit solid angle [watts/(square centimeter per steradian)]

Surface emitting LEDs have a Lambertian pattern:

$$B(\theta, \phi) = B_0 \cos \theta \quad [5-2]$$

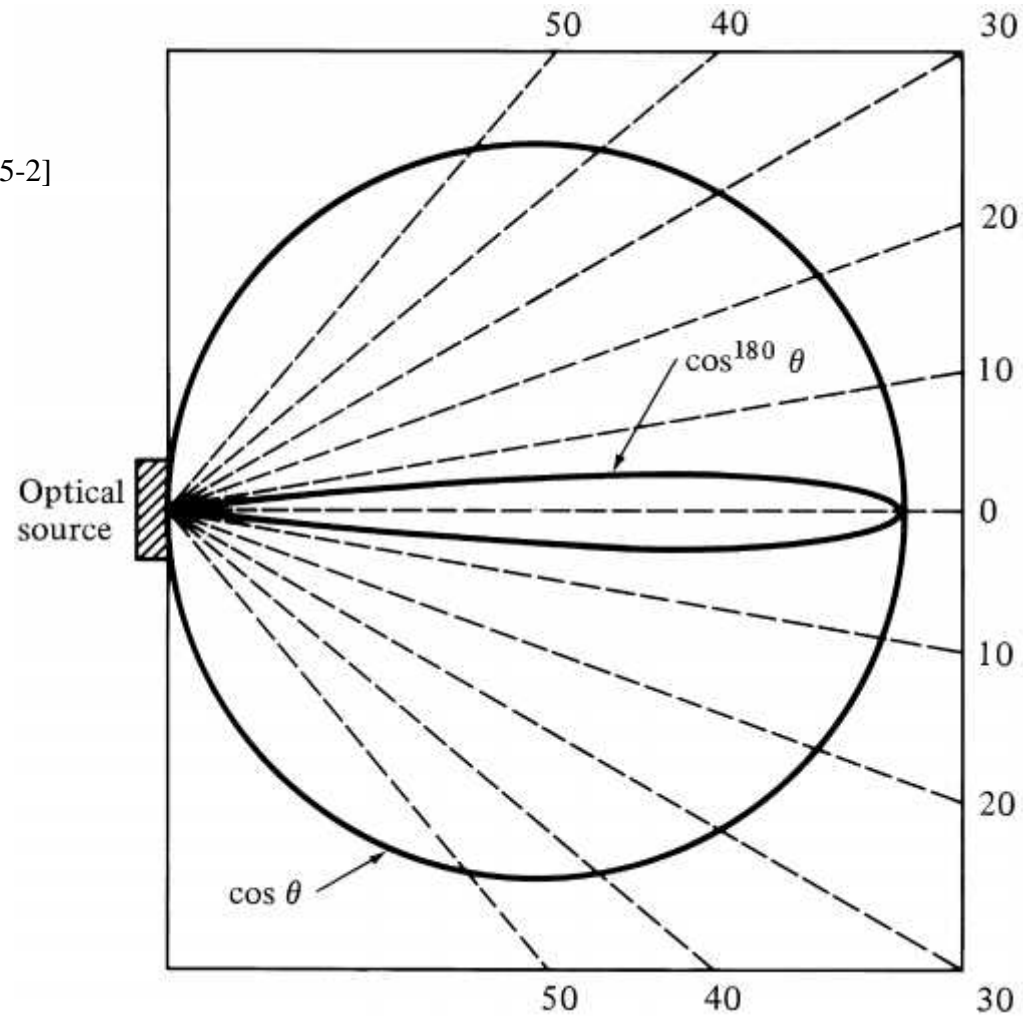

Edge emitting LEDs and laser diodes radiation pattern

$$\frac{1}{B(\theta, \phi)} = \frac{\sin^2 \theta}{B_0 \cos^T \theta} + \frac{\cos^2 \theta}{B_0 \cos^L \theta} \quad [5-3]$$

For edge emitting LEDs, $L=1$

Power Coupled from source to the fiber

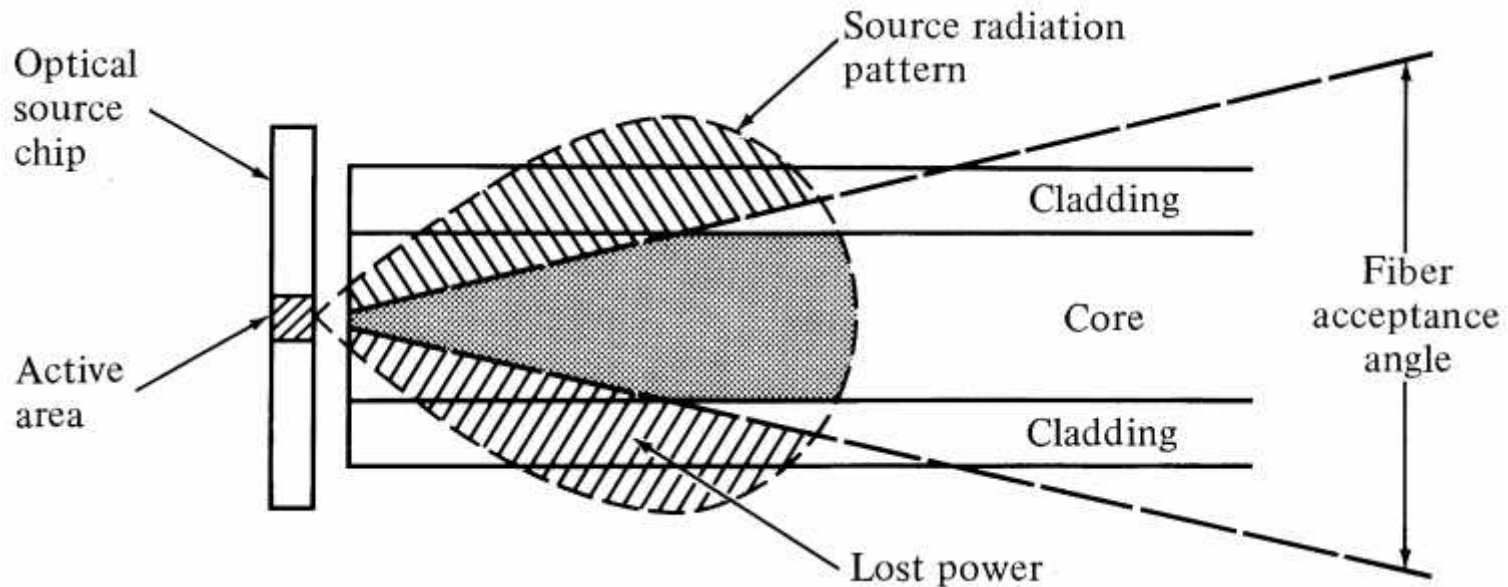

A_s and Ω_s : area and solid emission angle of the source

$$P_F = \int_{A_f} \left[\int_{\Omega_f} B(A_s, \Omega_s) d\Omega_s \right] dA_s = \quad [5-4]$$

A_f and Ω_f : area and

solid acceptance angle of fiber

$$= \int_0^{r_m} \int_0^{2f} \left[\int_0^{2f} \int_0^{\theta_{\max}} B(r, \theta) \sin \theta d\theta d\phi \right] dA_s r dr$$

Power coupled from LED to the Fiber

$$\begin{aligned}
 P &= \int_0^{r_s} \int_0^{2f} \left(2f B_0 \int_0^{\theta_{\max}} \cos \theta \sin \theta d\theta \right) d\theta_s r dr \\
 &= f B_0 \int_0^{r_s} \int_0^{2f} \sin^2 \theta_{\max} d\theta_s r dr \\
 &= f B_0 \int_0^{r_s} \int_0^{2f} \text{NA}^2 d\theta_s r dr
 \end{aligned}$$

$$P_{\text{LEDstep}} = f^2 r_s^2 B_0 (\text{NA})^2 \approx 2f^2 r_s^2 B_0 n_1^2 \Delta$$

[5-5]

Power coupling from LED to step-index fiber

- Total optical power from LED:

$$P_s = A_s \int_0^{2f} \int_0^{f/2} B(\theta, \phi) \sin \theta d\theta d\phi$$

$$P_s = f r_s^2 2f B_0 \int_0^{f/2} \cos \theta \sin \theta d\theta = f^2 r_s^2 B_0 \quad [5-6]$$

$$P_{\text{LED,step}} = \left\{ \begin{array}{ll} P_s (\text{NA})^2 & \text{if } r_s \leq a \\ \left(\frac{a}{r_s} \right)^2 P_s (\text{NA})^2 & \text{if } r_s \geq a \end{array} \right\} \quad [5-7]$$

Power coupling from LED to graded-index fiber

- Power coupled from the LED to the graded indexed fiber is given as

$$P_{LED,gin} = 2f^2 B_o \int_0^{r_s} [n^2(r) - n_2^2] r dr$$
$$= 2P_s n_1^2 \Delta \left[1 - \frac{2}{r+2} \left(\frac{r_s}{a} \right)^r \right]$$

- If the medium between source and fiber is different from the core material with refractive index n , the power coupled into the fiber will be reduced by the factor

$$R = \left(\frac{n_1 - n}{n_1 + n} \right)^2$$

Power Launching Vs Wavelength

- Optical power only depends on the radiance and not on the wavelength of the mode. For a graded index fiber number of modes is related to the wavelength as

$$M = \frac{r}{r + 2} \left(\frac{2fan_1}{\lambda} \right)^2 \Delta$$

- So twice as many modes propagate for 900 nm as compared to 1300 nm but the radiated power per mode from a source is

$$\frac{P_s}{M} = B_o \lambda^2$$

- So twice as much power is launched per mode for 1300nm as compared to the 900nm

Equilibrium Numerical aperture

- For fibers with flylead attachments the connecting fiber should have the same NA. A certain amount of loss occurs at this junction which is almost 0.1 – 1dB. Exact loss depends on the connecting mechanism.
- Excess power loss occurs for few tens of meters of a multimode fiber as the launched modes come to the equilibrium.
- The excess power loss is due to the non propagating modes
- The loss is more important for SLED.
- Fiber coupled lasers are less prone to this effect as they have very few non propagating modes.
- The optical power in the fiber scales as

$$P_{eq} = P_{50} \left(\frac{NA_{eq}}{NA_{in}} \right)^2$$

Equilibrium Numerical Aperture

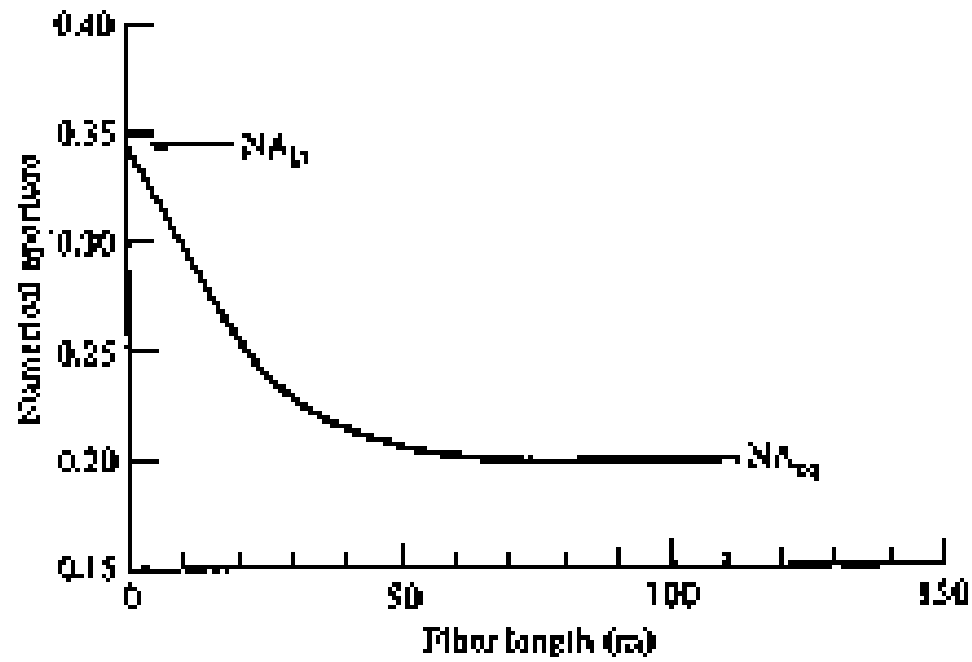

Lensing Scheme for Coupling Improvement

Several Possible lensing schemes are:

1. Rounded end fiber
2. Nonimaging Microsphere (small glass sphere in contact with both the fiber and source)
3. Imaging sphere (a larger spherical lens used to image the source on the core area of the fiber end)
4. Cylindrical lens (generally formed from a short section of fiber)
5. Spherical surfaced LED and spherical ended fiber
6. Taper ended fiber.

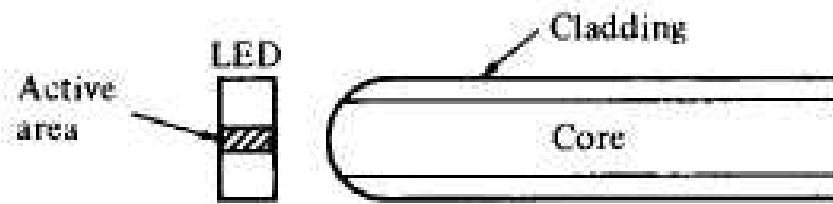

Rounded-end fiber

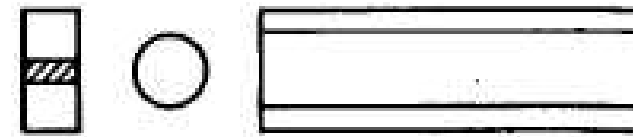

Nonimaging microsphere

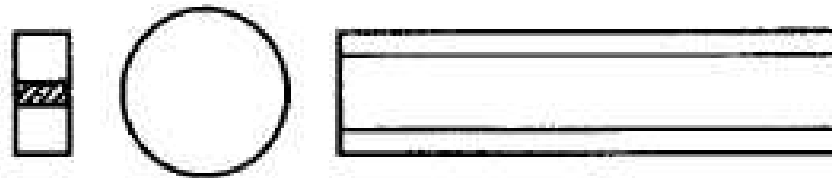

Imaging sphere

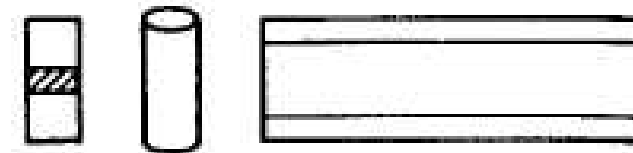

Cylindrical lens



Spherical-surfaced LED and spherical-ended fiber

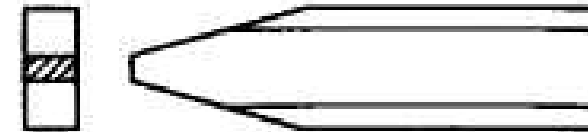

Taper-ended fiber

Examples of possible lensing scheme used to improve optical source to fiber coupling efficiency

Lensing Scheme for Coupling Improvement

Problem in using lens:

One problem is that the lens size is similar to the source and fiber core dimensions, which introduces fabrication and handling difficulties.

In the case of taper end fiber, the mechanical alignment must be carried out with great precision

Non Imaging Microsphere

- Use for surface emitter is shown
- Assumptions: refractive indices shown in the fig. and emitting area is circular
- To collimate the output from the LED, the emitting surface should be located at the focal point of the lens which can be found as

$$\frac{n}{s} + \frac{n'}{q} = \frac{n' - n}{r}$$

- Where s and q are object and image distances as measured from the lens surface, n is the refractive index of the lens, n' is the refractive index of the outside medium and r is the radius of curvature of the lens surface

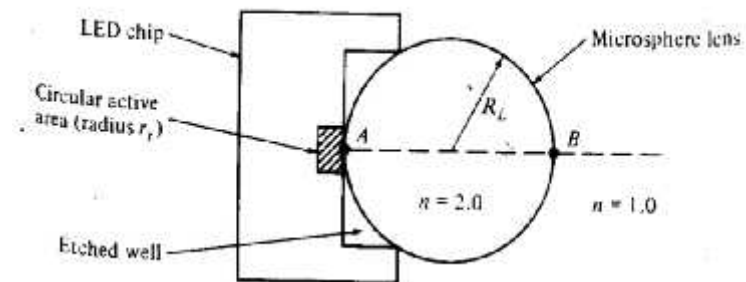

continued

The following sign conventions are used

1. Light travels from left to right
2. Object distances are measured as positive to the left of a vertex and negative to the right
3. Image distances are measured as positive to the right of a vertex and negative to the left
4. All convex surfaces encountered by the light have a positive radius of curvature, and concave surfaces have a negative radius.

For these conventions, we can find the focal point for the right hand surface of the lens shown in the last fig. We set $q = \text{infinity}$, solve for s yields

$$s = f = 2R_L$$

So the focal point is at point A. Magnification M of the emitting area is given as

$$M = \frac{\pi R_L^2}{\pi r_s^2} = \left(\frac{R_L}{r_s} \right)^2$$

continued

Using eq. 5.4 one can show that, with the lens, the optical power P_L that can be coupled into a full aperture angle 2θ is given by

$$P_L = P_s \left(\frac{R_L}{r_s} \right)^2 \sin^2 \theta$$

For the fiber of radius a and numerical aperture NA, the maximum coupling efficiency η_{\max} is given by

$$\eta_{\max} = \begin{cases} \left(\frac{a}{r_s} \right)^2 (NA)^2 & \text{for } \frac{r_s}{a} > NA \\ 1 & \text{for } \frac{r_s}{a} \leq NA \end{cases}$$

So when the radius of the emitting area is larger than the fiber radius, there'll be no improvement in the coupling efficiency with the use of lens

Laser diode to Fiber Coupling

- Edge emitting laser diodes have an emission pattern that nominally has FWHM of
 - **30 – 50° in the plane perpendicular to the active area junction**
 - **5 – 10° in the plane parallel to the junction**
- As the angular output distribution of the laser is greater than the fiber acceptance angle and since the laser emitting area is much smaller than the fiber core, so that one can use
 - **spherical lenses**
 - **cylindrical lenses**
 - **Fiber taper**to improve the coupling efficiency between edge emitting laser diodes and optical fibers
- Same technique is used for vertical cavity surface emitting lasers (VCSELs).

continued

- Mass produced connections of laser arrays to parallel multimode fiber has efficiencies of 35%
- Direct (lensless) coupling from a single VCSEL source to a multimode fiber results into efficiencies of upto 90%.
- The use of homogeneous glass microsphere lenses has been tested in series of several hundred laser diode assemblies.
- Spherical glass lens of refractive index 1.9 and diameters ranging between 50 and 60 μm were epoxied to the ends of 50 μm core diameter graded index fibers having NA of 0.2. The measured FWHM values of the laser output beams were as follows
 - ***b/w 3 and 9 μm for the near field parallel to the junction***
 - ***b/w 30 and 60° for the field perpendicular to the junction***
 - ***b/w 15 and 55° for the field parallel to the junction***

Coupling efficiencies in these experiments ranged between 50 and 80%.

Fiber-to-Fiber Joints

Interconnecting fibers in a fiber optic system is another very important factor. These interconnects should be low-loss. These interconnects occur at

- **Optical source**
- **Photodetector**
- **Within the cable where two fibers are connected**
- **Intermediate point in a link where two cables are connected**

The connection can be

- **Permanent bond:** **known as *SPLICE***
- **Easily demountable connection:** **Known as *CONNECTOR***

continued

- All joining techniques are subject to different levels of power loss at the joint. These losses depend on different parameters like
 - **Input power distribution to the joint**
 - **Length of the fiber between the source and the joint**
 - **Geometrical and waveguide characteristics of the two ends at the joint**
 - **Fiber end face qualities**
- The optical power that can be coupled from one fiber to the other is limited by the number of modes that can propagate in each fiber
- A fiber with 500 modes capacity connected with the fiber of 400 modes capacity can only couple 80% of the power
- For a GIN fiber with core radius a , cladding index n_2 , $k=2\pi/\lambda$, and $n(r)$ as the variation in the core index profile, the total number of modes can be found from the expression

$$M = k^2 \int_0^a [n^2(r) - n_2^2] r dr \quad 5.18$$

continued

- Eq. 5.18 can be associated with the general local numerical aperture to yield

$$\begin{aligned} M &= k^2 \int_0^a \text{NA}^2(r) r dr \\ &= k^2 \text{NA}^2(0) \int_0^a \left[1 - \left(\frac{r}{a} \right)^\alpha \right] r dr \end{aligned}$$

- As the different fibers can have different values of a , $\text{NA}(0)$ and α , so M can be different for different fibers
- The fraction of energy that can be coupled is proportional to the common mode volume M_{comm} . The fiber-to-fiber coupling efficiency η_F is given by

$$\eta_F = \frac{M_{\text{comm}}}{M_E}$$

Where M_E is the number of modes in the emitting fiber. The fiber-to-fiber coupling loss L_F is given in terms of η_F as

$$L_F = -10 \log y_F$$

Case a: All modes equally excited, joint with fiber of the same size having even slight mechanical misalignment can cause power loss

Case b: Propagating modes in the steady state have an equilibrium NA. Joining with an optical fiber of the same core size and same characteristics will face a NA of larger size in the receiving fiber and even a mechanical misalignment cannot cause the power loss.

case b is for longer fibers. Power loss will occur when in the receiving fiber, steady state will be achieved

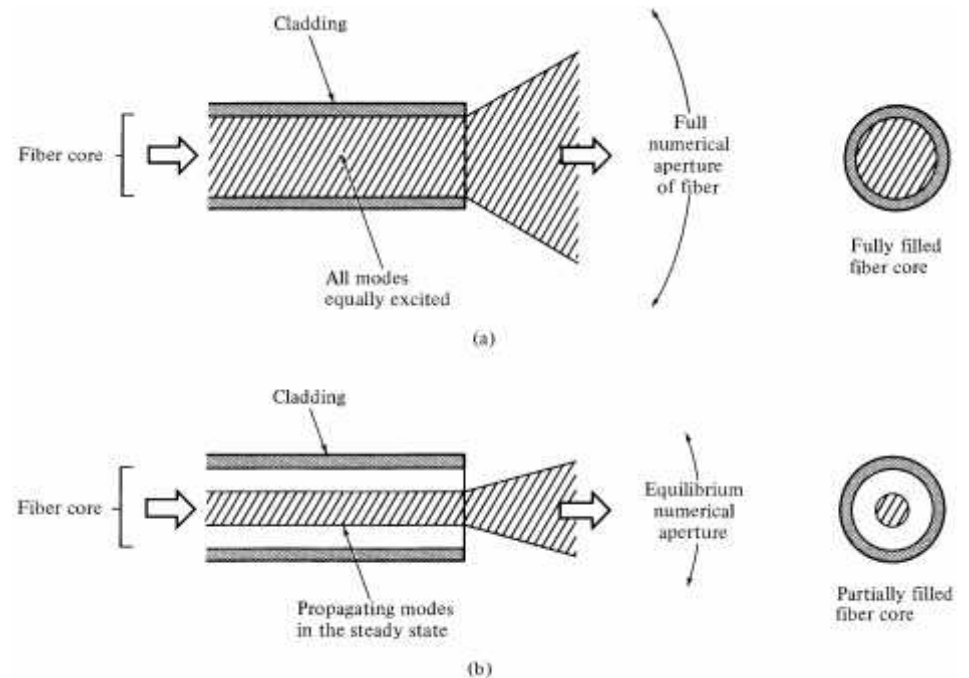

Mechanical Misalignment

- Mechanical alignment is the major problem when joining two fibers considering their microscopic size.
- A standard multimode GIN fiber core is 50 - 100 μm in diameter (thickness of the human hair)
- Single mode fiber has core dia of 9 μm
- Radiation losses occur because the acceptance cone of the emitting fiber is not equal to the acceptance cone of the receiving fiber.
- Magnitude of radiation loss depends on the degree of misalignment
- Three different types of misalignment can occur
 - Longitudinal Separation
 - Angular misalignment
 - Axial displacement or lateral displacement

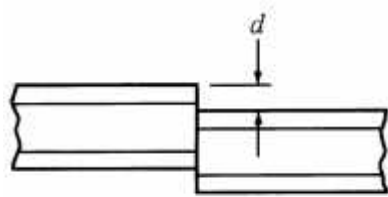

(a) Lateral (axial)

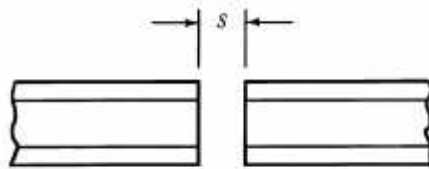

(b) Longitudinal (end separation)

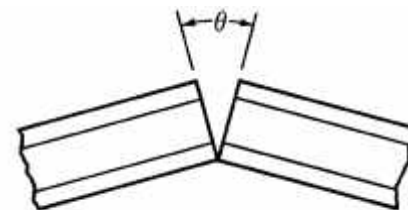

(c) Angular

Axial displacement

- Most common misalignment is the axial displacement.
- It causes the greatest power loss

Illustration:

- Axial offset reduces the overlap area of the two fiber-core end faces
- This in turn reduces the power coupled between two fibers.

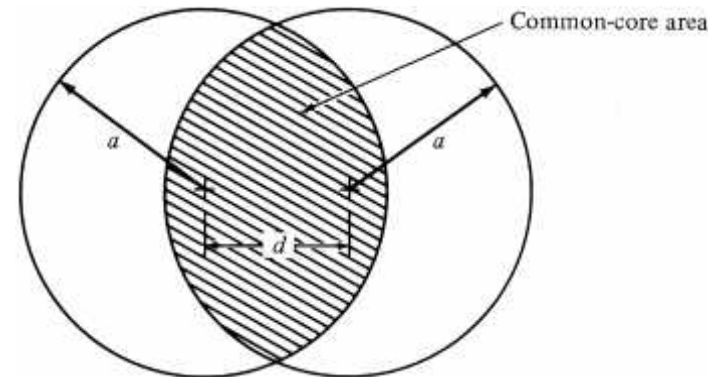

continued

- To illustrate the effect of misalignment, consider two identical step-index fibers of radii a .
- Suppose the axes are offset by a separation d
- Assume there is a uniform modal power distribution in the emitting fiber.
- NA is constant for the two fibers so coupled fiber will be proportional to the common area A_{comm} of the two fiber cores
- **Assignment: show that A_{comm} has expression**

$$A_{\text{comm}} = 2a^2 \arccos \frac{d}{2a} - d \left(a^2 - \frac{d^2}{4} \right)^{1/2}$$

- For step index fiber, the coupling efficiency is simply the ratio of the common core area of the core end face area

$$\eta_{F, \text{step}} = \frac{A_{\text{comm}}}{\pi a^2} = \frac{2}{\pi} \arccos \frac{d}{2a} - \frac{d}{\pi a} \left[1 - \left(\frac{d}{2a} \right)^2 \right]^{1/2}$$

continued

- For **Graded Index Fiber** the calculations for the power loss between two identical fibers is more complex since n varies across the end face of the core.
- The total power coupled in the common area is restricted by the NA of the transmitting or receiving fiber at the point, depending which one is smaller.
- If the end face of the GIN fiber is uniformly illuminated, the optical power accepted by the core will be that power which falls within the NA of the fiber.
- The optical power density $p(r)$ at a point r on the fiber end is proportional to the square of the local $NA(r)$ at that point

$$p(r) = p(0) \frac{NA^2(r)}{NA^2(0)}$$

Where $NA(r)$ and $NA(0)$ are defined by eqs. 2.80. $p(0)$ is the power density at the core axis which is related to the total power P in the fiber by

$$P = \int_0^{2\pi} \int_0^a p(r) r dr d\theta$$

We can use the parabolic index profile ($\alpha = 2.0$) for which $p(r)$ will be given as

$$p(r) = p(0)[1 - \{r/a\}^2]$$

P will be calculated as

$$P = \left(\frac{a^2}{2} \right) p(0)$$

The calculations of received power for GIN fiber can be carried out and the result will be

$$P_T \approx P \left(1 - \frac{8d}{3\pi a} \right)$$

Where P is the total power in the transmitting fiber, d is the distance between two axes and a is the radius of fiber

continued

The coupling loss for the offsets is given as

$$L_F = -10 \log \eta_F = -10 \log \frac{P_T}{P}$$

For Longitudinal misalignment:

For longitudinal misalignment of distance s , the coupling loss is given as

$$L_F = -10 \log \left(\frac{a}{a + s \tan \theta_c} \right)^2$$

Where s is the misalignment and θ_c is the critical acceptance angle of the fiber

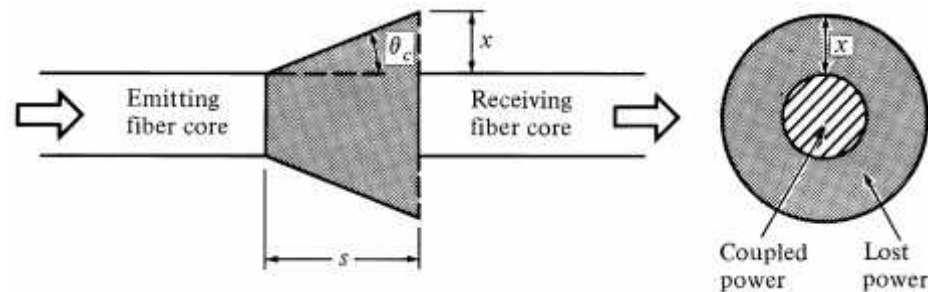

Angular misalignment at the joint

When the axes of two fibers are angularly misaligned at the joint, the optical power that leaves the emitting fiber outside the acceptance angle of the receiving fiber will be lost. For two step index fibers with misalignment angle θ , the optical power loss at the joint will be

$$L_F = -10 \log \left(\cos \theta \left\{ \frac{1}{2} - \frac{1}{\pi} p (1 - p^2)^{1/2} - \frac{1}{\pi} \arcsin p \right. \right. \\ \left. \left. - q \left[\frac{1}{\pi} y (1 - y^2)^{1/2} + \frac{1}{\pi} \arcsin y + \frac{1}{2} \right] \right\} \right)$$

where

$$p = \frac{\cos \theta_c (1 - \cos \theta)}{\sin \theta_c \sin \theta}$$

$$q = \frac{\cos^3 \theta_c}{(\cos^2 \theta_c - \sin^2 \theta)^{3/2}}$$

$$y = \frac{\cos^2 \theta_c (1 - \cos \theta) - \sin^2 \theta}{\sin \theta_c \cos \theta_c \sin \theta}$$

Fiber Related Losses

Fiber losses are related to the

- Core diameter
- Core area ellipticity, numerical aperture
- Refractive index profiles
- Core-cladding concentricity

Fiber losses are significant for differences in core radii and NA

Different core radii: Loss is given as

$$L_F(a) = \begin{cases} -10 \log \left(\frac{a_R}{a_E} \right)^2 & \text{for } a_R < a_E \\ 0 & \text{for } a_R \geq a_E \end{cases}$$

Different NA: Power loss is given as

$$L_F(NA) = \begin{cases} -10 \log \left[\frac{NA_R(0)}{NA_E(0)} \right]^2 & \text{for } NA_R(0) < NA_E(0) \\ 0 & \text{for } NA_R(0) \geq NA_E(0) \end{cases}$$

Different core index profiles: Coupling loss will be given as

$$L_F(\alpha) = \begin{cases} -10 \log \frac{\alpha_R(\alpha_E + 2)}{\alpha_E(\alpha_R + 2)} & \text{for } \alpha_R < \alpha_E \\ 0 & \text{for } \alpha_R \geq \alpha_E \end{cases}$$

Fiber End Face Preparation

- End face preparation is the first step before splicing or connecting the fibers through connectors.
- Fiber end must be
 - Flat
 - Perpendicular to the fiber axis
 - Smooth
- Techniques used are
 - Sawing
 - Grinding
 - Polishing
- Grinding and Polishing require a controlled environment like laboratory or factory

continued

- Controlled fracture techniques are used to cleave the fiber

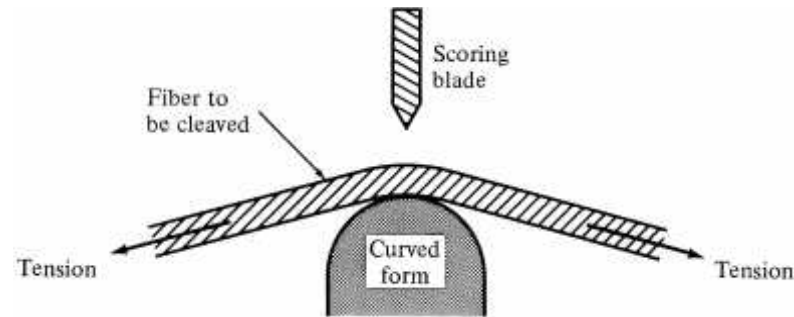

- Highly smooth and perpendicular end faces can be produced through this method
- Requires a careful control of the curvature and the tension
- Improperly controlled tension can cause multiple fracture and can leave a lip or hackled portion

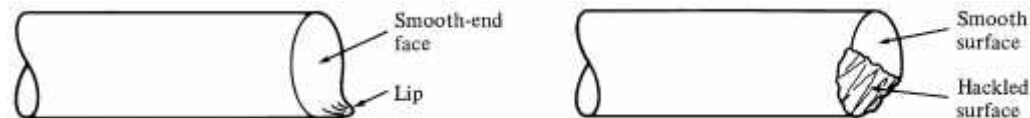

Fiber Splicing

Three different types of splicing can be done

- ***Fusion splicing***
- ***V-groove mechanical splicing***
- ***Elastic tube splice***

Influences on Fusion Process

Self-Centering Effect

The self-centering effect is the tendency of the fiber to form a homogeneous joint which is consequently free of misalignment as a result of the surface tension of the molten glass during the fusion bonding process

Core Eccentricity

The process of aligning the fiber cores is of great importance in splicing. Fibers with high core eccentricity can cause, depending on the position of the relating cores, increased splice losses due to the core offset within the splice

Fiber End Face Quality

The end face quality of fibers to be fused directly influences the splice loss. Thus when cleaving fibers for splicing, the end face of the fiber has to be clean, unchipped, flat and perpendicular to the fiber axis

Influences on Fusion Process

Fiber Preparation Quality

When preparing the fibers for splicing, it is necessary to ensure that no damage occurs to the fiber cladding

Any damage to the unprotected glass of the fiber can produce micro cracks causing the fiber to break during handling, splicing or storage

Dirt Particles or Coating Residues

Any contamination on the fiber cladding or in the v-grooves can lead to bad fiber positioning.

This can cause fiber offset (fiber axis misalignment) and can influence the fusion process extremely like bad cleave angles

Influences on Fusion Process

Fiber Melting Characteristics

When fibers are brought together for splice some air gaps are present, called gas bubbles

Electric arc should not be too intense or weak.

When electric arc melts the fibers, the glass tends to collapse inwards, filling the gap

Electrode Condition

High quality splices require a reproducible and stable fusion arc.

Fusion arc is influenced by electrode condition.

Electrode cleaning or replacement is necessary from time to time.

Fusion Splicing

- It is the thermal bonding of two prepared fiber ends

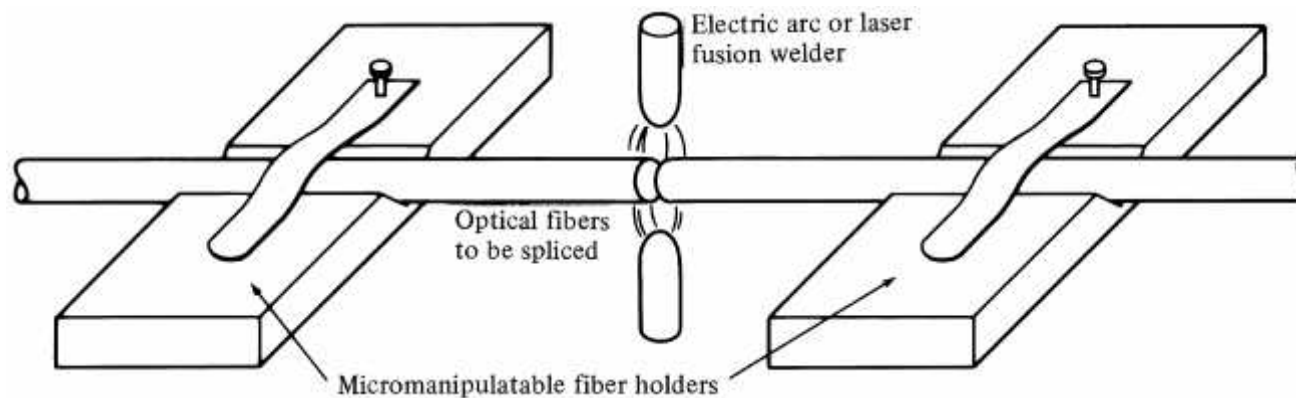

- The chemical changes during melting sometimes produce a weak splice
- Produce very low splice losses

V-groove splicing

- The prepared fiber ends are first butt together in a V-shaped groove
- They are bonded with an adhesive
- The V-shaped channel is either grooved silicon, plastic ceramic or metal substrate
- Splice loss depends on the fiber size and eccentricity

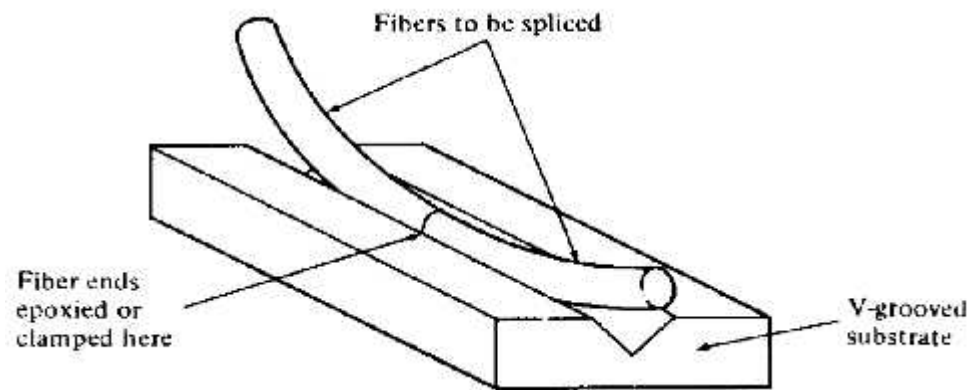

Elastic Tube splicing

- It automatically performs lateral, longitudinal and angular alignment
- It splices multimode fiber with losses in the range as commercial fusion splice
- Less equipment and skills are needed
- It consists of tube of an elastic material
- Internal hole is of smaller diameter as compared to the fiber and is tapered at two ends for easy insertion of the fiber
- A wide range of fiber diameters can be spliced
- The fibers to be spliced might not be of the same diameter, still its axial alignment will be maximum

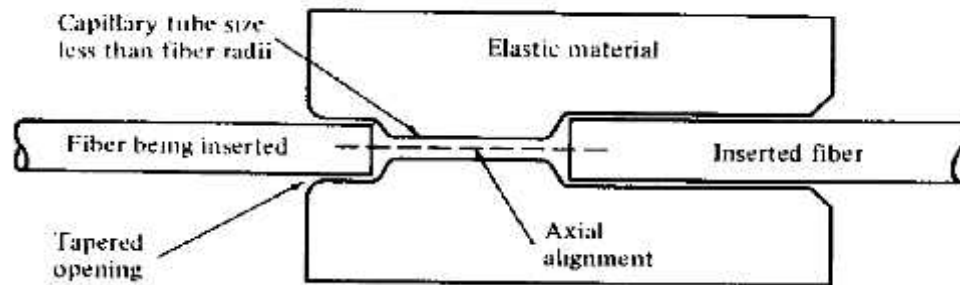

Optical Fiber Connectors

Principle requirements of a good connector design are as follows:

Coupling loss:

The connector assembly must maintain stringent alignment tolerances to ensure low mating losses. The losses should be around 2 to 5 percent (0.1 to 0.2 dB) and must not change significantly during operation and after numerous connects and disconnects.

Interchangeability:

Connectors of the same type must be compatible from one manufacturer to another.

Ease of assembly:

A service technician should be able to install the connector in a field environment, that is, in a location other than the connector attachment factory.

Low environmental sensitivity:

Conditions such as temperature, dust, and moisture should have a small effect on connector loss variations.

Low cost and reliable construction:

The connector must have a precision suitable to the application, but it must be reliable and its cost must not be a major factor in the system.

Ease of connection:

Except for certain unique applications, one should be able to mate and disconnect the connector simply and by hand.

Connector components

Connectors are available in designs that **screw on**, **twist on**, or **snap in** place. The **twist-on and snap-on** designs are the ones used most commonly.

The basic coupling mechanisms used belong to either **butt-joint** or the **expanded-beam classes**. The majority of connectors use a butt-joint coupling mechanism.

Butt-joint connector:

The key components are a long, thin stainless steel, glass, ceramic, or plastic cylinder, known as a **ferrule**, and a **precision sleeve** into which the ferrule fits.

This sleeve is known variably as an alignment sleeve, an adapter, or a coupling receptacle.

The center of the ferrule has a hole that precisely matches the size of the fiber cladding diameter.

Connector components

Expanded beam connector :

Employs lenses on the end of the fiber.

These lenses either collimate the light emerging from the transmitting fiber, or focus the expanded beam onto the core of the receiving fiber.

Optical processing elements, such as beam splitters and switches, can easily be inserted into the expanded beam between the fiber ends.

Connector types

- Connector are available in designs that **screw on**, **twist on**, or **snap into place**
- Most commonly used are **twist on**, or **snap on** designs
- These include single channel and multi channel assemblies
- The basic coupling mechanism is either a Butt joint or an expanded beam class
- Butt joint connectors employ a metal, ceramic or a molded plastic Ferrule for each fiber

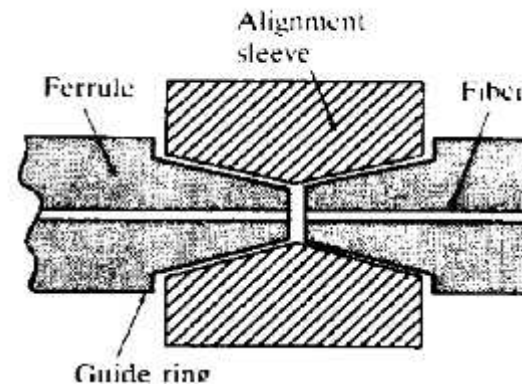
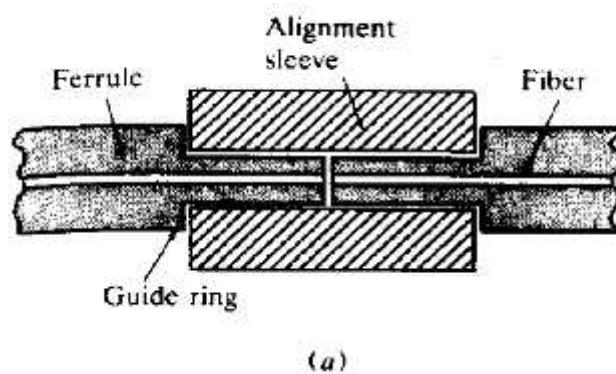

Expanded Beam Fiber Optic connector

- Expanded beam connector employs lenses on the end of the fibers.
- The lenses collimate the light emerging from the transmitting fiber and focuses the beam on the receiving fiber
- The fiber to lens distance is equal to the focal length
- As the beam is collimated so even a separation between the fibers will not make a difference
- Connector is less dependent on the lateral alignment
- Beam splitters or switches can be inserted between the fibers

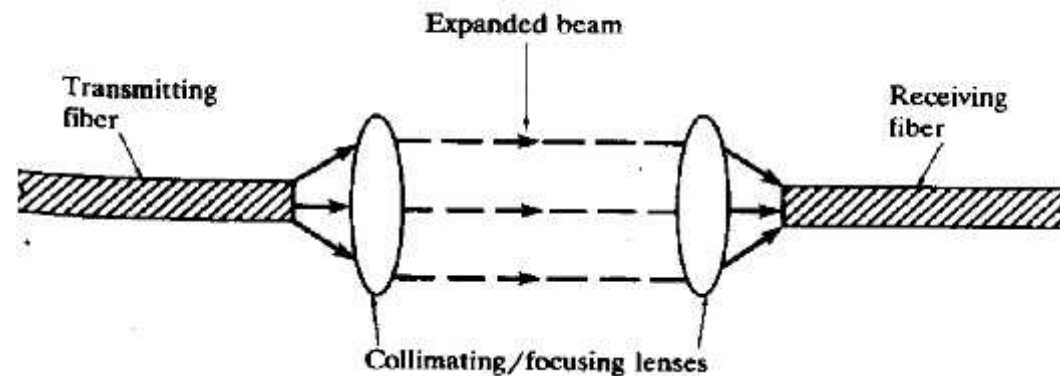

Optical Connector Types

There are numerous connector styles and configurations.

The main ones are ST, SC, FC, LC, MU, MT-RJ, MPO, and variations on MPO.

- ST** ST is derived from the words **straight tip**, which refers to the ferrule configuration.
- SC** SC mean **subscriber connector or square connector**, although now the connectors are not known by those names.
- FC** A connector designed specifically for **Fibre Channel** applications was designated by the letters FC.
- LC** Since **Lucent** developed a specific connector type, they obviously nicknamed it the LC connector.
- MU** The letters MU were selected to indicate a **miniature unit**.

Optical Connector Types

MT-RJ The designation MT-RJ is an acronym for **media termination—recommended jack**.

MPO The letters MPO were selected to indicate a **multiple-fiber, push-on/pull-off** connecting function.



ST connector

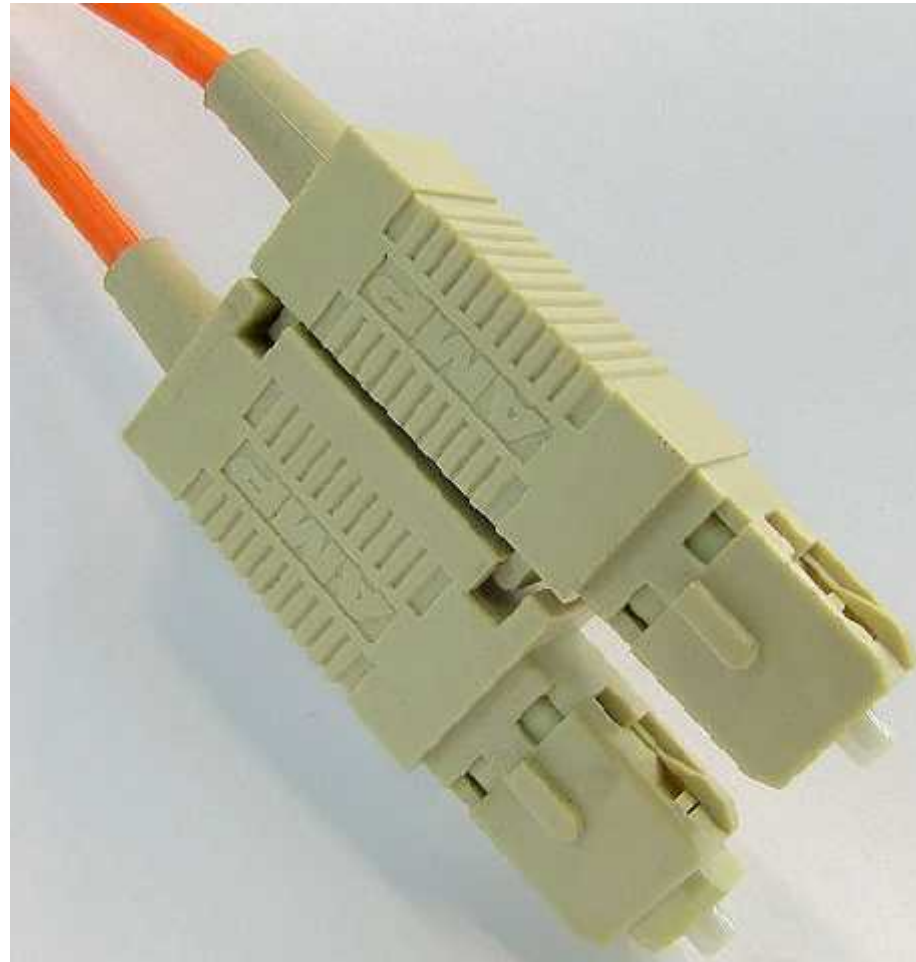

SC connector



FC connector



LC connector



MU



MT-RJ



MPO

Summary

Coupling efficiency

Flylead / Pigtail

Optical fiber receptacles

Source to fiber power launching

Power coupling calculations

Lensing Scheme for Coupling Improvement

Fiber Splicing

Splicing techniques

Good Splice Requirements

Splice Preparation

Influences on Fusion Process

Fusion Splicing Methods

Optical Fiber Connectors

Connector components

Optical Connector Types

Coupling Losses

Intrinsic losses

Extrinsic losses

QUIZ

Using equation
$$P = \int_0^{r_m} \int_0^{2\pi} \left[\int_0^{2\pi} \int_0^{\theta_{\max}} B(\theta, \phi) \sin \theta \, d\theta \, d\phi \right] d\theta \, r \, dr$$

derive an expression for the power coupled into a step-index fiber from an LED that has a radiant distribution given by

$$B(\theta) = B_0 \cos^m \theta$$