



# **PC MAINTENANCE**

## **3RD CLASS**

### **LECTURE 1**

**AL FURAT AL AWSAT  
TECHNICAL UNIVERSITY**

**NAJAF COLLEGE OF  
TECHNOLOGY**

**DEPARTMENT OF TECHNICAL  
COMMUNICATIONS  
ENGINEERING**

**Academic Responsible**

**HAYDER S. RASHID**

**2016/2017**

## Introduction to the PC system

A computer system consists of hardware and software components. Hardware is the physical equipment such as the case, storage drives, keyboards, monitors, cables, speakers, and printers. While software is represented by the operating system and the programs. Firstly, let's start with the physical equipment.

### 1- What's Inside a Desktop Case

Before we discuss the parts inside a desktop case, let's take a quick look at the case and the ports and switches on it. A computer case for any type of computer is sometimes called the **chassis** and houses the power supply, motherboard, processor, memory modules, expansion cards, hard drive, optical drive, and other drives. A computer case can be a tower case, a desktop case that lies flat on a desk, an all-in-one case used with an all-in-one computer, or a mobile case used with laptops and tablets. A **tower case** (see Figure 1) sits upright and can be as high as two feet and has room for several drives. Often used for servers, this type of case is also good for desktop computer users who anticipate upgrading, because tower cases provide maximum space for working inside a computer and moving components around. A **desktop case** lies flat and sometimes serves double-duty as a monitor stand.



**Notes** Don't lay a tower case on its side when the computer is in use because the CD or DVD drive might not work properly. For the same reason, if a desktop case is designed to lie flat, don't set it on its end when the computer is in use.

Figure (1) This slimline tower case supports a micro ATX motherboard

Table (1) lists ports you might find on a desktop or mobile computer. Consider this table your introduction to these ports so that you can recognize them when you see them.

Port	Description
	A <b>VGA (Video Graphics Array) port</b> , also called a <b>DB-15 port</b> , <b>DB15 port</b> , <b>HD15 port</b> , or <b>DE15 port</b> , is a 15-pin, D-shaped, female port that transmits analog video. ( <b>Analog</b> means a continuous signal with infinite variations as compared with <b>digital</b> , which is a series of binary values—1s and 0s.) All older monitors use VGA ports. (By the way, the HD15 [high-definition 15-pin] name for the port is an older name that distinguishes it from the early 9-pin VGA ports.)
	An <b>S-Video port</b> is a 4-pin or 7-pin round video port sometimes used to connect to a television. The 7-pin port is shown on the left. The 4-pin port is missing the extra pins in the middle and is the more common type.
Port	Description
	A <b>DVI (Digital Video Interface) port</b> transmits digital or analog video. Three types of DVI ports exist, which you learn about in the chapter, "Supporting I/O Devices."
	An <b>HDMI (High-Definition Multimedia Interface) port</b> transmits digital video and audio (not analog transmissions) and is often used to connect to home theater equipment.
	A <b>DisplayPort</b> transmits digital video and audio (not analog transmissions) and is slowly replacing VGA and DVI ports on personal computers.
 <small>Courtesy of Creative Commons Attribution 3.0, Macfan87</small>	A <b>Thunderbolt port</b> transmits video, data, and power on the same port and cable and is popular with Apple computers. The port is shaped the same as the DisplayPort and is compatible with DisplayPort devices. Up to six peripherals (for example, monitors and external hard drives daisy-chained together) can use the same Thunderbolt port.
	A <b>network port</b> , also called an <b>Ethernet port</b> , or an <b>RJ-45 port</b> , is used by a network cable to connect to the wired network. Fast Ethernet ports run at 100 Mbps (megabits per second), and Gigabit Ethernet runs at 1000 Mbps or 1 Gbps (gigabits per second). A megabit is one million bits and a gigabit is one billion bits. A bit is a binary value of 1 or 0.

Table (1) Ports used with desktop and mobile computers (continues)

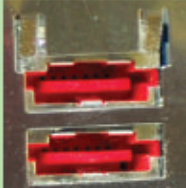



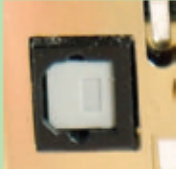
Port	Description
	<p>An <b>external SATA (eSATA) port</b> is used by an external hard drive or other device using the eSATA interface. eSATA is faster than FireWire.</p>
	<p>A <b>PS/2 port</b>, also called a mini-DIN port, is a round 6-pin port used by a keyboard or mouse. The ports look alike but are not interchangeable. On a desktop, the purple port is for the keyboard, and the green port is for the mouse. Many newer computers use USB ports for the keyboard and mouse rather than the older PS/2 ports.</p>
	<p>An older <b>serial port</b>, sometimes called a <b>DB9 port</b>, is a 9-pin male port used on older computers. It has been mostly replaced by USB ports. Occasionally, you see a serial port on a router where the port is used to connect the router to a device a technician can use to monitor and manage the router.</p>
	<p>A <b>parallel port</b>, also called an <b>LPT port</b>, is a 25-pin female port used by older printers. This older port has been replaced by USB ports.</p>
	<p>A <b>modem port</b>, also called an <b>RJ-11 port</b>, is used to connect dial-up phone lines to computers. A modem port looks like a network port, but is not as wide. In the photo, the right port is a modem port and the left port is a network port, shown for comparison.</p>
	<p>A system usually has three or more round <b>audio ports</b>, also called sound ports, for a microphone, audio in, audio out, and stereo audio out. These types of audio ports can transmit analog or digital data. If you have one audio cable to connect to a speaker or earbuds, plug it into the lime green sound port in the middle of the three ports. The microphone uses the pink port.</p>
	<p>An <b>S/PDIF (Sony/Philips Digital Interface) sound port</b> connects to an external home theater audio system, providing digital audio output and the best signal quality. S/PDIF ports always carry digital audio and can work with electrical or optical cable. When connected to a fiber-optic cable, the port is called an <b>optical connector</b>.</p>
	<p>A <b>USB (Universal Serial Bus) port</b> is a multipurpose I/O port that comes in several sizes and is used by many different devices, including printers, mice, keyboards, scanners, external hard drives, and flash drives. Some USB ports are faster than others. Hi-Speed USB 2.0 is faster than regular USB, and Super-Speed USB 3.0 is faster than USB 2.0.</p>
	<p>A <b>FireWire port</b> (also called an <b>IEEE 1394 port</b>, pronounced "I-triple-E 1394 port") is used for high-speed multimedia devices such as digital camcorders.</p>

Table (1) Ports used with desktop and mobile computers (continued)

Firstly, let's get familiar with the major components in the case and how to work with them safely so you don't fry a motherboard or bend delicate connectors. Figure (2) shows the inside of a computer case.

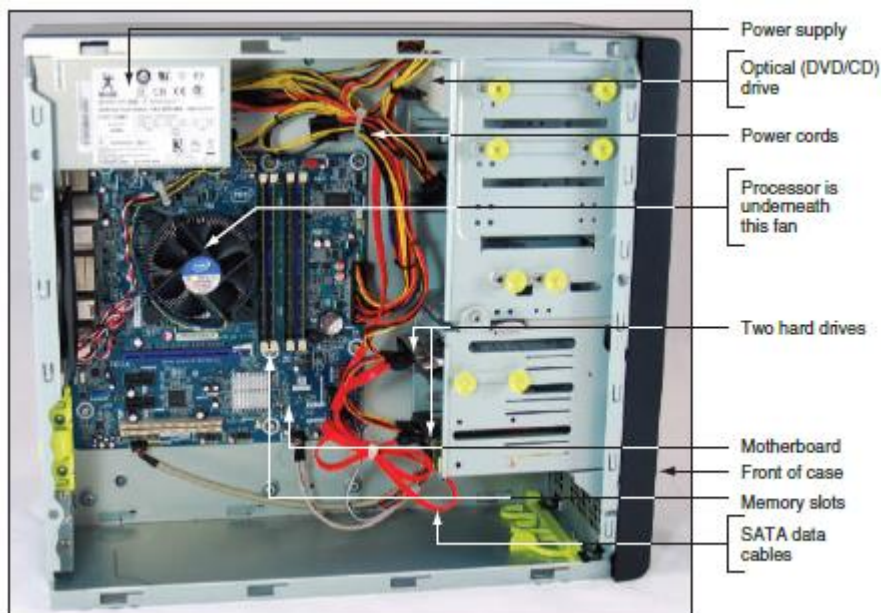


Figure (2) Inside the computer case

Here is a quick explanation of the main components installed in the case, which are called **internal components**:

**1.1- The motherboard, processor, and cooler.** The **motherboard**, also called the **main board**, or the **system board**, is the largest and most important circuit board in the computer. The motherboard contains a socket to hold the processor or CPU. The **central processing unit (CPU)**, also called the **processor** or **microprocessor**, does most of the processing of data and instructions for the entire system. Because the CPU generates heat, a fan and heat sink might be installed on top to keep it cool. A **heat sink** consists of metal fins that draw heat away from a component. The fan and heat sink together are called the processor cooler. Figure (3) shows the top view of a motherboard, and Figure (4) shows the ports on the side of a motherboard.

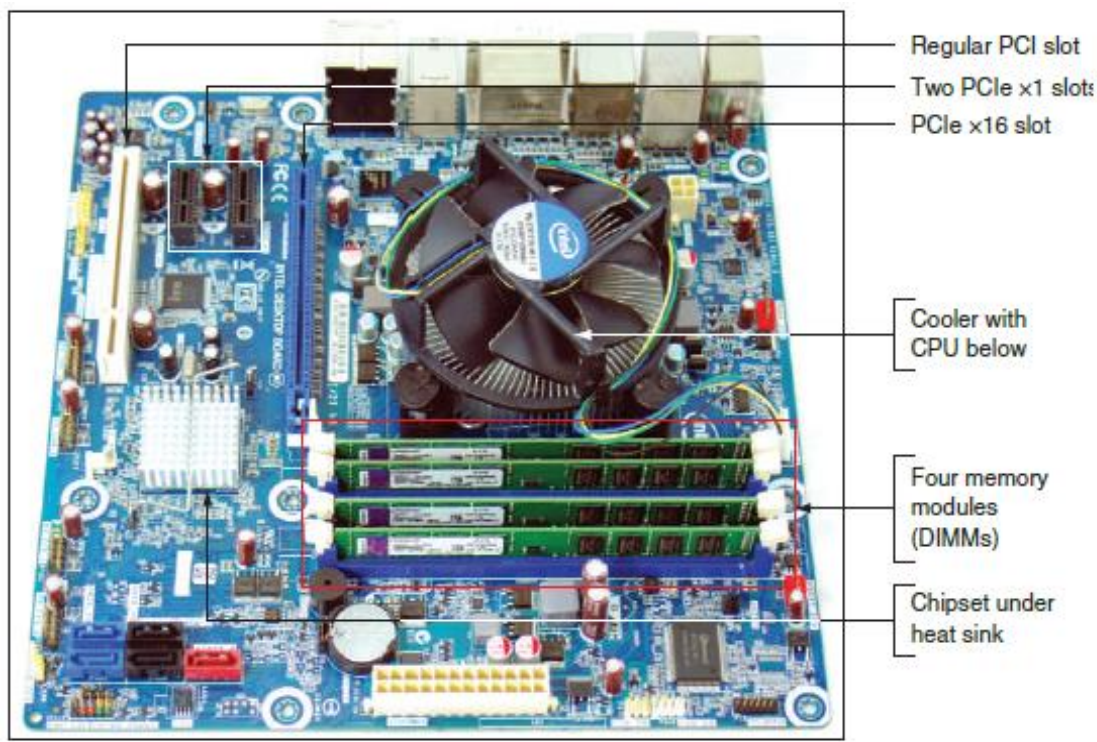


Figure (3) All hardware components are either located on the motherboard or directly or indirectly connected to it because they must all communicate with the CPU

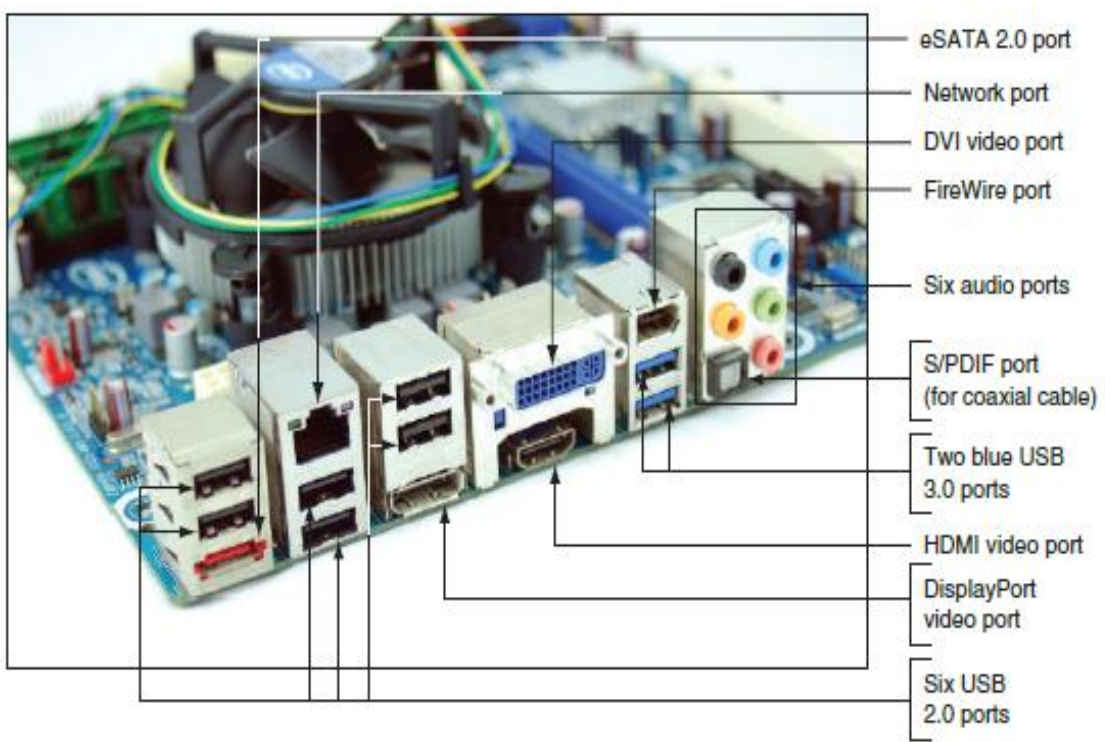


Figure (4) Ports provided by a motherboard

**1.2- Expansion cards.** A motherboard has expansion slots to be used by expansion cards. An **expansion card**, also called an adapter card, is a circuit board that provides more ports than those provided by the motherboard. Figure (5) shows a video card that provides three video ports. Notice the cooling fan and heat sink on the card, which help to keep the card from overheating. The trend today is for most ports in a system to be provided by the motherboard (called onboard ports) and less use of expansion cards.

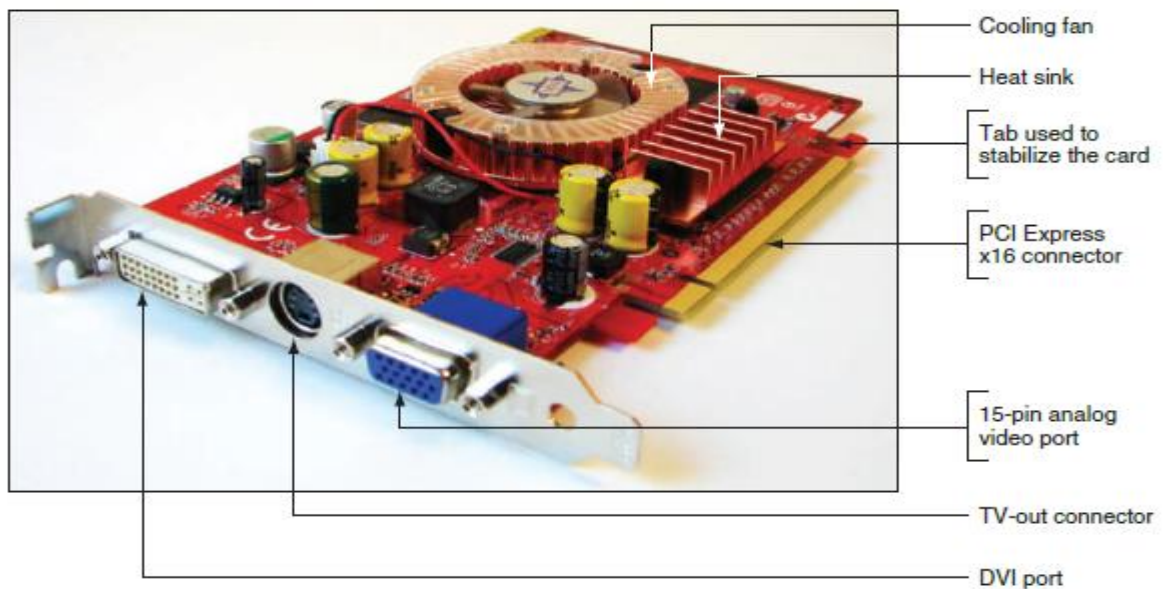


Figure (5) The easiest way to identify this video card is to look at the ports on the end of the card

**1.3- Memory modules.** A desktop motherboard has memory slots, called **DIMM (dual inline memory module)** slots, to hold memory modules. Figure (6) shows a memory module installed in one DIMM slot and three empty DIMM slots. Memory, also called **RAM (random access memory)**,



Figure (6) A DIMM holds RAM and is mounted directly on a motherboard

is temporary storage for data and instructions as they are being processed by the CPU.

The memory module shown in Figure (6) contains several RAM chips. Video cards also contain some embedded RAM chips for **video memory**.

**1.4- Hard drives and other drives.** A system might have one or more hard drives, an optical drive, a tape drive, or, for really old systems, a floppy drive. A **hard drive**, also called a **hard disk drive (HDD)**, is permanent storage used to hold data and programs. For example, the Windows 8 operating system and applications are installed on the hard drive. All drives in a system are installed in a stack of drive bays at the front of the case. The system shown in Figure (2) has two hard drives and one optical drive installed. These three drives are also shown in Figure (7). The larger hard drive is a magnetic drive, and the smaller hard drive is a solid-state drive. Each drive has two connections for cables: The power cable connects to the power supply, and another cable, used for data and instructions, connects to the motherboard.



Figure (7) Two types of hard drives (larger magnetic drive and smaller solid-state drive) and a DVD drive

**1.5- A power supply.** A computer power supply, also known as a power supply unit (PSU), is a box installed in a corner of the computer case (see Figure 8) that receives and converts the house current so that components inside the case can use it. Most power supplies have a dual-voltage selector switch on the back of the computer case where you can switch the input voltage to the power supply to 115 V used in the United States or 220 V used in other countries. See Figure (9). The power cables can connect to and supply power to the motherboard, expansion cards, and drives.

**Notes** If you ever need to change the dual-voltage selector switch, be sure you first turn off the computer and unplug the power supply.





Figure (8) Power supply with attached power cables



Figure (9) The dual-voltage selector switch sets the input voltage to the power supply

## 2- Form Factors

The desktop computer case, power supply, and motherboard must all be compatible and fit together as an interconnecting system. The standards that describe the size, shape, screw hole positions, and major features of these interconnected components are called **form factors**. Using a matching form factor for the motherboard, power supply, and case assures you that:

- The motherboard fits in the case.
- The power supply cords to the motherboard provide the correct voltage, and the connectors match the connections on the board.

- The holes in the motherboard align with the holes in the case for anchoring the board to the case.
- The holes in the case align with ports coming off the motherboard.
- For some form factors, wires for switches and lights on the front of the case match up with connections on the motherboard.
- The holes in the power supply align with holes in the case for anchoring the power supply to the case.

The two form factors used by most desktop and tower computer cases and power supplies are the ATX and microATX form factors. Motherboards use these and other form factors that are compatible with ATX or microATX power supplies and cases. Following are the important details about ATX and microATX.

### 2.1. ATX Form Factor

**ATX (Advanced Technology Extended)** is the most commonly used form factor today. It is an open, non-proprietary industry specification originally developed by Intel in 1995, and has undergone several revisions since then. The original ATX form factor for cases had case fans blowing air into the case, but early revisions to the form factor had fans blowing air out of the case. Blowing air out of the case does a better job of keeping the system cool.

An ATX power supply has a variety of power connectors (see Figure 10). The power connectors are listed in Table (2) and several of them are described next.

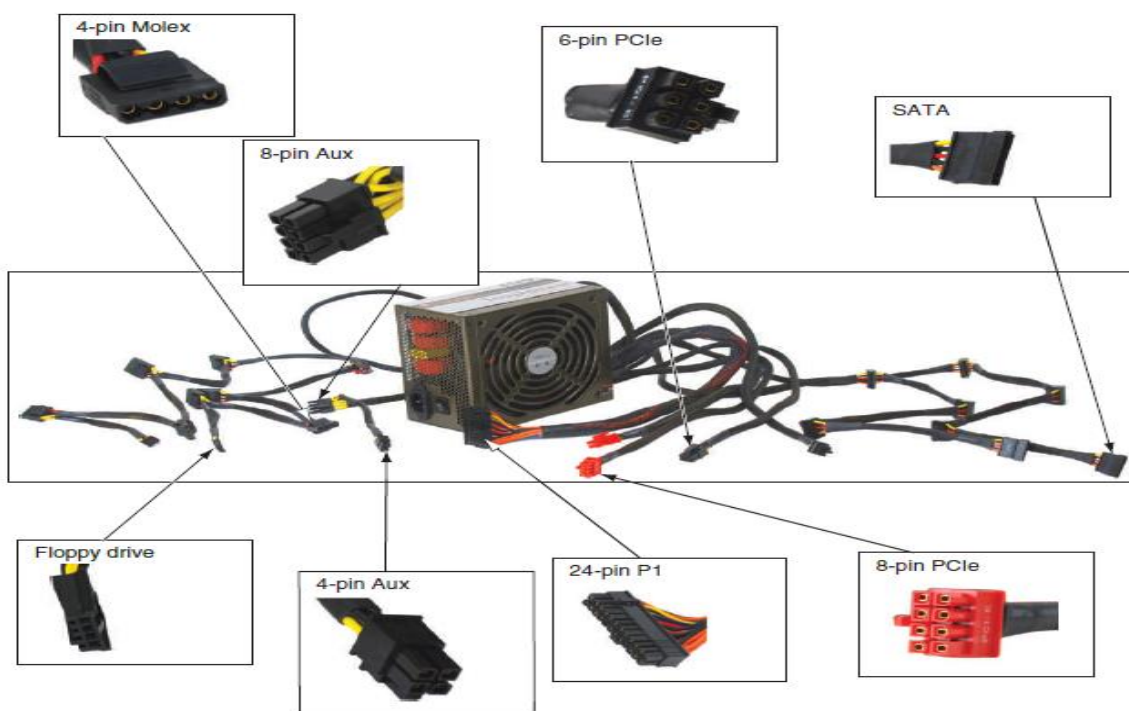


Figure (10) ATX power supply with connectors



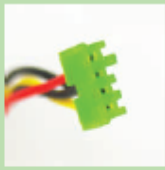



Connector	Description
	The 20-pin P1 connector is the main motherboard power connector used in the early ATX systems.
	The 24-pin P1 connector, also called the 20+4 pin connector, is the main motherboard power connector used today.
	The 4-pin Berg connector is used by older floppy disk drives (FDD).
	The PCIe 6-pin connector provides an extra +12 V for high-end video cards using PCI Express, Version 1 standard.
	The PCIe 8-pin connector provides an extra +12 V for high-end video cards using PCI Express, Version 2.
	The PCIe 6/8-pin connector is used by high-end video cards using PCIe x16 slots to provide extra voltage to the card and can accommodate a 6-hole or 8-hole port. To get the 8-pin connector, combine both the 6-pin and 2-pin connectors.

Table (2) Power supply connectors (continues)

Power connectors have evolved because components using new technologies require more power. As you read about the following types of power connectors and why each came to be, you'll also learn about the evolving expansion slots and expansion cards that drove the need for more power:


Connector	Description
	<p>The 20+4 pin P1 connector has four pins removed so the connector can fit into a 20-pin P1 motherboard connector.</p>
	<p>The 4-pin 12-V connector is an auxiliary motherboard connector, which is used for extra 12-V power to the processor.</p>
	<p>The 8-pin 12-V connector is an auxiliary motherboard connector, which is used for extra 12-V power to the processor, providing more power than the older 4-pin auxiliary connector.</p>
	<p>The 4-pin Molex connector is used for older IDE (PATA or Parallel ATA) drives and some newer SATA drives. It can provide +5 V and +12 V to the drive.</p>
	<p>The 15-pin SATA power connector is used for SATA (Serial ATA) drives. It can provide +3.3V, +5 V, and +12 V, although +3.3 V is seldom used.</p>

Table (2) Power supply connectors (continued)

- **20-pin P1 connector.** The first ATX power supplies and motherboards used a single 20-pin P1 power connector that provided +3.3 volts, +5 volts, +12 volts, -12 volts, and an optional and rarely used -5 volts. See Figure (11). This 20-pin power connector was sufficient for powering expansion cards installed in **PCI (Peripheral Component Interconnect)** expansion slots on the motherboard (see Figure 12).

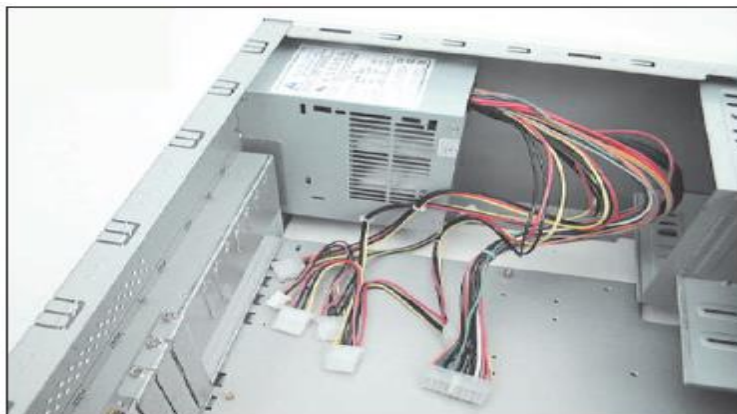


Figure (11) The first ATX P1 power connector used 20 pins

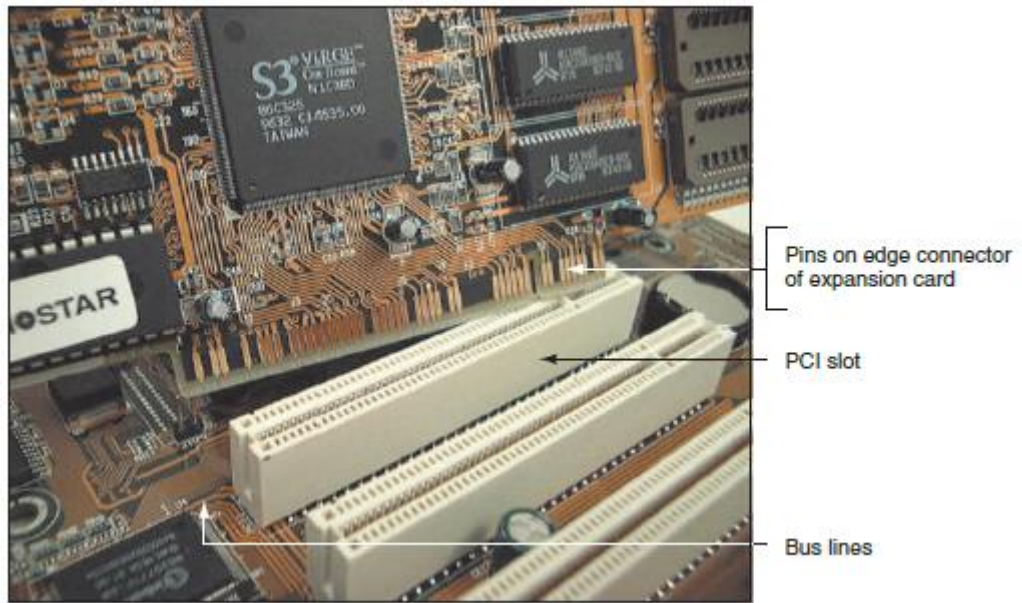


Figure (12) A PCI expansion card about to be installed in a PCI slot

- **4-pin and 8-pin auxiliary connectors.** When processors began to require more power, the ATX Version 2.1 specifications added a 4-pin auxiliary connector near the processor socket to provide an additional 12 V of power (see Figure 13). A power supply that provides this 4-pin 12-volt power cord is called an **ATX12V power supply**. Later boards replaced the 4-pin 12-volt power connector with an 8-pin motherboard auxiliary connector that provided more amps for the processor.

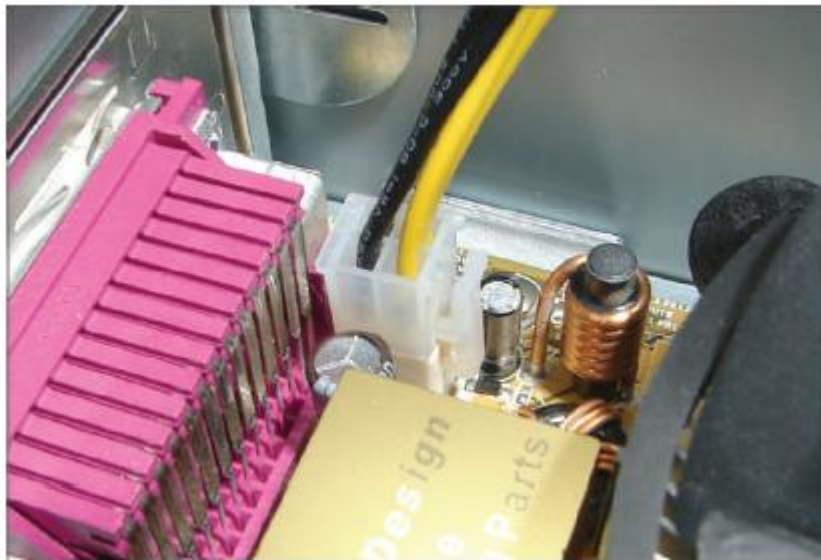


Figure (13) The 4-pin 12-volt auxiliary power connector on a motherboard with power cord connected

- **24-pin or 20+4-pin P1 connector.** Later, when faster PCI Express (PCIe) slots were added to motherboards, more power was required and a new ATX specification (ATX Version 2.2) allowed for a 24-pin P1 connector, also called the 20+4 power connector. The 20-pin power cable will still work in the new 24-pin connector. Looking back at Figure (3), you can see one long blue PCIe ×16 slot (16 lanes for 16-bit transfers on this slot) that can be used by a video card and two short black PCIe ×1 slots (for 1-bit transfers) that can be used for other expansion cards that fit this type slot.

The extra 4 pins on the 24-pin P1 connector provide +12 volts, +5 volts, and +3.3 volts pins. Motherboards that support PCI Express and have the 24-pin P1 connector are sometimes called Enhanced ATX boards. Figure (14) shows a 20-pin P1 power cord from the power supply and a 24-pin P1 connector on a motherboard. Figure (15) shows the pinouts for the 24-pin power cord connector, which is color-coded to wires from the power supply. The 20-pin connector is missing the lower four pins, which are listed in the photo and diagram.

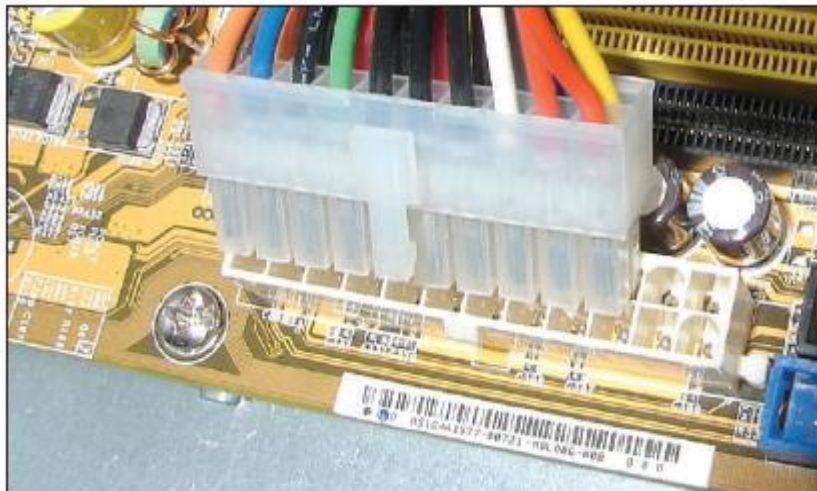


Figure (14) A 20-pin power cord ready to be plugged into a 24-pin P1 connector on an ATX motherboard

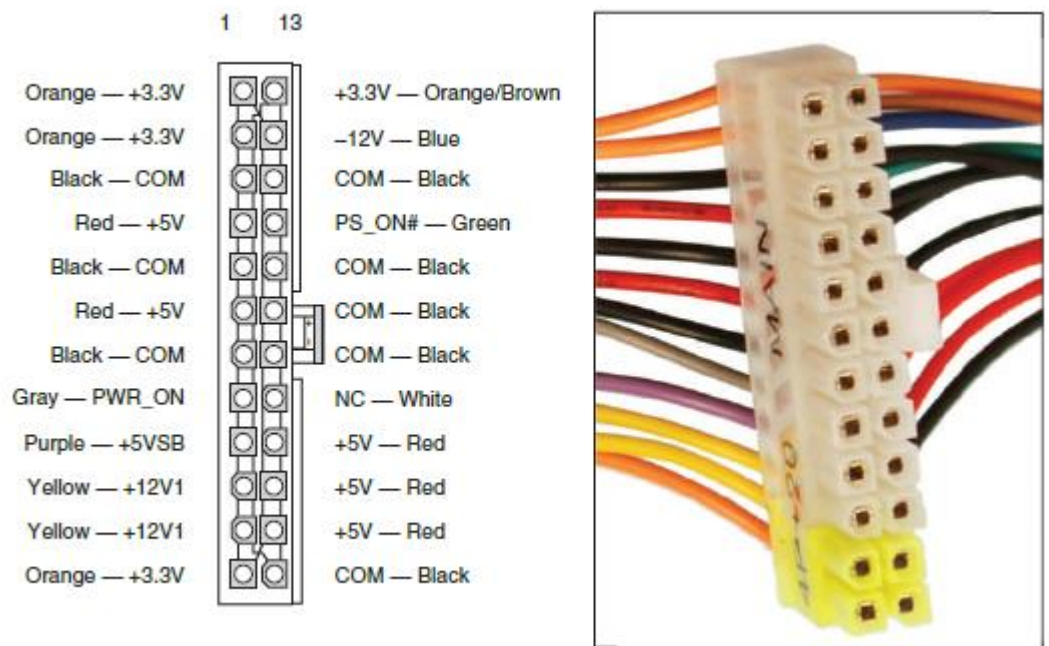


Figure (15) P1 24-pin power connector follows ATX Version 2.2 and higher standards

Figure (16) shows a PCIe ×16 video card. The edge connector has a break that fits the break in the slot. The tab at the end of the edge connector fits into a retention mechanism at the end of the slot, which helps to stabilize a heavy video card.

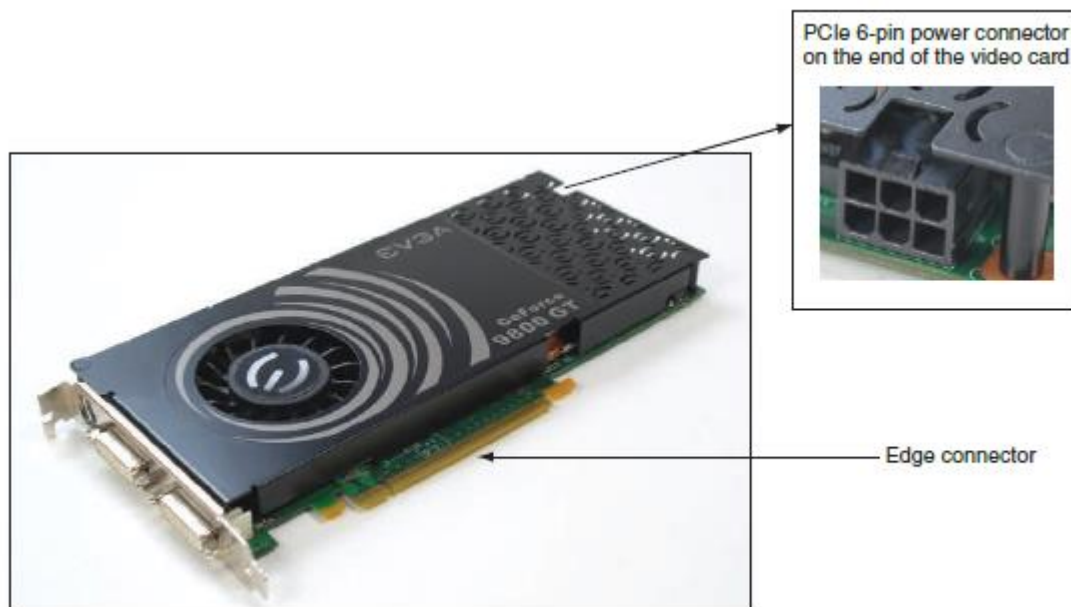


Figure (16) This PCIe ×16 video card has a 6-pin PCIe power connector to receive extra power from the power supply

- **6-pin and 8-pin PCIe connectors.** Video cards draw the most power in a system, and ATX Version 2.2 provides for power cables to connect directly to a video card to provide it additional power than comes through the PCIe slot on the motherboard. The PCIe power connector might have 6 or 8 pins. PCI Express, Version 1, defined the 6-pin connector, and PCI Express, Version 2, defined the 8-pin connector. The video card shown in Figure (16) has a 6-pin connector on the end of the card. A PCIe 6/8-pin connector can also be located on the motherboard to supply extra power for the video card.

## 2.2. Micro ATX Form Factor

The **microATX (MATX)** form factor is a major variation of ATX and addresses some technologies that have emerged since the original development of ATX. MicroATX reduces the total cost of a system by reducing the number of expansion slots on the motherboard, reducing the power supplied to the board, and allowing for a smaller case size. A microATX motherboard (see Figure 17) will fit into a case that follows the ATX 2.1 or higher standard. A microATX power supply uses a 24-pin P1 connector and is not likely to have as many extra wires and connectors as those on an ATX power supply.



Figure (17) This microATX motherboard by Biostar is designed to support an AMD processor  
Now let's learn about the drives you might find installed inside a system.



### 3- Drives, Their Cables, and Connectors

A computer might have one or more hard drives, an optical drive (CD, DVD, or Blu-ray), tape drive, or some other type of drive. A drive receives power by a power cable from the power supply, and communicates instructions and data through a cable attached to the motherboard. Most hard drives, optical drives, and tape drives today use the **serial ATA (SATA)** standard.

**Notes** If you support older desktop computers, you might see some drives using the slower and older PATA (parallel ATA) standard, also called the IDE (Integrated Drive Electronics) or EIDE (Enhanced IDE) standard, for drive connections. PATA used a 40-pin connector on the motherboard and a wide ribbon cable that could accommodate one or two drives on the cable. Figure 1-18 shows two PATA ribbon cables, each connecting a drive to the motherboard.

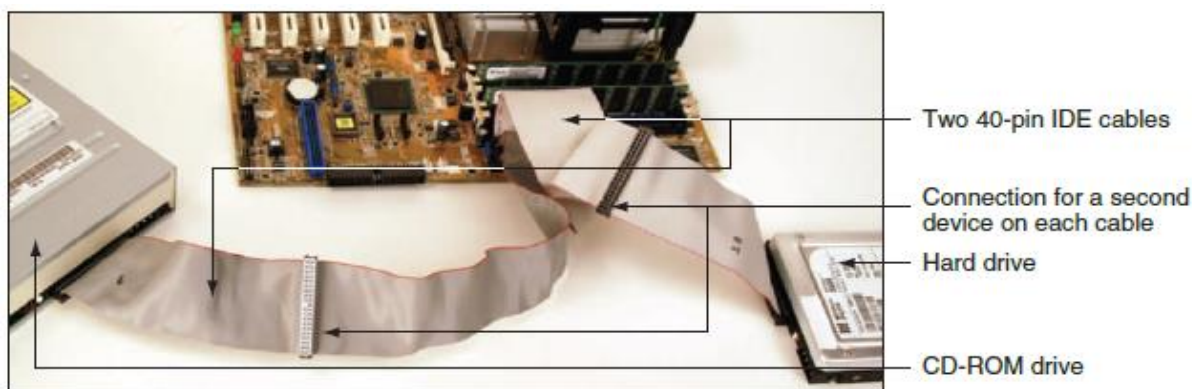


Figure (18) Two PATA devices connected to a motherboard using both PATA or IDE connections and two cables

SATA and PATA standards are published by the American National Standards Institute (ANSI). Figure (19) shows a SATA cable connecting a hard drive and motherboard. SATA drives get their power from a power cable that connects to the drive using a SATA power connector (refer back to the photo in Table 2).

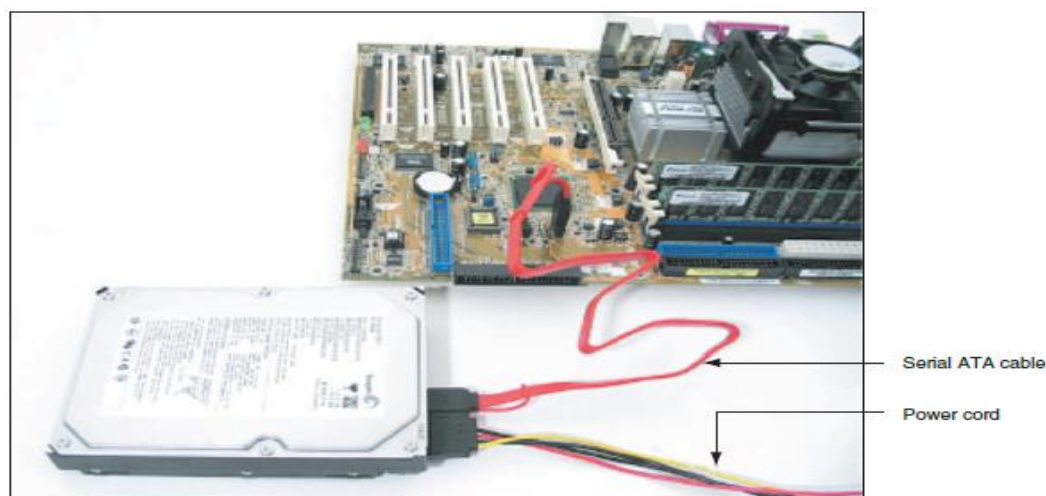


Figure (19) A hard drive subsystem using the SATA data cable

### LEACTURE SUMMARY

- Video ports a computer might have include the VGA, S-Video, DVI, DisplayPort, and HDMI ports. Other ports include RJ-45, audio, S/PDIF, USB, FireWire, eSATA, PS/2, serial, parallel, and RJ-11 ports. A Thunderbolt port can transmit video, data, and power.
- Internal computer components include the motherboard, processor, expansion cards, DIMM memory modules, hard drive, optical drive, and power supply.
- Form factors used by cases, power supplies, and motherboards are the ATX and microATX form factors. The form factor determines how the case, power supply, and motherboard fit together and the cable connectors and other standards used by each.
- Power connectors used by the ATX and microATX form factors include the 20-pin P1, 24-pin P1, 4-pin and 8-pin CPU auxiliary motherboard, 4-pin Molex, 15-pin SATA, 4-pin Berg, and 6/8-pin PCIe connectors.
- The two main types of expansion slots in a desktop computer are PCI and PCI Express (PCIe).
- Most hard drives, optical drives, and tape drives today use the serial ATA (SATA) standards for the drive to interface with the motherboard and power supply.